

MATHEMATICAL ANALYSIS II
INTEGRAL CALCULUS

SEVER ANGEL POPESCU

To my family.

.....

.....

To those who really try to put their lives in the Light of
Truth.

.....
Dedicated to the memory of my late Professor and
Mentor, Dr. Doc. Nicolae Popescu.

Contents

Preface	7
Chapter 1. Indefinite integrals (Primitives, Antiderivatives)	1
1. Definitions, some properties and basic formulas	1
2. Some results on polynomials	10
3. Primitives of rational functions	21
4. Primitives of irrational and trigonometric functions	27
5. Problems and exercises	47
Chapter 2. Definite integrals	49
1. The mass of a linear bar	49
2. Darboux sums and their applications	52
3. Lebesgue criterion and its applications	59
4. Mean theorem. Newton-Leibniz formula	63
5. The measure of a figure in \mathbb{R}^n	68
6. Areas of plane figures bounded by graphics of functions	75
7. The volume of a rotational solid	85
8. The length of a curve in \mathbb{R}^3	87
9. Approximate computation of definite integrals.	90
10. Problems and exercises	101
Chapter 3. Improper (generalized) integrals	105
1. More on limits of functions of one variable	105
2. Improper integrals of the first type	112
3. Improper integrals of the second type	122
4. Problems and exercises	135
Chapter 4. Integrals with parameters	137
1. Proper integrals with parameters	137
2. Improper integrals with parameters	147
3. Euler's functions gamma and beta	167
4. Problems and exercises	179
Chapter 5. Line integrals	181
1. The mass of a wire. Line integrals of the first type.	181
2. Line integrals of the second type.	194

3. Independence on path. Conservative fields	201
4. Computing plane areas with line integrals	211
5. Supplementary remarks on line integrals	216
6. Problems and exercises	221
Chapter 6. Double integrals	225
1. Double integrals on rectangles.	225
2. Double integrals on an arbitrary bounded domain	233
3. Green formula. Applications.	244
4. Change of variables in double integrals. Polar coordinates.	251
5. Problems and exercises	263
Chapter 7. Triple integrals	265
1. What is a triple integral on a parallelepiped?	265
2. Triple integrals on a general domain.	271
3. Iterative formulas for a general space domain	278
4. Change of variables in a triple integral	286
5. Problems and exercises	303
Chapter 8. Surface integrals	305
1. Deformation of a $2D$ -domain into a space surface	305
2. Surface integral of the first type. The mass of a $3D$ -lamina.	313
3. Flux of a vector field through an oriented surface.	319
4. Problems and exercises	335
Chapter 9. Gauss and Stokes formulas. Applications	339
1. Gauss formula (divergence theorem)	339
2. A mathematical model of the heat flow in a solid	348
3. Stokes Theorem	349
4. Problems and exercises	357
Chapter 10. Some remarks on complex functions integration	359
1. Complex functions integration	359
2. Applications of residues formula	377
3. Problems and exercises	385
Appendix A. Exam samples	387
1. June, 2010	387
2. June, 2010	387
3. June, 2010	387
4. June, 2010	388
5. September, 2010	388
6. September, 2010	388
Appendix B. Basic antiderivatives	389

CONTENTS

5

Appendix. Index

391

Appendix. Bibliography

397

Preface

Here is the second volume "Mathematical Analysis II. Integral Calculus" of my course of Advanced Calculus for Engineers and beginning Mathematicians. The first volume "Mathematical Analysis I. Differential Calculus" appeared in 2009 (see [Po]). I invite the reader to carefully meditate on the main ideas I discussed in the Preface of this first volume. The matter is about the way I think Mathematical Analysis (or Advanced Calculus) have to be taught to an engineering student. First of all I insist on a strong and correct intuitive basis of any mathematical notion and statement. Then I proceed step by step to a rigorously mathematical model of this notion or statement. My aim in this course (primarily intended for engineering students) is to create an intuitive thinking to the reader who must feel the simplicity and the naturalness of the introduced notion or concept. Abstract Mathematics need not destroy the intuition of the future engineer. Mathematical courses must make this intuition stronger, more mature and very solid. This is why this course appeared to be "a spoken course". I wanted it to be so! In general, I like a lot "live" Mathematics. A "dead" abstract notion, without at least one small motivation, generally will remain dead and nonuseful for an engineering student.

I also blame the opposite side, that mathematical teaching which consists only on a sequence of examples, motivations, etc., without a general definition, without a mathematical correct reasoning, based on "stories", etc. A creative middle way teaching is to be preferred. All of these belong to something which is beyond Mathematics itself, namely to the "Art of Teaching".

For instance, many times in this volume, the idea of the convergence of a system A of numbers to a number I , was substituted with the idea of a "well approximation" of I with numbers of A . Surely, I could use from the very beginning the definition "with ε " and everything could appeared formally rigorous for an "extremist" mathematician, but this course is not intended for such a people! If I had done so, I would have killed the intuitive power of the idea of approximation, extremely useful for a future engineer and not only for him!

In fact, in all my courses of Mathematical Analysis, I carried on the basic idea of Prof. Dr. Gavril Păltineanu to make appropriate mathematical courses for engineers and not for mathematicians. I think that even a student in abstract Mathematics could find a good opportunity to read such an "applicable" course.

This book contains ten chapters and an appendix with exam samples and a table with some basic formulas for primitives (antiderivatives). Since I successively introduced in the first volume ([Po]) basic elements of complex functions theory, I continued here with some basic remarks on integrals of functions with a complex variable, residues theory and some of their applications.

I started with a serious review of the calculus of primitives, usually assumed to be known from high school by the Romanian student.

I go on with definite or Riemann integrals, improper integrals, integrals with parameters, line integrals, double and triple integrals, surface integrals, Gauss and Stokes formulas and I finish with complex functions integrals.

Any chapter contains many motivation-examples, worked exercises and proposed exercises. I insisted on using instead of an abstract mathematical notion more intuitive objects taken from Physics, Mechanics, Strains of Materials, etc. Don't say that the word "deformation" is not better for an engineering student than the corresponding mathematical notion of "vector transformation", "parametric path", "parametric sheet", etc.

Many people contributed directly or indirectly to this volume.

The late Professor Dr. Doc. Nicolae Popescu, my Professor and my Master, was teaching me to do "live" Mathematics.

My colleague and my friend Prof. Dr. Gavriil Păltineanu challenged me to investigate the interesting way to teach Analysis for engineers. He gave me many deep advises on this fascinating domain which is Mathematical Analysis. He also carried this difficult task to read this huge volume and to push me in making many corrections.

Prof. Dr. Octav Olteanu and Prof. Dr. Nicolae Dăneț read carefully the entire manuscript and made some very useful suggestions.

I am also grateful to my younger colleagues Dr. Emil Popescu, Dr. Viorel Petrehuș, Dr. Marilena Jianu and Dr. Valentin Popescu for helping me a lot with the proofreading.

At last, but not the least, I will always express my thanks to two persons: to my wife Angela for encouraging me to "go on" with this difficult task and to my $1\frac{1}{2}$ years old grand-daughter Monica Izabela who succeeded to refresh a lot my tired mind before chapter 4. This

is why the reader must be grateful to her for the easy (but not short) way I succeeded to present the improper integrals with parameters.

Finally, I mention the special help that trees and birds of my close park gave me during my silent walk around the lake in those hot evenings of August 2010. All of these are of a great importance when one is thinking of mathematical affairs.

Prof. Dr. Sever Angel Popescu
Technical University of Civil Engineering Bucharest
Department of Mathematics and Computer Science
B=dul Lacul Tei 124, Sector 2, Bucharest, ROMANIA
angel.popescu@gmail.com
February, 2011

CHAPTER 1

Indefinite integrals (Primitives, Antiderivatives)

1. Definitions, some properties and basic formulas

We shall see later that in many problems coming from Geometry, Statistics, Mechanics, Physics, Chemistry, Engineering, Biology, Economy, etc. we have to compute the area of a plane figure bounded by the lines $x = a$, $x = b$, $y = 0$ and the graphic of a nonnegative continuous function $y = f(x)$, where $x \in [a, b]$, $a < b$ (see Fig.1).

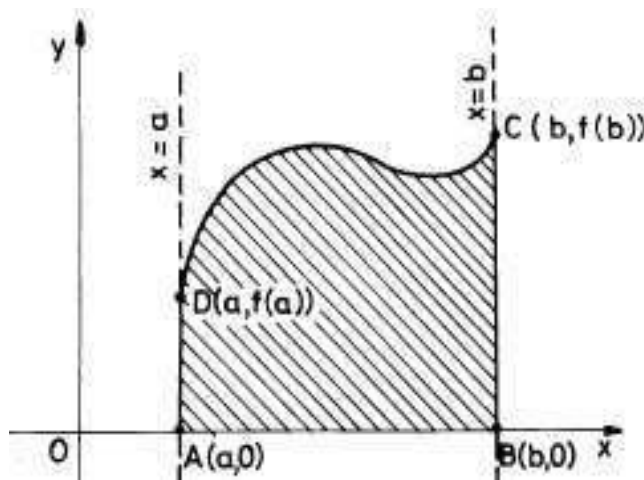

FIGURE 1.

Such a figure is usually called a *curvilinear trapezoid*. The great English scientist Sir Isaac Newton (1642-1727) discovered the mathematical relation between the function $y = f(x)$ and this area.

THEOREM 1. (*I. Newton*) Let $f : [a, b] \rightarrow \mathbb{R}_+$ be a continuous function defined on a real closed interval $[a, b]$ with nonnegative real values. Let x be a number in $(a, b]$ and let $F(x)$ be the area of the curvilinear trapezoid $[AxMD]$ (the area under the graphic of f "up to the point x " (see Fig.2). Then this area function is differentiable and its derivative $F'(x)$ at the point x is exactly $f(x)$, the value of the initial function f at the same point x .

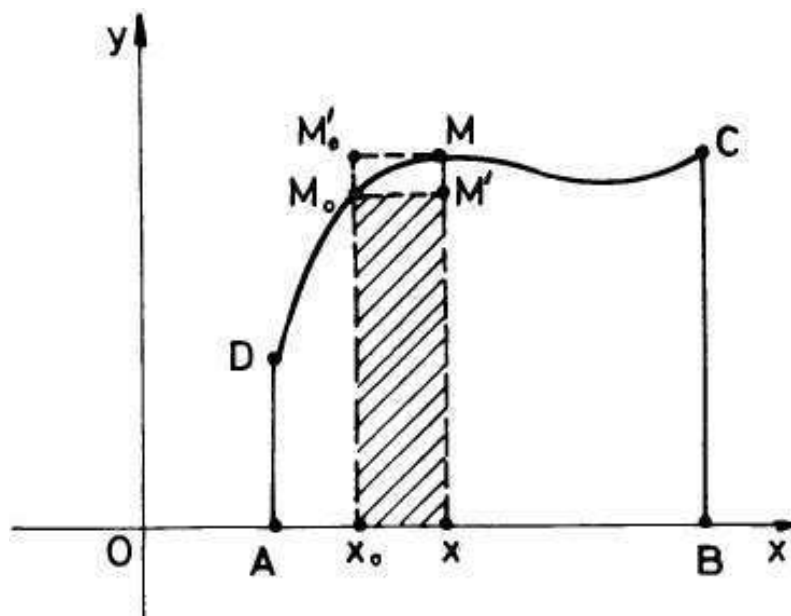

FIGURE 2.

PROOF. (intuitively proof; you will see later a mathematically rigorous proof) Let us fix a point x_0 in $(a, b]$. We are going to prove that the derivative $F'(x_0)$ exists and it is equal to $f(x_0)$. By definition

$$(1.1) \quad F'(x_0) = \lim_{x \rightarrow x_0} \frac{F(x) - F(x_0)}{x - x_0},$$

if this limit exists. Let us take for instance $x \in (a, b]$, $x > x_0$ (if $x_0 = b$, then take $x < x_0$ and do a completely similar reasoning!). But $F(x) - F(x_0)$ is exactly the area of the curvilinear trapezoid $[M_0x_0xM]$ (see also Fig.2). Since f is continuous, this area can be well approximated by the area of the rectangle $[M_0x_0xM']$. Indeed, in the case of our figure (Fig.2), the least value of f on the interval $[x_0, x]$ is realized at the point x_0 and the greatest is realized at the point x (use the boundedness Weierstrass theorem ([P0], Theorem 32), for a more general situation). So, the area of the curvilinear trapezoid $[M_0x_0xM]$ is a number between the area of the rectangle $[M_0x_0xM']$ and the area of the rectangle $[M'_0x_0xM]$. When M becomes closer and closer to M_0 , these last two areas tends to give the same number, so the area of the curvilinear trapezoid can be well approximated by the area of the rectangle $[M_0x_0xM']$. Thus, using now the corresponding mathematical expressions, we get:

$$(x - x_0)f(x_0) \leq F(x) - F(x_0) \leq (x - x_0)f(x),$$

or

$$(1.2) \quad f(x_0) \leq \frac{F(x) - F(x_0)}{(x - x_0)} \leq f(x).$$

Since f is continuous, taking limits when $x \rightarrow x_0$ in (1.2), we get that $F'(x_0)$ exists and that it is equal to $f(x_0)$. \square

The area function constructed above is called the *Newton area function* of f .

COROLLARY 1. *Let $f : [a, c) \rightarrow \mathbb{R}$ be a continuous function which does not change its sign on the interval $[a, c)$ (here c may be even $\infty!$). Then, there is a differentiable function F defined on this interval (a, c) such that $F'(x) = f(x)$ for any $x \in (a, c)$.*

PROOF. It is sufficient to take f to be nonnegative (otherwise replace f by $-f$). Then we define like above $F(x) =$ the area of the curvilinear trapezoid $[AxMD]$ (see Fig.2). \square

EXERCISE 1. *Try to substitute the above interval $[a, c)$ for an open finite or infinite interval (a, c) . Moreover, try to substitute this last interval for any open subset of \mathbb{R} .*

All of the discussion above is a real motivation for the following general definition.

DEFINITION 1. *Let A be an open subset of the real line \mathbb{R} . Let $f : A \rightarrow \mathbb{R}$ be a function defined on A with values in \mathbb{R} . Any differentiable function $F : A \rightarrow \mathbb{R}$ such that its derivative $F'(x)$ is equal to $f(x)$ for any x in A (simply if $F' = f$) is called a *primitive* of f on A . It is also called an *antiderivative* or an *integral* of f on A .*

In the following all functions are defined only on subsets A of \mathbb{R} , which have no isolated points. We shall simply note A for a subset satisfying this last property. We introduced this restriction because it is a nonsense to speak about the limit of a function at an isolated point. In particular, about its derivative!

If we remember the definition of the notion of a differential $dF(a)$ of a function F at a point a of A , namely $dF(a)$ which is the linear mapping defined on \mathbb{R} with values in the same \mathbb{R} , such that $dF(a)(h) = F'(a)h$ for any h in \mathbb{R} , or $dF(a) = F'(a)dx$, where dx is the differential of the variable x (in our case the identity mapping-see Analysis I, [Po]), we can easily prove the following very useful result.

THEOREM 2. *Let $f : A \rightarrow \mathbb{R}$ be a function defined on A (as above). A function $F : A \rightarrow \mathbb{R}$ is a primitive of f on A if and only if it is*

differentiable on A and $dF = f dx$, i.e. its differential $dF(a)$ at any point a of A is equal to $f(a)dx$.

A primitive F of f is denoted by the notation $\int f(x)dx$ and it is also called an *integral of f with respect to the variable x* . Moreover, an expression of the form $f dx$ is called a *differential form* of order one in one variable x . A *primitive* of such a differential form is a function $U : A \rightarrow \mathbb{R}$ such that U is differentiable on A and $dU = f dx$, equivalently $U'(x) = f(x)$ for any x in A . Now, the notation $\int f(x)dx$ means such a primitive U for the differential form $f dx$. It is useful for us in the following to speak the primitives of differential forms language, instead of using the language of primitives for usual functions.

To decide if a differential form has a primitive or not is in general a very difficult problem. We shall prove later a more general result than that one of exercise 1. Namely, one can rigorously prove (see Chapter 2) that any continuous function f on an interval I has a primitive F on I . This means that for a continuous function f on an interval I , the differential form $f dx$ has a primitive F , i.e. $dF = f dx$.

For instance, a primitive of $f(x) = \cos x$ is $F(x) = \sin x$ because $d(\sin x) = \cos x dx$. We see that a function of the form $\sin x + C$, where C is an arbitrary constant (does not depend on x . It may depend on any other variable distinct of x), is also a primitive of $\cos x$. Indeed,

$$d(\sin x + C) = d(\sin x) + dC = \cos x dx + 0 = \cos x dx.$$

So, if a function f has a primitive F on an open subset A of \mathbb{R} , then it has an infinite number of primitives, namely, any function of the form: $F + C$, where C is a constant w.r.t. x (prove this as in the case of $f(x) = \cos x$).

THEOREM 3. *(a structure theorem for all primitives) Let $f : I \rightarrow \mathbb{R}$ be a function defined on an interval I and let F be a fixed primitive of it (on I). Then any other primitive G of f on the interval I is of the form $G = F + C$, where C is a constant number (which depends only on G). This is why the set of all primitives of f is denoted by $\int f(x)dx + C$. Here $\int f(x)dx$ means any fixed primitive of f on I .*

PROOF. Since $F'(x) = f(x) = G'(x)$ for any x in I , one can see that the difference function $H = G - F$ has its derivative equal to zero at any point of I . We are going to prove that in this case H must be a constant, i.e. it cannot depend on the variable x . This means that for any points a and b of I we must have that $H(a) = H(b)$. Indeed, let us suppose that $a < b$ and let us apply Lagrange theorem on the closed interval $[a, b]$ (which is included in I , why?):

$$H(b) - H(a) = H'(c)(b - a),$$

for a point c in (a, b) . Since $H'(x) = 0$ for any x of I , one gets that $H(b) = H(a)$. Let us denote by C this common value of $H(x)$. Hence, $G - F = C$, or $G = F + C$. This means that for this fixed number C , we have that $G(x) = F(x) + C$ for any $x \in I$. \square

REMARK 1. *If the set A is not an interval, then the above result is not always true. For instance, let $A = (0, 1) \cup (2, 3)$ and $f(x) = 2x$ for any x of A . It is easy to see that the following two functions*

$$F(x) = \begin{cases} x^2, & \text{for } x \in (0, 1) \\ x^2 + 1, & \text{for } x \in (2, 3) \end{cases},$$

$$G(x) = \begin{cases} x^2, & \text{for } x \in (0, 1) \\ x^2, & \text{for } x \in (2, 3) \end{cases}$$

are primitives of f . It is clear enough that there is no constant number C such that $G(x) = F(x) + C$ for any x in A . Indeed, for $x \in (0, 1)$, $C = 0$ and for $x \in (2, 3)$, $C = -1$, so we cannot have the same constant C on the entire set A .

EXAMPLE 1. *Let us find a primitive for the following continuous function*

$$f(x) = \begin{cases} x, & \text{if } x \in [-1, 1] \\ x^3, & \text{if } x \in (1, 2) \\ x^2 + 4, & \text{if } x \in [2, 3] \end{cases},$$

$f : [-1, 3] \rightarrow \mathbb{R}$. Since $\left(\frac{x^2}{2}\right)' = x$, $\left(\frac{x^4}{4}\right)' = x^3$ and $\left(\frac{x^3}{3} + 4x\right)' = x^2 + 4$, any primitive of f is of the following form:

$$F(x) = \begin{cases} \frac{x^2}{2} + C_1, & \text{if } x \in [-1, 1] \\ \frac{x^4}{4} + C_2, & \text{if } x \in (1, 2) \\ \frac{x^3}{3} + 4x + C_3, & \text{if } x \in [2, 3] \end{cases},$$

Let us force now F to be continuous at $x = 1$ (F is differentiable, thus it must be continuous):

$$\frac{1}{2} + C_1 = \frac{1}{4} + C_2,$$

so we get that $C_2 = \frac{1}{4} + C_1$. The continuity of F at $x = 2$ implies that

$$\frac{2^4}{4} + \frac{1}{4} + C_1 = \frac{2^3}{3} + 8 + C_3,$$

thus $C_3 = -\frac{77}{12} + C_1$. Hence, all the primitives of f are:

$$F(x) = \begin{cases} \frac{x^2}{2}, & \text{if } x \in [-1, 1] \\ \frac{x^4}{4} + \frac{1}{4}, & \text{if } x \in (1, 2) \\ \frac{x^3}{3} + 4x - \frac{77}{12}, & \text{if } x \in [2, 3] \end{cases} + C_1,$$

where C_1 is an arbitrary constant (with respect to x) number. It is easy to see that $F(x)$ is differentiable and $F'(x) = f(x)$ for any $x \in [-1, 3)$.

EXAMPLE 2. Here is an example of a discontinuous function which has no primitive at all. Let

$$f(x) = \begin{cases} 1, & \text{for } x \in [0, 1] \\ 0, & \text{for } x \in (1, 2] \end{cases}.$$

It is easy to see that a primitive of f must be of the form:

$$F(x) = \begin{cases} x + C_1, & \text{for } x \in [0, 1] \\ C_2, & \text{for } x \in (1, 2] \end{cases}.$$

The continuity of F at $x = 1$ implies that $C_2 = 1 + C_1$, thus,

$$F(x) = \begin{cases} x + C_1, & \text{for } x \in [0, 1] \\ 1 + C_1, & \text{for } x \in (1, 2] \end{cases}.$$

But this last function is not differentiable at $x = 1$ for no value of C_1 (why?). Hence, F cannot be a primitive of f on $[0, 2]$!

But, do not you hurry to conclude that all the discontinuous functions have no primitive. Here is a counterexample!

EXAMPLE 3. The function

$$f(x) = \begin{cases} 2x \sin \frac{1}{x} - \cos \frac{1}{x}, & \text{for } x \in (0, 1] \\ 0, & \text{for } x = 0 \end{cases},$$

$f : [0, 1] \rightarrow \mathbb{R}$. Since $\lim_{x \rightarrow 0} 2x \sin \frac{1}{x} = 0$ (prove it!) and since $\lim_{x \rightarrow 0} \cos \frac{1}{x}$ does not exist ($x_n = \frac{1}{2n\pi}$ and $x'_n = \frac{2}{(4n+1)\pi}$ are convergent to 0, but $\cos \frac{1}{x_n} = 1 \rightarrow 1$ and $\cos \frac{1}{x'_n} = 0 \rightarrow 0$), we see that function f has no limit at $x = 0$. In particular, it is not continuous at $x = 0$. At the same time, it is easy to prove that the function

$$F(x) = \begin{cases} x^2 \sin \frac{1}{x}, & \text{for } x \in (0, 1] \\ 0, & \text{for } x = 0 \end{cases}$$

is a primitive for f on $[0, 1]$.

In general, to decide if a given noncontinuous function has a primitive or not is a difficult task.

The main problem which is to be considered in the following is the one of the effective construction of primitives for some classes of continuous functions.

Here is a table with the primitives of the basic elementary functions, mostly used in Mathematics and in its applications. We write down only one primitive (the immediate one, obtained by a direct process of

anti-differentiation). The others can be obtained by adding a constant number to this last one.

$$(1.3) \quad \int x^\alpha dx = \frac{x^{\alpha+1}}{\alpha+1}, \text{ if } \alpha \neq -1, (x > 0, \text{ if } \alpha \text{ is not an integer})$$

$$(1.4) \quad \int \frac{1}{x} dx = \ln x, \text{ if } x \in I,$$

where I is any interval contained in $(0, \infty)$.

$$(1.5) \quad \int \frac{1}{x} dx = \ln(-x), \text{ if } x \in J,$$

where J is any interval contained in $(-\infty, 0)$.

$$(1.6) \quad \int e^x dx = e^x$$

$$(1.7) \quad \int a^x dx = \frac{a^x}{\ln a}, \text{ if } a > 0 \text{ and } a \neq 1.$$

$$(1.8a) \quad \int \frac{1}{x^2+1} dx = \arctan x$$

$$(1.9) \quad \int \frac{1}{x^2+a^2} dx = \frac{1}{a} \arctan \frac{x}{a}, \text{ if } a \neq 0.$$

$$(1.10) \quad \int \sin x dx = -\cos x$$

$$(1.11) \quad \int \cos x dx = \sin x$$

$$(1.12) \quad \int \frac{1}{\sqrt{1-x^2}} dx = \arcsin x, \text{ if } x \in (-1, 1).$$

$$(1.13) \quad \int \frac{1}{\sqrt{a^2-x^2}} dx = \arcsin \frac{x}{a}, \text{ if } x \in (-a, a).$$

$$(1.14) \quad \int \frac{1}{\sqrt{x^2+\alpha}} dx = \ln(x + \sqrt{x^2+\alpha}),$$

if $\alpha \neq 0, x^2 + \alpha > 0$ and $x + \sqrt{x^2 + \alpha} > 0$.

$$(1.15) \quad \int \frac{1}{\cos^2 x} dx = \tan x,$$

if x belongs to any interval which does not contain any number of the form $n\pi + \frac{\pi}{2}$, $n \in \mathbb{Z}$.

$$(1.16) \quad \int \frac{1}{\sin^2 x} dx = -\cot x,$$

if x belongs to any interval which does not contain any number of the form $n\pi$, $n \in \mathbb{Z}$.

$$(1.17) \quad \int \sinh x dx = \cosh x, \quad \int \cosh x dx = \sinh x,$$

where $\sinh x = \frac{e^x - e^{-x}}{2}$ and $\cosh x = \frac{e^x + e^{-x}}{2}$.

All of the above formulas can be directly verified by differentiating the function from the right side of each equality. Let's verify for instance formula (1.14):

$$\left(\ln(x + \sqrt{x^2 + \alpha}) \right)' = \frac{1}{x + \sqrt{x^2 + \alpha}} \left(1 + \frac{2x}{2\sqrt{x^2 + \alpha}} \right) = \frac{1}{\sqrt{x^2 + \alpha}}.$$

THEOREM 4. (*linearity*) Let $f, g : I \rightarrow \mathbb{R}$ be two functions defined on the same interval I and let α, β be two real numbers. Let $\int f(x)dx$ and $\int g(x)dx$ be two primitives of f and g respectively (on I). Then $\alpha \int f(x)dx + \beta \int g(x)dx$ is a primitive of $\alpha f + \beta g$ on I .

PROOF. Since $(\int f(x)dx)' = f$ and $(\int g(x)dx)' = g$ (use only the definition!), we get that

$$\begin{aligned} & \left(\alpha \int f(x)dx + \beta \int g(x)dx \right)' = \\ & = \alpha \left(\int f(x)dx \right)' + \beta \left(\int g(x)dx \right)' = \alpha f + \beta g \end{aligned}$$

and the proof is complete (why?). Here we used the linearity of the differential operator $h \rightarrow h'$. \square

This last result says that the "mapping" $f \rightarrow \int f(x)dx$ is linear. Here is a concrete example of the way we can work with this last property and with the above basic formulas.

EXAMPLE 4. Let us compute $\int \left(x^5 - 3x + 2\sqrt[3]{x} - \frac{7}{\sqrt[5]{x^3}} \right) dx$. The linearity of the integral operator \int (see theorem 4) and formula (1.3) imply that

$$\int \left(x^5 - 3x + 2\sqrt[3]{x} - \frac{7}{\sqrt[5]{x^3}} \right) dx = \int x^5 dx - 3 \int x dx +$$

$$\begin{aligned}
+2 \int x^{\frac{1}{3}} dx - 7 \int x^{-\frac{3}{5}} dx &= \frac{x^6}{6} - 3 \frac{x^2}{2} + 2 \frac{x^{\frac{4}{3}}}{\frac{4}{3}} - 7 \frac{x^{\frac{2}{5}}}{\frac{2}{5}} = \\
&= \frac{x^6}{6} - \frac{3}{2} x^2 + \frac{3}{2} x^{\frac{4}{3}} - \frac{35}{2} x^{\frac{2}{5}}.
\end{aligned}$$

Let J be another interval and let $u : J \rightarrow I$, $x = u(t)$, be a function of class $C^1(J)$. Then $dx = u'(t)dt$ (see Analysis I, [Po]). Let $f : I \rightarrow \mathbb{R}$ be a continuous function of the variable $x \in I$. Let $F(x)$ be a primitive of f on I . Then $F(u(t))$ is a primitive of the function $f(u(t))u'(t)$ of t , i.e.

$$(1.18) \quad \int f(u(t))d(u(t)) = \left(\int f(x)dx \right) (u(t)).$$

Indeed,

$$[F(u(t))] = F'(u(t))u'(t) = f(u(t))u'(t).$$

Formula (1.18) is called the *change of variable formula for integral computation*. This formula says that if in an integral $\int h(x)dx$ one can put in evidence an expression $u = u(x)$ such that $h(x)dx = f(u(x))du$ and if one can compute $\int f(u)du$ then, put instead of u , $u(x)$ in this last primitive and we obtain a primitive $\int h(x)dx$ for the differential form hdx .

EXAMPLE 5. Let us compute $\int \frac{1}{3x+2} dx$, where $3x + 2 < 0$. If we denote $u = 3x + 2$ then, $du = 3dx$ (why?). Thus, our integral becomes $\frac{1}{3} \int \frac{1}{3x+2} d(3x+2)$. Since $u = 3x+2 < 0$, a primitive for $\int \frac{1}{u} du$ is $\ln(-u)$ (see formula (1.5)). So, a primitive of $\frac{1}{3x+2} dx$ is $\frac{1}{3} \ln(-3x - 2)$.

Sometimes it is easier to directly compute dx as a function of t and dt . For instance, let us compute $\int \tan^3 x dx$. Let us change the variable: $t = \tan x$, $x \in (-\frac{\pi}{2}, \frac{\pi}{2})$ (why this restriction?). Since

$$dt = \frac{1}{\cos^2 x} dx = (1 + \tan^2 x) dx = (1 + t^2) dx,$$

we get that

$$\begin{aligned}
\int \tan^3 x dx &= \int \frac{t^3}{1+t^2} dt = \int \frac{t^3 + t - t}{t^2 + 1} dt = \int t dt - \int \frac{t dt}{t^2 + 1} = \\
&= \frac{t^2}{2} - \frac{1}{2} \int \frac{d(t^2 + 1)}{t^2 + 1} = \frac{t^2}{2} - \frac{1}{2} \ln(t^2 + 1) = \\
&= \frac{1}{2} [\tan^2 x - \ln(\tan^2 x + 1)].
\end{aligned}$$

Let $f, g : I \rightarrow \mathbb{R}$ be two functions of class $C^1(I)$, where I is a real interval. We know the "*product formula*" :

$$(fg)' = f'g + fg'.$$

Applying the integral operator to both sides, we get:

$$(1.19) \quad \int f(x)g'(x)dx = fg - \int f'(x)g(x)dx.$$

or, in language of differentials,

$$(1.20) \quad \int fdg = fg - \int gdf$$

These last two formulas are called the *integral by parts formulas*. When do we use them? If one has to compute the integral $\int h(x)dx$ and if we can write $h(x) = f(x)g'(x)$ and if the integral $\int f'(x)g(x)dx$ can be easier computed, then formula (1.19) works. For instance, if we differentiate the function $f(x) = \ln x$, we get $\frac{1}{x}$ which is an "easier" function from the point of view of integral calculus. Practically, let us use this philosophy to compute the integral: $I_n = \int x^n \ln x dx$, where n is a natural number. For $n = 0$ we get

$$I_0 = \int \ln x dx = \int (\ln x)(x)' dx.$$

In formula (1.19) one can put $f(x) = \ln x$ and $g(x) = x$. Thus,

$$I_0 = x \ln x - \int \frac{1}{x} \cdot x dx = x \ln x - x.$$

Let us use the same "trick" for computing $I_n, n > 0$.

$$\begin{aligned} I_n &= \int x^n \ln x dx = \int (\ln x) \left(\frac{x^{n+1}}{n+1} \right)' dx = \frac{x^{n+1}}{n+1} \ln x - \int \frac{1}{x} \frac{x^{n+1}}{n+1} dx = \\ &= \frac{x^{n+1}}{n+1} \ln x - \frac{1}{n+1} \int x^n dx = \frac{x^{n+1}}{n+1} \ln x - \frac{x^{n+1}}{(n+1)^2}. \end{aligned}$$

2. Some results on polynomials

We begin with some facts on polynomial functions.

A *polynomial function* (or simply a *polynomial*) is a function P of one variable x , defined on \mathbb{R} by the following formula

$$P(x) = a_0 + a_1x + a_2x^2 + \dots + a_nx^n, \quad x \in \mathbb{R},$$

where a_0, \dots, a_n are fixed real numbers. These numbers are said to be the *coefficients* of P . We shortly write that $P(x)$, or $P \in \mathbb{R}[x]$, where $\mathbb{R}[x]$ is the set (a ring!) of all polynomials with real coefficients. For

instance, $P(x) = 2x - 1$ is a polynomial. Here $n = 1$, $a_0 = -1$ and $a_1 = 2$. If $a_n \neq 0$ (except the case $P = 0$ — this means that ALL its coefficients are zero, we always assume that the dominant coefficient a_n is not zero) we say that the degree of P is n and write this as $\deg P = n$. If $P(x) = a_0 \neq 0$, a nonzero constant, then $\deg P = 0$. If $P(x) = 0$ for any x (this is equivalent to saying that all its coefficients are zero), then the degree of P is by definition $-\infty$. This value was chosen to preserve the formula $\deg PQ = \deg P + \deg Q$ for $P = 0$ and $Q \neq 0$.

If $a_n = 1$ we say that the polynomial P is *monic*. For instance, $P(x) = x - 1$ is monic, but $Q(x) = -x - 1$ is not monic. If P has the degree greater or equal to 1 and if it cannot be written as a product of two polynomials of degrees greater or equal to 1, it is said to be *irreducible*. For instance, $P(x) = x^2 + 2$, $P(x) = 2x - 1$ are irreducible, but $Q(x) = x^2 - 1$ or $Q(x) = x^3$ are reducible, i.e. they can be decomposed into at least two factors of degrees greater than zero.

The following result is fundamental in Algebra.

THEOREM 5. (*Euclid's division algorithm*) *Let P and $Q \neq 0$ be two polynomials. Then there are another two polynomials C and R such that $P = CQ + R$ and $\deg R < \deg Q$. Here the polynomials C and R are uniquely defined by P and Q .*

PROOF. An "abstract" general proof can be found in [Lal]. But,... nothing is "abstract" here! We simply use the "division algorithm" for polynomials, which is very known even from elementary school Algebra. If $\deg P < \deg Q$, then take $C = 0$ and $R = P$. Assume that $n = \deg P \geq m = \deg Q$. We use mathematical induction with respect to n . If $n = 0$, then $m = 0$ ($Q \neq 0$) and $P = k$, $Q = h$, where k and h are two real numbers and $h \neq 0$ (why?). Since

$$k = \frac{k}{h}h + 0,$$

one can take $C = \frac{k}{h}$ and $R = 0$ ($\deg R = -\infty < \deg Q = 0$). Let now n be greater than 0 and let us assume that we have just proved the theorem for any $k = 0, 1, \dots, n - 1$. Let us prove it for $k = n$. Suppose $P(x) = a_n x^n + a_{n-1} x^{n-1} + \dots + a_0$ and $Q(x) = b_m x^m + b_{m-1} x^{m-1} + \dots + b_0$, where $a_n \neq 0$ and $b_m \neq 0$. Then, it is easy to see that

$$(2.1) \quad P(x) = Q \cdot \frac{a_n}{b_m} x^{n-m} + P_1(x),$$

where

$$P_1(x) = \left(a_{n-1} - \frac{a_n b_{m-1}}{b_m} \right) x^{n-1} + \dots + \left(a_{n-m} - \frac{a_n b_0}{b_m} \right) x^{n-m} +$$

$$+a_{n-m-1}x^{n-m-1} + \dots + a_0$$

is a polynomial of degree at most $n - 1$. Let us use now the induction hypothesis and write

$$P_1(x) = C_1Q + R,$$

where C_1 and R are polynomials, $\deg R < \deg Q$. Let us come back to formula (2.1) with this expression of $P_1(x)$ and find

$$P(x) = \left(\frac{a_n}{b_m}x^{n-m} + C_1 \right) Q + R.$$

If we put now $C = \frac{a_n}{b_m}x^{n-m} + C_1$, we just obtained the statement of the theorem for n . Hence the proof of the theorem is complete.

The uniqueness can be derived as follows. Let $P = DQ + S$, where $\deg S < \deg Q$. Then, $R - S = (D - C)Q$. If $R \neq S$, then the inequality, $\deg(R - S) = \deg(D - C)Q \geq \deg Q$, give rise to a contradiction (why?). Thus, $R = S$ and so $(D - C)Q = 0$ implies $D = C$ ($Q \neq 0$). \square

COROLLARY 2. *(the P-expansion of Q) Let P be a nonconstant polynomial and let Q be another arbitrary polynomial. Then Q can be uniquely written as*

$$(2.2) \quad Q = A_0 + A_1P + \dots + A_nP^n,$$

where A_0, A_1, \dots, A_n are polynomials of degrees at most $\deg P - 1$. We say that "we write Q in base P ". In particular, for any nonzero natural number m , one get:

$$(2.3) \quad \frac{Q}{P^m} = \frac{A_0}{P^m} + \frac{A_1}{P^{m-1}} + \dots + \frac{A_n}{P^{m-n}},$$

if $m > n$ and

$$(2.4) \quad \frac{Q}{P^m} = \frac{A_0}{P^m} + \frac{A_1}{P^{m-1}} + \dots + \frac{A_{m-1}}{P} + S,$$

where S is a polynomial, if $n \geq m$.

PROOF. We apply again mathematical induction on the degree of Q . If Q is a nonzero constant (degree zero) polynomial, then $Q = Q$ ($A_0 = Q$). Assume that $\deg Q > 0$ and that the statement is true for any polynomial Q_1 of degree $< \deg Q$. Let us apply Euclid's division algorithm for Q and P :

$$(2.5) \quad Q = CP + A_0,$$

where $\deg A_0 < \deg P$. Since $\deg C$ is less than $\deg Q$ ($\deg P > 0$), using the induction hypothesis, we get $C = A_1 + A_2P + \dots + A_nP^{n-1}$, where $\deg A_j < \deg P$, $j = 1, 2, \dots, n$. Coming back to formula (2.5) with this expression of C , we obtain exactly formula (2.2). \square

Let us apply this theory to the polynomials $Q(x) = x^3 + 2$ and $P(x) = x - 1$. Since

$$x^3 + 2 = C(x)(x - 1) + R,$$

putting $x = 1$ we get $R = 3$. Thus,

$$x^3 - 1 = C(x)(x - 1).$$

Hence, $C(x) = x^2 + x + 1$. Now,

$$x^2 + x + 1 = C_1(x)(x - 1) + R_1.$$

Making $x = 1$, we get $R_1 = 3$. So,

$$x^2 + x + 1 - 3 = x^2 + x - 2 = C_1(x)(x - 1).$$

Thus,

$$C_1(x) = x + 2 = 1 \cdot (x - 1) + 3.$$

Coming back, step by step, we obtain

$$\begin{aligned} x^3 + 2 &= 3 + (x - 1)[\{3 + 1 \cdot (x - 1)\}(x - 1) + 3] = \\ &= 3 + 3(x - 1) + 3(x - 1)^2 + (x - 1)^3. \end{aligned}$$

Let $\mathbb{C} = \{a + bi : a, b \in \mathbb{R}\}$, $i = \sqrt{-1}$, be the field of complex numbers. A fundamental result in Algebra (C. F. Gauss) [**La1**] says that the roots of any polynomial $P \in \mathbb{R}[x]$ are complex numbers, namely elements of the form $a + bi$, with a, b real numbers (see also theorem 100 in this book).

THEOREM 6. (*Bezout's theorem*) *Let $P = P(x)$ be a nonconstant polynomial and let $\alpha \in \mathbb{C}$ be a root of P ($P(\alpha) = 0$). Then $P(x) = A(x - \alpha)Q(x)$, where A is a constant number and $Q(x)$ is a monic polynomial. Moreover, if $\alpha_1, \dots, \alpha_s$ are all the distinct roots of P , then*

$$(2.6) \quad P(x) = A(x - \alpha_1)^{n_1}(x - \alpha_2)^{n_2} \dots (x - \alpha_s)^{n_s},$$

where A is the dominant coefficient of P ($A = a_n$) and n_1, \dots, n_s are the algebraic multiplicities of the roots $\alpha_1, \dots, \alpha_s$. All of these numbers are uniquely determined only by P .

PROOF. Let $P(x) = a_0 + a_1x + a_2x^2 + \dots + a_nx^n$, be our polynomial and let $A = a_n$. Then

$$(2.7) \quad P(x) = AT(x)$$

where $T(x)$ is the monic polynomial $x^n + \frac{a_{n-1}}{a_n}x^{n-1} + \dots + \frac{a_0}{a_n}$. Let us use Euclid's division algorithm for dividing $T(x)$ by $x - \alpha$:

$$(2.8) \quad T(x) = (x - \alpha)Q(x) + R,$$

where $Q(x)$ is a polynomial and R is a constant number. Since $T(\alpha) = 0$ (why?), making $x = \alpha$ in (2.8) one gets $R = 0$. Thus, $T(x) = (x - \alpha)Q(x)$ and, coming back to formula (2.7), we finally obtain that

$$P(x) = A(x - \alpha)Q(x).$$

Now we apply the same procedure to the monic polynomial $Q(x)$ and another root β of it:

$$P(x) = A(x - \alpha)(x - \beta)Q_1(x),$$

where Q_1 is a polynomial with $\deg P > \deg Q > \deg Q_1$. We continue in this way and finally obtain

$$P(x) = A(x - \alpha)(x - \beta)\dots(x - \omega),$$

where $\alpha, \beta, \dots, \omega$ are all the n roots of P . Let us put together the equal roots and so we get the required expression (2.6). \square

A bijection $\sigma : \mathbb{C} \rightarrow \mathbb{C}$ which is a field morphism, i.e.

$$(2.9) \quad \sigma(z + w) = \sigma(z) + \sigma(w), \sigma(zw) = \sigma(z)\sigma(w)$$

is called an *automorphism* of \mathbb{C} . An \mathbb{R} -automorphism μ of \mathbb{C} is an automorphism of \mathbb{C} which does not change the elements of \mathbb{R} , i.e. $\mu(a + 0i) = a$, if $a \in \mathbb{R}$. For instance, it is easy to see (prove it!) that the identity $e : \mathbb{C} \rightarrow \mathbb{C}$, $e(z) = z$ and the *conjugation* $\bar{e} : \mathbb{C} \rightarrow \mathbb{C}$, $\bar{e}(a + bi) = a - bi$ are \mathbb{R} -automorphisms of \mathbb{C} . We also denote $\bar{e}(z)$ by \bar{z} , the conjugate of z . For instance, $\overline{3 - 4i} = 3 + 4i$ and $\overline{3.5} = 3.5$.

LEMMA 1. *Let*

$$P(x) = a_0 + a_1x + a_2x^2 + \dots + a_nx^n$$

be a polynomial with real coefficients and let $\alpha \in \mathbb{C}$ be a root of it, i.e.

$$P(\alpha) = a_0 + a_1\alpha + a_2\alpha^2 + \dots + a_n\alpha^n = 0.$$

Let σ be a \mathbb{R} -automorphism of \mathbb{C} . Then, the complex number $\sigma(\alpha)$ is also a root of the polynomial P .

PROOF. Let us apply σ to the equality

$$a_0 + a_1\alpha + a_2\alpha^2 + \dots + a_n\alpha^n = 0.$$

Taking into account the algebraic properties (2.9) of σ and the fact that it preserves the real coefficients a_0, \dots, a_n , we get

$$a_0 + a_1\sigma(\alpha) + a_2\sigma(\alpha)^2 + \dots + a_n\sigma(\alpha)^n = 0,$$

i.e. the complex number $\sigma(\alpha)$ verifies the equality: $P(x) = 0$, thus $\sigma(\alpha)$ is another root of P . \square

This lemma says that any \mathbb{R} -automorphism σ of \mathbb{C} permutes the roots between them. For instance, since i is a root of the equation $X^2 + 1 = 0$, $\sigma(i) = i$ or $\sigma(i) = -i$. If $\sigma(i) = i$, $\sigma(a + bi) = a + bi$, i.e. $\sigma = e$, the identity. If $\sigma(i) = -i$, then $\sigma(a + bi) = a - bi$, i.e. $\sigma = \bar{e}$, the conjugation automorphism of \mathbb{C} . These considerations lead us directly to the following basic result.

THEOREM 7. *Any monic irreducible polynomial P with real coefficients is either of the form $P(x) = x - a$, or of the form $P(x) = x^2 + bx + c$, where a, b, c are real numbers.*

PROOF. If our polynomial P is of degree 1 everything is clear. If $\deg P > 1$, let α be one of its root in \mathbb{C} . Use lemma 1 and find that its conjugate $\bar{\alpha}$ is also a root of $P(x)$. If $\bar{\alpha} = \alpha$, i.e. if α is a real number, then $P(x)$ is divisible by the polynomial $Q(x) = x - \alpha$ (see theorem 6). Since $\deg P > 1$ and since $Q(x)$ is a factor of $P(x)$, we obtain a contradiction (P was considered to be irreducible). Hence, the root α is not real. Let us denote $b = -(\alpha + \bar{\alpha})$ and $c = \alpha\bar{\alpha}$. Since $\overline{\alpha + \bar{\alpha}} = \bar{\alpha} + \alpha$ and $\overline{\alpha\bar{\alpha}} = \bar{\alpha}\alpha$ we see that $b, c \in \mathbb{R}$. The polynomial $H(x) = (x - \alpha)(x - \bar{\alpha}) = x^2 + bx + c$ is a divisor of P . Indeed, let us divide P by H . Thus, $P = HU + V$, where $\deg V < 2$. Moreover, $V(\alpha) = 0$ and $V(\bar{\alpha}) = 0$, i.e. V is a polynomial of degree at most 1 which has two distinct roots! The only possibility is that V be identically with zero, so $P = HU$. Since P is irreducible, U must be a constant polynomial and, since P and H are both monic, this last constant polynomial must be 1. Thus,

$$P = H = x^2 + bx + c.$$

□

The following theorem (see [La1] for instance) is a basic result in Algebra.

THEOREM 8. *(factorial theorem). Let P be a nonconstant polynomial with real coefficients. Then P can be uniquely written as*

$$(2.10) \quad P = AP_1^{n_1}P_2^{n_2}\dots P_k^{n_k},$$

where A is a constant number and P_1, P_2, \dots, P_k are distinct monic irreducible polynomials of degrees 1 or 2. "Uniquely" here means that if

$$P = BQ_1^{m_1}Q_2^{m_2}\dots Q_h^{m_h},$$

is a decomposition of P of the same type (B constant and Q_1, Q_2, \dots, Q_h are monic and irreducible polynomials), then $B = A$, $k = h$ and for each $Q_j^{m_j}$, there is a P_i such that $Q_j = P_i$ and $m_j = n_i$.

PROOF. In formula (2.6) some α 's could be real numbers and some could be complex numbers. If for instance α_1 is a real number, then $P_1 = (x - \alpha_1)^{n_1}$. If α_i is a complex number (nonreal), then there is exactly an α_j between the roots $\alpha_1, \dots, \alpha_s$ of P such that $\alpha_j = \bar{\alpha}_i$ (see lemma 1) and $n_i = n_j$ (why?). Thus, the polynomial $(x - \alpha_i)(x - \alpha_j)$ is a monic irreducible polynomial with real coefficients (why?). Let us denote it by P_2 . Hence, the contribution of α_i and α_j to P is exactly $P_2^{n_2}$, where n_2 is the common value of n_i and n_j . We continue this reasoning on the roots of P up to obtaining the formula (2.10). Since $A = B = a_n$, the dominant coefficient of P , since any root α_h of P is a root of a P_t and of a Q_v at the same time and since P_t and Q_v are monic irreducible polynomials, we see that $P_t = Q_v$. Indeed, if α_h is a real number, then $P_t(x) = x - \alpha_h = Q_v(x)$. If α_h is a complex nonreal number, since P_t and Q_t are monic irreducible polynomials with real coefficients, we see that both of them must be equal to $(x - \alpha_h)(x - \bar{\alpha}_h)$ (why?). So, we have the required uniquenesses. \square

DEFINITION 2. (*the greatest common divisor*) Let P and Q be two nonzero polynomials. The monic polynomial D of maximum degree such that D is a divisor of P and of Q is said to be the greatest common divisor of P and Q . We denote D by (P, Q) .

For instance, if $P = x^4(x + 1)^2(x^2 + x + 1)$ and $Q = x^2(x + 1)^5$, then $D = (P, Q) = x^2(x + 1)^2$. In general, if

$$P = AP_1^{n_1}P_2^{n_2}\dots P_k^{n_k},$$

and

$$Q = BQ_1^{m_1}Q_2^{m_2}\dots Q_t^{m_t},$$

are the decompositions of P and respectively of Q , of type (2.10), such that $P_1 = Q_1, P_2 = Q_2, \dots, P_r = Q_r$ and all the others are distinct one to each other, then (why?)

$$D = P_1^{\min(n_1, m_1)}P_2^{\min(n_2, m_2)}\dots P_r^{\min(n_r, m_r)}.$$

Moreover, the roots of D are exactly the common roots of P and Q with the least multiplicities (look at the above example!). If D is 1, we say that P and Q are *coprime*. For instance, $P = 2x^2 + 2$ and $Q = x^3 + 1$ are coprime, but $P = x + 1$ and $Q = x^3 + 1$ are not coprime (why?).

THEOREM 9. D is the greatest common divisor of P and Q (P and Q are not zero) if and only if there exists two polynomials U_0 and V_0 such that

$$(2.11) \quad D = PU_0 + QV_0$$

and D is monic with the least degree such that D can be written as in (2.11). In particular, if P and Q are coprime, then there are two polynomials U_0 and V_0 such that

$$(2.12) \quad 1 = PU_0 + QV_0$$

PROOF. Let us define the following set of polynomials

$$(2.13) \quad S = \{H = PU + QV : U \text{ and } V \text{ are arbitrary polynomials in } \mathbb{R}[x]\}.$$

It is easy to see that the sum between two polynomials of S is also a polynomial in S .

If we multiply a polynomial of S by an arbitrary polynomial of $\mathbb{R}[x]$, we also get a polynomial of S (prove these two last statements). Let D be a (monic) nonzero polynomial of S of the least degree and let M be another polynomial of S . Let us apply the Euclid's algorithm for dividing M by D . We get

$$M = CD + R,$$

where $\deg R < \deg D$. Since $M, D \in S$, then $R = M - CD \in S$. Thus, $R = 0$ and so $M = CD$. Therefore D is a divisor of any polynomial of S . In particular, D divides P and Q ($P, Q \in S!$) Since $D \in S$, there are two polynomials U_0 and V_0 such that $D = PU_0 + QV_0$.

\implies) Let now G be the greatest common divisor of P and Q . Since G divides P and Q , G also divides D . But D also divides P and Q , thus the degree of D is at most equal to $\deg G$. Since G divides D , we have that $\deg G = \deg D$. Since D and G are both monic, we must have that $D = G$. Thus, for the greatest common divisor we have the relation (2.11).

\impliedby) Let D_0 be a monic nonzero polynomial of minimal degree such that

$$D_0 = PU_1 + QV_1 \in S.$$

Exactly like above we prove that D_0 is the greatest common divisor of P and Q .

The last statement is obvious. \square

Practically, we can find the greatest common divisor and its expression (2.11) by transferring the problem from polynomials P and Q to another pair of polynomials Q and R , where $\deg R < \deg Q$ (if $\deg P \geq \deg Q$). Then to another pair R and R_1 , where $\deg R_1 < \deg R$, etc. This idea directly comes from the Euclid's division algorithm. Indeed, assume that $\deg P \geq \deg Q$ (if $\deg Q > \deg P$, change P with Q , etc.) and divide P by Q . There are polynomials C and R such that $P = CQ + R$ and $\deg R < \deg Q$. It is easy to see that the greatest

common divisor of P and Q is equal to the greatest common divisor of Q and R (prove slowly!). Now divide Q by R and get $Q = C_1R + R_1$, with $\deg Q > \deg R > \deg R_1$. The greatest common divisor of Q and R is equal to the greatest common divisor of R and R_1 , and so on... up to a $R_j = 0$. Then R_{j-1} is exactly the greatest common divisor of P and Q eventually multiplied by a constant (in our above definition the greatest common divisor is a monic polynomial!) (prove all of these!).

Let for instance $P(x) = x^4 - x$ and $Q(x) = x^2 - 1$. It is not necessarily to use Euclid's division algorithm, but to successively diminish the degrees of P or of Q . Let us write:

$$\begin{aligned} x^4 - x &= x^2(x^2 - 1) + x^2 - x = x^2(x^2 - 1) + \\ &+ (x^2 - 1) - (x - 1) = (x^2 + 1)(x^2 - 1) - (x - 1). \end{aligned}$$

Since $(P, Q) = (x^2 - 1, x - 1)$ we go on with division:

$$x^2 - 1 = (x + 1)(x - 1),$$

the greatest common divisor of P and Q is $x - 1$ and

$$x - 1 = (x^4 - x)(-1) + (x^2 - 1)(x^2 + 1).$$

Thus, the polynomials U_0 and V_0 are

$$U_0(x) = (-1), \text{ and } V_0(x) = x^2 + 1$$

and they can be chosen such that $\deg U_0 < \deg Q$ and $\deg V_0 < P$.

A representation of D as in (2.11) with $\deg U_0 < \deg Q$ and $\deg V_0 < P$ is called a *canonical representation*.

THEOREM 10. *In a canonical representation for $D = 1$, U_0 and V_0 are uniquely determined.*

PROOF. Indeed, if

$$1 = PU_0 + QV_0 = PU'_0 + QV'_0,$$

then

$$(2.14) \quad P(U_0 - U'_0) = Q(V'_0 - V_0)$$

Since P and Q have no nontrivial factors (of degree greater than 1) in common, we see that $V'_0 - V_0$ is divisible by P and $U_0 - U'_0$ is divisible by Q . Since $\deg(U_0 - U'_0) < \deg Q$ and $\deg(V'_0 - V_0) < \deg P$, we must conclude that $V'_0 = V_0$ and $U_0 = U'_0$. \square

Let P and Q be two polynomials such that $P \neq 0$. The fraction $\frac{Q}{P}$ is called a *rational fraction*. A rational fraction $\frac{A}{Pm}$, where P is an irreducible polynomial and $\deg A < \deg P$ is called a *simple rational fraction*. An arbitrary polynomial is also called a simple fraction (with denominator 1). If P is an irreducible polynomial, n is a nonzero

natural number and Q is an arbitrary polynomial, then the fraction $\frac{Q}{P^n}$ is called a *simple block* (of fractions). Formulas (2.3) and (2.4) of corollary 2 says that any simple block $\frac{Q}{P^m}$ can be uniquely decomposed into simple fractions:

$$(2.15) \quad \frac{Q}{P^m} = \frac{A_0}{P^m} + \frac{A_1}{P^{m-1}} + \dots + \frac{A_{m-1}}{P} + S,$$

where $A_0, A_1, \dots, A_{m-1}, S$ are polynomials (some of them may be zero!) and $\deg A_j < \deg P$ for any $j = 0, 1, \dots, m-1$.

THEOREM 11. (*decomposition into partial fractions*) *Let Q and P be arbitrary polynomials with $P \neq 0$ and let*

$$(2.16) \quad P = AP_1^{n_1}P_2^{n_2}\dots P_k^{n_k},$$

be a decomposition of P into a product of irreducible factors and a constant A . Then the fraction $\frac{Q}{P}$ can be uniquely (up to the order of the terms!) written as a sum of blocks:

$$(2.17) \quad \frac{Q}{P} = \frac{1}{A} \left[\frac{Q_1}{P_1^{n_1}} + \frac{Q_2}{P_2^{n_2}} + \dots + \frac{Q_k}{P_k^{n_k}} \right],$$

where Q_1, Q_2, \dots, Q_k are (uniquely determined) polynomials. Since each block $\frac{Q_i}{P_i^{n_i}}$ can be uniquely represented as a sum of simple fractions:

$$(2.18) \quad \frac{Q_i}{P_i^{n_i}} = \frac{A_0^{(i)}}{P_i^{n_i}} + \frac{A_1^{(i)}}{P_i^{n_i-1}} + \dots + \frac{A_{n_i-1}^{(i)}}{P_i} + S_i,$$

we get the final decomposition of the fraction $\frac{Q}{P}$ as a sum of simple fractions:

$$\frac{Q}{P} = \frac{S}{A} + \frac{1}{A} \sum_{i=1}^k \left[\frac{A_0^{(i)}}{P_i^{n_i}} + \frac{A_1^{(i)}}{P_i^{n_i-1}} + \dots + \frac{A_{n_i-1}^{(i)}}{P_i} \right],$$

where A is a constant (the dominant coefficient of P), S is a polynomial ($S = \sum_{i=1}^k S_i$) and $A_j^{(i)}$, $i = 1, 2, \dots, k$ and $j = 0, 1, \dots, n_i - 1$ are polynomials with $\deg A_j^{(i)} < \deg P_i$ for each $i = 1, 2, \dots, k$ and $j = 0, 1, \dots, n_i - 1$. This decomposition is unique up to the order of terms in sum. Moreover, the degrees of the polynomials $A_j^{(i)}$ are 0 or 1 (because the degrees of P_i are 1 or 2).

PROOF. We have only to prove formula (2.17). Let us use mathematical induction on the number k of the irreducible factors $P_1^{n_1}, P_2^{n_2}, \dots, P_k^{n_k}$. If $k = 1$ we have nothing to prove. Assume that $k > 1$ and denote $P_2^{n_2}P_3^{n_3}\dots P_k^{n_k}$ by L . Suppose that the statement of the theorem is true for any nonzero natural number less than k and we shall prove it

for k . Since $P_1^{n_1}, P_2^{n_2}, \dots, P_k^{n_k}$ are monic irreducible and distinct one to each other, $P_1^{n_1}$ and L have no common roots. Indeed, if α is a root of $P_1^{n_1}$ and of L , then there is a $j \neq 1$ such that α is a root of P_1 and of P_j ; if α is real, P_1 and P_j are both equal to $x - \alpha$, a contradiction! (why?). If α is not real, let $\bar{\alpha}$ be the conjugate of α . Then P_1 and P_j are both equal to $(x - \alpha)(x - \bar{\alpha})$, again a contradiction! (why?). Thus $P_1^{n_1}$ and L are coprime and we can apply theorem 9, formula (2.12). So there are two uniquely defined polynomials V and U with $\deg V < \deg L$ and $\deg U < \deg P_1^{n_1}$ such that

$$P_1^{n_1}V + LU = 1$$

(see theorem 10). Let us multiply both sides by $\frac{Q}{P} = \frac{Q}{AP_1^{n_1}L}$. We get:

$$(2.19) \quad \frac{Q}{P} = \frac{1}{A} \left[\frac{QV}{L} + \frac{QU}{P_1^{n_1}} \right].$$

Let us put Q_1 instead of QU and let us see that the number of irreducible factors of L is $k - 1$. Applying the induction hypothesis we obtain the representation (L is monic, so $A = 1$ in this case!):

$$(2.20) \quad \frac{QV}{L} = \frac{Q_2}{P_2^{n_2}} + \dots + \frac{Q_k}{P_k^{n_k}},$$

where Q_2, Q_3, \dots, Q_k are uniquely defined polynomials. If we come back to formula (2.19) with this expression of $\frac{QV}{L}$, we get exactly formula (2.17). The other statement is a direct computational consequence of this last formula. \square

EXAMPLE 6. *Let us find the decomposition into simple fractions of the rational function $\frac{Q(x)}{P(x)} = \frac{x+1}{x^4+x^2}$. Since $P(x) = x^2(x^2 + 1)$, we have two blocks of simple fractions, one corresponding to the irreducible polynomial $P_1(x) = x$ and the other corresponding to the irreducible polynomial $P_2(x) = x^2 + 1$. Hence,*

$$(2.21) \quad \frac{x+1}{x^4+x^2} = \frac{A}{x^2} + \frac{B}{x} + \frac{Cx+D}{x^2+1}.$$

Thus,

$$\frac{x+1}{x^4+x^2} = \frac{A(x^2+1) + Bx(x^2+1) + (Cx+D)x^2}{x^4+x^2},$$

or

$$x+1 = (B+C)x^3 + (A+D)x^2 + Bx + A.$$

We identify the coefficients of both sides and obtain:

$$1 = A,$$

$$1 = B,$$

$$0 = A + D,$$

$$0 = B + C,$$

so $A = 1$, $B = 1$, $C = -1$ and $D = -1$. Therefore our decomposition is

$$(2.22) \quad \frac{x+1}{x^4+x^2} = \frac{1}{x^2} + \frac{1}{x} + \frac{-x-1}{x^2+1}.$$

3. Primitives of rational functions

We shall use now the basic properties of the integrals (primitives) and the above sketchy theory of rational functions in order to compute their primitives.

Let us compute for instance a primitive for the rational function which appeared in example 6, namely $\int \frac{x+1}{x^4+x^2} dx$. We use the linearity of \int in formula (2.22):

$$\begin{aligned} \int \frac{x+1}{x^4+x^2} dx &= \int \frac{1}{x^2} dx + \int \frac{1}{x} dx + \int \frac{-x-1}{x^2+1} dx = \\ &= \int x^{-2} dx + \int x^{-1} dx - \frac{1}{2} \int \frac{2x}{x^2+1} dx - \int \frac{1}{x^2+1} dx = \\ &= \frac{x^{-3}}{-3} + \ln|x| - \frac{1}{2} \ln(x^2+1) - \arctan x, \end{aligned}$$

because

$$\int \frac{2x}{x^2+1} dx = \int \frac{d(x^2+1)}{x^2+1} = \int \frac{du}{u} = \ln|u| = \ln(x^2+1).$$

Since any simple fraction has one of the following forms:

$$(3.1) \quad \frac{A}{x-\alpha}, \text{ where } A, \alpha \in \mathbb{R},$$

$$(3.2) \quad \frac{A}{(x-\alpha)^n}, \text{ where } A, \alpha \in \mathbb{R}, n \in \mathbb{N}^*, n \geq 2,$$

$$(3.3) \quad \frac{Ax+B}{x^2+bx+c}, \text{ where } A, b, c \in \mathbb{R}, \Delta = b^2 - 4c < 0,$$

$$(3.4) \quad \frac{Ax+B}{(x^2+bx+c)^n}, \text{ where } A, b, c \in \mathbb{R}, \Delta = b^2 - 4c < 0, n \geq 2,$$

we must show how to find a primitive for each of these cases.

Case 1

$$(3.5) \quad \int \frac{A}{x-\alpha} dx = A \int \frac{1}{x-\alpha} dx = A \ln|x-\alpha|.$$

Case 2

$$(3.6) \quad \int \frac{A}{(x-\alpha)^n} dx = A \int \frac{1}{(x-\alpha)^n} dx =$$

$$A \int (x-\alpha)^{-n} dx = A \frac{(x-\alpha)^{-n+1}}{-n+1}, \text{ if } n \geq 2.$$

Case 3 Since

$$\int \frac{Ax+B}{x^2+bx+c} dx = \frac{A}{2} \int \frac{2x+b}{x^2+bx+c} dx +$$

$$+ \left(-\frac{Ab}{2} + B \right) \int \frac{1}{x^2+bx+c} dx$$

and since

$$\int \frac{2x+b}{x^2+bx+c} dx = \ln(x^2+bx+c),$$

one can reduce everything to the computation of a primitive of the following type:

$$\int \frac{A}{x^2+bx+c} dx = A \int \frac{1}{(x+\frac{b}{2})^2+a^2} dx,$$

where $a = \sqrt{c - \frac{b^2}{4}}$. Thus,

$$(3.7) \quad \int \frac{A}{x^2+bx+c} dx = A \int \frac{d(x+\frac{b}{2})}{(x+\frac{b}{2})^2+a^2} =$$

$$= A \frac{1}{a} \arctan \frac{x+\frac{b}{2}}{a}.$$

Here we use the basic formula $\int \frac{1}{x^2+a^2} dx = \frac{1}{a} \arctan \frac{x}{a}$ (see formula (1.9)).

Case 4 Using a similar reasoning as in **Case 3** one can reduce the computation of the primitive of the simple fraction of formula (3.4) to the following primitive:

$$\int \frac{1}{(x^2+bx+c)^n} dx = \int \frac{d(x+\frac{b}{2})}{[(x+\frac{b}{2})^2+a^2]^n}.$$

Denoting $x + \frac{b}{2}$ by a new variable u we must compute the primitive $\int \frac{du}{(u^2+a^2)^n}$, for $n \geq 2$. For convenience we use the same variable x . Let us denote $I_n = \int \frac{dx}{(x^2+a^2)^n}$ for any $n > 0$ this time ($a \neq 0$). We know that

$$I_1 = \frac{1}{a} \arctan \frac{x}{a}.$$

Let $n > 1$. We shall construct now a recurrence formula for I_n :

$$\begin{aligned} I_n &= \frac{1}{a^2} \int \frac{x^2 + a^2 - x^2}{(x^2 + a^2)^n} dx = \frac{1}{a^2} \int \frac{1}{(x^2 + a^2)^{n-1}} dx - \\ &-\frac{1}{a^2} \int \frac{x^2}{(x^2 + a^2)^n} dx = \frac{1}{a^2} I_{n-1} - \frac{1}{2a^2} \int \frac{x}{(x^2 + a^2)^n} d(x^2 + a^2) = \\ &= \frac{1}{a^2} I_{n-1} - \frac{1}{2a^2} \left[\int x d \left(\frac{(x^2 + a^2)^{-n+1}}{-n+1} \right) \right]. \end{aligned}$$

Let us use now the formula of integrating by parts (see (1.20)) and compute

$$\int x d \left(\frac{(x^2 + a^2)^{-n+1}}{-n+1} \right) = x \frac{(x^2 + a^2)^{-n+1}}{-n+1} - \frac{1}{-n+1} \int \frac{1}{(x^2 + a^2)^{n-1}} dx,$$

Thus,

$$I_n = \frac{1}{a^2} I_{n-1} - \frac{1}{2a^2} \left[x \frac{(x^2 + a^2)^{-n+1}}{-n+1} - \frac{1}{-n+1} I_{n-1} \right],$$

or

$$(3.8) \quad I_n = \left[\frac{1}{a^2} - \frac{1}{2a^2(n-1)} \right] I_{n-1} + \frac{x}{2a^2(n-1)(x^2 + a^2)^{n-1}}.$$

For instance, let us compute $I_2 = \int \frac{dx}{(x^2 + a^2)^2}$.

$$(3.9) \quad I_2 = \frac{1}{2a^3} \tan^{-1} \frac{x}{a} + \frac{x}{2a^2(x^2 + a^2)}.$$

Here $\tan^{-1} x$ is another notation for $\arctan x$. Formula (3.8) can be used to compute I_n "from up to down", i.e. the computation of I_n reduces to the computation of I_{n-1} . The computation of I_{n-1} reduces to the computation of I_{n-2} , etc., up to the computation of $I_1 = \frac{1}{a} \arctan \frac{x}{a}$.

In the following examples we use the ideas and experience just exposed in the above four cases.

EXAMPLE 7. What is a primitive of $\frac{3}{4x+5}$, where x runs over an interval I which does not contain $x = -\frac{5}{4}$.

$$\int \frac{3}{4x+5} dx = \frac{3}{4} \int \frac{d(4x+5)}{4x+5} = \frac{3}{4} \int \frac{du}{u} = \frac{3}{4} \ln |u| = \frac{3}{4} \ln |4x+5|.$$

EXAMPLE 8. Let us compute a primitive of $f(x) = \frac{1}{(2x+5)^5}$, where x belongs to an interval I which does not contain $x = -\frac{5}{2}$.

$$\int \frac{1}{(2x+5)^5} dx = \frac{1}{2} \int (2x+5)^{-5} d(2x+5) = \frac{1}{2} \int u^{-5} du =$$

$$= \frac{1}{2} \frac{u^{-5+1}}{-5+1} = \frac{(2x+5)^{-4}}{-8}.$$

EXAMPLE 9. What is the set of all primitives of the function $f(x) = \frac{3x+2}{x^2+x+1}$, $x \in \mathbb{R}$?

$$\begin{aligned} \int \frac{3x+2}{x^2+x+1} dx &= 3 \int \frac{x+\frac{2}{3}}{x^2+x+1} dx = \frac{3}{2} \int \frac{2x+\frac{4}{3}}{x^2+x+1} dx = \\ &= \frac{3}{2} \int \frac{2x+1+\frac{1}{3}}{x^2+x+1} dx = \frac{3}{2} \int \frac{(x^2+x+1)'}{x^2+x+1} dx + \frac{1}{2} \int \frac{1}{x^2+x+1} dx = \\ &= \frac{3}{2} \int \frac{d(x^2+x+1)}{x^2+x+1} + \frac{1}{2} \int \frac{1}{\left(x+\frac{1}{2}\right)^2 + \frac{3}{4}} d\left(x+\frac{1}{2}\right) = \\ &= \frac{3}{2} \ln(x^2+x+1) + \frac{1}{2} \int \frac{1}{u^2 + \left(\frac{\sqrt{3}}{2}\right)^2} du = \frac{3}{2} \ln(x^2+x+1) + \\ &+ \frac{1}{2} \frac{1}{\frac{\sqrt{3}}{2}} \arctan \frac{u}{\frac{\sqrt{3}}{2}} = \frac{3}{2} \ln(x^2+x+1) + \frac{1}{\sqrt{3}} \arctan \frac{2\left(x+\frac{1}{2}\right)}{\sqrt{3}} = \\ &\frac{3}{2} \ln(x^2+x+1) + \frac{1}{\sqrt{3}} \arctan \frac{2x+1}{\sqrt{3}}. \end{aligned}$$

So the set of all primitives of $f(x) = \frac{3x+2}{x^2+x+1}$ is

$$\left\{ \frac{3}{2} \ln(x^2+x+1) + \frac{1}{\sqrt{3}} \arctan \frac{2x+1}{\sqrt{3}} + C \right\},$$

where C is an arbitrary constant.

EXAMPLE 10. Let us find a primitive for $f(x) = \frac{x+3}{(x^2+4x+6)^3}$, $x \in \mathbb{R}$.

$$\begin{aligned} I &= \int \frac{x+3}{(x^2+4x+6)^3} dx = \frac{1}{2} \int \frac{2x+4}{(x^2+4x+6)^3} dx + \\ (3.10) \quad &+ \int \frac{1}{(x^2+4x+6)^3} dx = \frac{1}{2} \int \frac{(x^2+4x+6)'}{(x^2+4x+6)^3} dx + \\ &+ \int \frac{1}{[(x+2)^2+2]^3} d(x+2) = \frac{1}{2} \int u^{-3} du + \int \frac{dv}{[v^2+(\sqrt{2})^2]^3}, \end{aligned}$$

where $u = x^2 + 4x + 6$ and $v = x + 2$. Let

$$I_3 = \int \frac{dv}{[v^2+(\sqrt{2})^2]^3}$$

and let us use successively the recurrence formula (3.8) (put v instead of x , 3 instead of n and $\sqrt{2}$ instead of a):

$$I_3 = \left[\frac{1}{2} - \frac{1}{4(3-1)} \right] I_2 + \frac{v}{4(3-1)(v^2+2)^2} = \frac{3}{8} I_2 + \frac{v}{8(v^2+2)^2}.$$

But, from formula (3.9) we get

$$I_2 = \frac{1}{4\sqrt{2}} \arctan \frac{v}{\sqrt{2}} + \frac{v}{4(v^2+2)},$$

thus

$$I_3 = \frac{3}{32\sqrt{2}} \arctan \frac{v}{\sqrt{2}} + \frac{3v}{32(v^2+2)} + \frac{v}{8(v^2+2)^2}.$$

Let us come back with this value of I_3 in (3.10) and find:

$$\begin{aligned} I &= \frac{1}{2} \int u^{-3} du + \int \frac{dv}{[v^2 + (\sqrt{2})^2]^3} = \\ &= \frac{1}{2} \frac{u^{-2}}{-2} + \frac{3}{32\sqrt{2}} \arctan \frac{v}{\sqrt{2}} + \frac{3v}{32(v^2+2)} + \frac{v}{8(v^2+2)^2}. \end{aligned}$$

Finally, we make $u = x^2 + 4x + 6$ and $v = x + 2$:

$$\begin{aligned} I &= -\frac{1}{4(x^2 + 4x + 6)^2} + \frac{3}{32\sqrt{2}} \tan^{-1} \frac{x+2}{\sqrt{2}} + \\ &+ \frac{3(x+2)}{32[(x+2)^2 + 2]} + \frac{x+2}{8[(x+2)^2 + 2]^2}. \end{aligned}$$

EXAMPLE 11. Compute $I = \int \frac{dx}{(x^2+a^2)(x^2+b^2)}$ for all values of a and b .

Case 1. $a = 0 = b$. Then

$$I = \int x^{-4} dx = \frac{x^{-3}}{-3}.$$

Case 2. $a = 0, b \neq 0$. Then we must decompose into simple fractions the integrand function: $\frac{1}{x^2(x^2+b^2)}$. Let us denote x^2 by u :

$$\frac{1}{u(u+b^2)} = \frac{A}{u} + \frac{B}{u+b^2},$$

or

$$1 = A(u+b^2) + Bu = (A+B)u + Ab^2.$$

So $A = b^{-2}$ and $B = -b^{-2}$. Coming back to x , we get

$$\frac{1}{x^2(x^2+b^2)} = \frac{b^{-2}}{x^2} - \frac{b^{-2}}{x^2+b^2}.$$

Thus,

$$(3.11) \quad \int \frac{1}{x^2(x^2 + b^2)} dx = b^{-2} \int x^{-2} dx - b^{-2} \int \frac{1}{x^2 + b^2} dx = \\ = b^{-2} \frac{x^{-1}}{-1} - b^{-2} \frac{1}{b} \arctan \frac{x}{b}.$$

Case 3. $a \neq 0, b = 0$. Then $I = \int \frac{1}{x^2(x^2 + a^2)} dx$. Use now formula (3.11) with a instead of b and find

$$\int \frac{1}{x^2(x^2 + a^2)} dx = a^{-2} \frac{x^{-1}}{-1} - a^{-2} \frac{1}{a} \arctan \frac{x}{a}.$$

Case 4. $a \neq 0, b \neq 0, a \neq b$. Let us take the fraction $\frac{1}{(x^2 + a^2)(x^2 + b^2)}$ and decompose it into simple fractions. Since this last expression is in fact a rational function of x^2 , let us put $u = x^2$ (it is easier to work with factors of degree one at denominator-why?). So

$$\frac{1}{(x^2 + a^2)(x^2 + b^2)} = \frac{A}{u + a^2} + \frac{B}{u + b^2}.$$

Thus,

$$1 = A(u + b^2) + B(u + a^2) = (A + B)u + Ab^2 + Ba^2.$$

Hence, $A + B = 0$ and $Ab^2 + Ba^2 = 1$, or $A = \frac{1}{b^2 - a^2}$ and $B = -\frac{1}{b^2 - a^2}$. Finally,

$$\int \frac{1}{(x^2 + a^2)(x^2 + b^2)} dx = \\ = \frac{1}{b^2 - a^2} \left[\int \frac{1}{x^2 + a^2} dx - \int \frac{1}{x^2 + b^2} dx \right] = \\ = \frac{1}{b^2 - a^2} \left[\frac{1}{a} \arctan \frac{x}{a} - \frac{1}{b} \arctan \frac{x}{b} \right]$$

Case 5. $a = b \neq 0$. Then $I = \int \frac{1}{(x^2 + a^2)^2} = I_2$, with the notation of formula (3.9). We use this last formula and find

$$I = \frac{1}{2a^3} \arctan \frac{x}{a} + \frac{x}{2a^2(x^2 + a^2)}.$$

4. Primitives of irrational and trigonometric functions

What is an irrational function? The big temptation were to say that such a function is a function "which is not rational"! But, it is not so! For instance $f(x) = \exp(x)$ is not a rational function (why?-prove it!) but it is also not an irrational one. We say that it is a *transcendental function*. "Easily" speaking, a function is irrational if it is "rational" and contains some radicals...The exact definition is the following. A function of two variables

$$P(x, y) = \sum_{i=0}^n \sum_{j=0}^m a_{ij} x^i y^j = a_{00} + a_{10}x + a_{01}y + \dots + a_{nm}x^n y^m,$$

where $a_{ij} \in \mathbb{R}$, is called a polynomial of two variables. A *rational function of two variables* $R(x, y)$ is a quotient of two polynomials $P(x, y)$, $Q(x, y)$ of two variables: $R(x, y) = \frac{P(x, y)}{Q(x, y)}$. An *algebraic function of one variable* is a root $y = f(x)$ of a nonzero polynomial $P(x, y) = a_0(x) + a_1(x)y + \dots + a_m(x)y^m$, where $a_i(x)$ are polynomials of one variable with coefficients in \mathbb{R} , i.e. $P(x, f(x)) = 0$ for any real number x in the definition domain of f . For instance, $y = \sqrt{x^2 + 1}$ is algebraic because it is a root of the equation $1 + x^2 - y^2 = 0$. An integral of the form $\int R(x, y)dx$, where $R(x, y)$ is a rational function and y is an algebraic function is called an *abelian integral* ("abelian" comes from the name of the great mathematician Niels Abel who systematically studied such integrals). If the algebraic function $y = f(x)$ can be expressed by radicals we say that $R(x, y)$ is an irrational function. For instance, $R(x, \sqrt{x^2 + 1}) = \frac{x + \sqrt{x^2 + 1}}{1 + 3\sqrt{x^2 + 1}}$ is an irrational function. Since primitives of some classes of irrational functions appears in many applications, we present here some modalities to compute them.

A. Primitives of the form $\int R(x, \sqrt{ax + b})dx, a \neq 0$

We can reduce the computation of such a primitive to the computation of a primitive of a rational function by the following change of variable: $u^2 = ax + b$ for $ax + b \geq 0, a \neq 0$ (a, b are fixed constants). Our primitive becomes

$$F(u) = \int R\left(\frac{u^2 - b}{a}, u\right) \frac{2u}{a} du.$$

Then $G(x) = F(\sqrt{ax + b})$ is a primitive of $R(x, \sqrt{ax + b})$ (see formula (1.18)).

EXAMPLE 12. Compute $I = \int \frac{1}{1+\sqrt{2x+3}} dx$. Write $u^2 = 2x + 3$, $2udu = 2dx \implies dx = udu$, so

$$\begin{aligned} I &= \int \frac{u}{1+u} du = \int \frac{u+1-1}{u+1} du = \int 1 du - \int \frac{1}{1+u} du = \\ &= u - \ln|u+1| = \sqrt{2x+3} - \ln(\sqrt{2x+3}+1). \end{aligned}$$

B. Primitives of the form $\int R(x, \sqrt{ax^2+bx+c}) dx$, $a \neq 0$, where ax^2+bx+c is not a perfect square

Assume that $a > 0$. Then

$$ax^2 + bx + c = \left(\sqrt{a}x + \frac{b}{2\sqrt{a}} \right)^2 + c - \frac{b^2}{4a}.$$

Let us make the following convention: if $c - \frac{b^2}{4a} > 0$, we denote it by δ^2 (any positive real number is a square!!); if $c - \frac{b^2}{4a} < 0$, we denote it by $-\delta^2$. Since $ax^2 + bx + c$ is not a perfect square, $c - \frac{b^2}{4a}$ cannot be zero. Thus, if we denote $\sqrt{a}x + \frac{b}{2\sqrt{a}} = u$, then $du = \sqrt{a}dx$ and our integral becomes

$$(4.1) \quad \int R\left(\frac{u - \frac{b}{2\sqrt{a}}}{\sqrt{a}}, \sqrt{u^2 \pm \delta^2}\right) \frac{1}{\sqrt{a}} du.$$

Assume now that $a < 0$. Then

$$ax^2 + bx + c = -\left(\sqrt{-a}x - \frac{b}{2\sqrt{-a}}\right)^2 + c - \frac{b^2}{4a}.$$

Now, always $c - \frac{b^2}{4a}$ is positive because $ax^2 + bx + c \geq 0$ (otherwise we cannot define the square root of it!). So this time we put $c - \frac{b^2}{4a} = \delta^2$. Making the change of variable $u = \sqrt{-a}x - \frac{b}{2\sqrt{-a}}$, $du = \sqrt{-a}dx$, we get

$$\int R\left(\frac{u + \frac{b}{2\sqrt{-a}}}{\sqrt{-a}}, \sqrt{\delta^2 - u^2}\right) \frac{1}{\sqrt{-a}} du.$$

Hence, we have to study the following three types of such integrals:

- B₁ : $\int R(x, \sqrt{x^2 + \delta^2}) dx$
- B₂ : $\int R(x, \sqrt{x^2 - \delta^2}) dx$ and
- B₃ : $\int R(x, \sqrt{\delta^2 - x^2}) dx$.

In order to eliminate the radical in B₁ and in B₂ one can use the (Euler) substitution

$$(4.2) \quad \sqrt{x^2 \pm \delta^2} = x + t,$$

where t is a new variable. Squaring in (4.2) we get

$$x = \frac{\pm\delta^2 - t^2}{2t}, \quad \sqrt{x^2 \pm \delta^2} = \frac{\pm\delta^2 + t^2}{2t} \quad \text{and} \quad dx = \frac{\mp\delta^2 - t^2}{2t^2} dt.$$

Thus our primitives B_1 and B_2 become

$$\int R\left(\frac{\pm\delta^2 - t^2}{2t}, \frac{\pm\delta^2 + t^2}{2t}\right) \frac{\mp\delta^2 - t^2}{2t^2} dt$$

which is a primitive of a rational function in the new variable t . Compute it by the methods described in the previous section and finally put $t = \sqrt{x^2 \pm \delta^2} - x$ (see formula (4.2)).

EXAMPLE 13. Let us compute $I = \int \sqrt{3x^2 - 4x + 1} dx$. First of all we must reduce the computation of I to one of the form B_1 or B_2 . Since

$$3x^2 - 4x + 1 = \left(\sqrt{3}x - \frac{2}{\sqrt{3}}\right)^2 - \frac{1}{3}.$$

Thus for $u = \sqrt{3}x - \frac{2}{\sqrt{3}}$, $dx = \frac{1}{\sqrt{3}} du$ and our primitive becomes

$$\frac{1}{\sqrt{3}} \int \sqrt{u^2 - \frac{1}{3}} du.$$

Let us make now an Euler substitution

$$(4.3) \quad \sqrt{u^2 - \frac{1}{3}} = u + t, \quad u = -\frac{\frac{1}{3} + t^2}{2t}, \quad du = -\frac{t^2 - \frac{1}{3}}{2t^2} dt,$$

so

$$\begin{aligned} \frac{1}{\sqrt{3}} \int \sqrt{u^2 - \frac{1}{3}} du &= -\frac{1}{4\sqrt{3}} \int \frac{t^4 - \frac{2}{3}t^2 + \frac{1}{9}}{t^3} dt = \\ &= -\frac{1}{4\sqrt{3}} \left[\frac{t^2}{2} - \frac{2}{3} \ln |t| - \frac{t^{-2}}{18} \right]. \end{aligned}$$

Coming back to the initial variable x we get ($t = \sqrt{u^2 - \frac{1}{3}} - u$, see formula (4.3)):

$$\begin{aligned} I &= -\frac{1}{4\sqrt{3}} \left[\frac{\left(\sqrt{u^2 - \frac{1}{3}} - u\right)^2}{2} - \frac{2}{3} \ln \left| \sqrt{u^2 - \frac{1}{3}} - u \right| - \right. \\ &\quad \left. - \frac{\left(\sqrt{u^2 - \frac{1}{3}} - u\right)^{-2}}{18} \right]. \end{aligned}$$

To find the expression of the primitive I in x we must put in this last expression $u = \sqrt{3}x - \frac{2}{\sqrt{3}}$, etc. (go on with computations up to the end).

In order to eliminate the radical in B_3 we can make the substitution:

$$(4.4) \quad \sqrt{\delta^2 - x^2} = xt + \delta.$$

Squaring and dividing by x we get:

$$(4.5) \quad -x = xt^2 + 2t\delta \implies x = -\frac{2t\delta}{t^2 + 1}, \quad dx = \frac{2t^2\delta - 2\delta}{(t^2 + 1)^2} dt,$$

$$(4.6) \quad \sqrt{\delta^2 - x^2} = \frac{-t^2\delta + \delta}{t^2 + 1}.$$

So

$$(4.7) \quad \int R(x, \sqrt{\delta^2 - x^2}) dx = \int R\left(-\frac{2t\delta}{t^2 + 1}, \frac{-t^2\delta + \delta}{t^2 + 1}\right) \frac{2t^2\delta - 2\delta}{(t^2 + 1)^2} dt,$$

which is a primitive of a rational function in the variable t . After finding it we put instead of t its expression from (4.4), $t = \frac{\sqrt{\delta^2 - x^2} - \delta}{x}$.

EXAMPLE 14. Let us use formula (4.7) to find the primitive of $I = \int \frac{1}{x + \sqrt{4 - x^2}} dx$.

For this we change the variable x with a new one t (like in (4.4)):

$$(4.8) \quad \sqrt{2^2 - x^2} = xt + 2.$$

So, using (4.5) we get

$$\begin{aligned} \int \frac{1}{x + \sqrt{4 - x^2}} dx &= \int \frac{1}{-\frac{4t}{t^2+1} + \frac{-2t^2+2}{t^2+1}} \frac{4t^2 - 4}{(t^2 + 1)^2} dt = \\ &= -2 \int \frac{t^2 - 1}{(t^2 + 2t - 1)(t^2 + 1)} dt. \end{aligned}$$

Since $t^2 + 2t - 1 = (t + 1 + \sqrt{2})(t + 1 - \sqrt{2})$, we have the following decomposition into simple fractions

$$\frac{t^2 - 1}{(t^2 + 2t - 1)(t^2 + 1)} = \frac{A}{t + 1 + \sqrt{2}} + \frac{B}{t + 1 - \sqrt{2}} + \frac{Ct + D}{t^2 + 1}.$$

An ugly computation leads to

$$(4.9) \quad A = -\frac{1 + \sqrt{2}}{4 + 2\sqrt{2}}, \quad B = -\frac{1}{4 + 2\sqrt{2}}, \quad C = D = \frac{1}{2}.$$

Thus

$$\begin{aligned} I &= -2 \int \frac{t^2 - 1}{(t^2 + 2t - 1)(t^2 + 1)} dt = -2A \int \frac{1}{t + 1 + \sqrt{2}} dt - \\ &= -2B \int \frac{1}{t + 1 - \sqrt{2}} dt - C \int \frac{d(t^2 + 1)}{t^2 + 1} - 2D \int \frac{1}{t^2 + 1} dt = \end{aligned}$$

(4.10)
 $= -2A \ln \left| t + 1 + \sqrt{2} \right| - 2B \ln \left| t + 1 - \sqrt{2} \right| - C \ln(t^2 + 1) - 2D \arctan t,$
 where A, B, C, D have the numerical values from formula (4.9). From (4.8) we get

$$t = \frac{\sqrt{4-x^2}-2}{x}.$$

With this last value of t we come in (4.10) and obtain

$$\begin{aligned} I = & -2A \ln \left| \frac{\sqrt{4-x^2}-2}{x} + 1 + \sqrt{2} \right| - \\ & -2B \ln \left| \frac{\sqrt{4-x^2}-2}{x} + 1 - \sqrt{2} \right| - \\ & -C \ln \left(\left[\frac{\sqrt{4-x^2}-2}{x} \right]^2 + 1 \right) - 2D \arctan \frac{\sqrt{4-x^2}-2}{x}. \end{aligned}$$

REMARK 2. To compute the primitive B_1 we also can use trigonometric substitutions. For instance, if in $I = \int R(x, \sqrt{x^2 + \delta^2}) dx$ we put $x = \delta \tan t$, we get

$$dx = \frac{\delta}{\cos^2 t} dt, \quad I = \int R(\delta \tan t, \frac{\delta}{|\cos t|}) \delta \frac{1}{\cos^2 t} dt.$$

This last primitive is a rational function of $\sin x$ and $\cos x$. We shall see later how to integrate a rational function of $\sin x$ and $\cos x$.

EXAMPLE 15. Let us make $x = a \tan t$ ($a > 0$) and compute

$$I = \int \sqrt{x^2 + a^2} dx = a^2 \int \frac{1}{\cos^3 t} dt = a^2 \int \frac{d(\sin t)}{\cos^4 t} = a^2 \int \frac{du}{(1-u^2)^2},$$

where $u = \sin t$. Since

$$\frac{1}{(1-u^2)^2} = \frac{A}{(1-u)^2} + \frac{B}{1-u} + \frac{C}{(1+u)^2} + \frac{D}{1+u},$$

we find $A = B = C = D = \frac{1}{4}$. So

$$\begin{aligned} I = & \frac{a^2}{4} \left[\int \frac{du}{(1-u)^2} + \int \frac{du}{1-u} + \int \frac{du}{(1+u)^2} + \int \frac{du}{1+u} \right] = \\ & \frac{a^2}{4} \left[\frac{1}{1-u} - \ln(1-u) - \frac{1}{1+u} + \ln(1+u) \right] = \frac{a^2}{4} \left(\frac{2u}{1-u^2} + \ln \frac{1+u}{1-u} \right). \end{aligned}$$

Coming back to t we obtain

$$I = \frac{a^2}{4} \left(\frac{2 \sin t}{\cos^2 t} + \ln \frac{1 + \sin t}{1 - \sin t} \right).$$

But $t = \arctan \frac{x}{a}$, thus I finally becomes:

$$I = \frac{a^2}{4} \left(\frac{2 \sin \left[\arctan \frac{x}{a} \right]}{\cos^2 \left[\arctan \frac{x}{a} \right]} + \ln \frac{1 + \sin \left[\arctan \frac{x}{a} \right]}{1 - \sin \left[\arctan \frac{x}{a} \right]} \right).$$

REMARK 3. To compute $\int R(x, \sqrt{x^2 - \delta^2}) dx$ we can use $\sinh x$ and $\cosh x$. Recall that $\sinh x = \frac{\exp x - \exp(-x)}{2}$ and $\cosh x = \frac{\exp x + \exp(-x)}{2}$. It is easy to see that

$$(4.11) \quad \cosh^2 x - \sinh^2 x = 1.$$

Hence, if we put $x = \delta \cosh t$ we get $dx = \delta \sinh t dt$ and $\sqrt{x^2 - \delta^2} = \delta |\sinh t|$. Thus our integral becomes a rational integral in $\sinh x$ and $\cosh x$.

To compute $\int R(x, \sqrt{\delta^2 - x^2}) dx$ we can use the trigonometric substitution $x = \delta \sin t$. Thus $dx = \delta \cos t dt$ and $\sqrt{\delta^2 - x^2} = \delta |\sin t|$. So our integral reduces to an integral of a rational function in $\sin x$ and $\cos x$.

C. Primitives of the form $\int x^m(ax^n + b)^p dx$, where m, n, p are nonzero rational numbers and $a, b \neq 0$

Let $m = \frac{m_1}{m_2}$, $n = \frac{n_1}{n_2}$ and $p = \frac{p_1}{p_2}$ be three nonzero rational numbers (fractions are simplified) with $m_1, n_1, p_1, m_2, n_2, p_2$ natural numbers and $m_2, n_2, p_2 > 0$. The expression $x^m(ax^n + b)^p dx$ is called a *binomial differential form*. If there is a differential function $F(x)$ such that $dF(x) = x^m(ax^n + b)^p dx$ we say that the binomial differential is *exact* and the function $F(x)$ is a *primitive* of it. A *substitution* or a change of the variable x with a new variable t is an equation of the type $g(x) = t$, where g is a diffeomorphism on a fixed interval J (g is of class C^1 and has an inverse $x = g^{-1}(t)$ also of class C^1). A substitution can be interpreted as a plane curve $h(x, t) = g(x) - t = 0$. The substitution is called "rational" if one can find a rational parameterization of the curve $h(x, t) = 0$, i.e. if one can find two rational functions $R_1(u)$, $R_2(u)$, where $u \in L$, a real interval, such that $h(R_1(u), R_2(u)) = 0$ for any $u \in L$. For instance, $(3x + 5)^{\frac{5}{3}} = t$ is a rational substitution because for $x = R_1(u) = \frac{u^3 - 5}{3}$, and $t = R_2(u) = u^5$, rational functions of u , one has: $(3R_1(u) + 5)^{\frac{5}{3}} = R_2(u)$. At the end of 19-th century, the great Russian mathematician P. L. Chebyshev proved a basic results on such binomial differential forms (on the existence of their primitives).

THEOREM 12. (*Cebychev*) *One can find an integral of a rational function starting from $\int x^m(ax^n + b)^p dx$, by making "rational" substitutions, if and only if m, n and p are in one of the following three situations:*

Case 1. p is an integer ($p_2 = 1$).

Case 2. p is not an integer but $\frac{m+1}{n}$ is an integer.

Case 3. p is not an integer, $\frac{m+1}{n}$ is not an integer, but $\frac{m+1}{n} + p$ is an integer.

PROOF. We prove only the fact that if we are in one of the three cases above, then the integral can be "rationalized", i.e. there is a sequence of "rational substitutions" of variables such that our binomial differential form $x^m(ax^n + b)^p dx$ becomes a rational differential form, i.e. a differential form of the type $Q(u)du$, where Q is a rational function in a new variable u . The reverse part of the theorem cannot be proved by elementary tools. It involves deep knowledge of Algebraic Geometry.

First of all let us make the natural substitution: $x^n = t$ (if $n \neq 1$; if $n = 1$ we pass directly to the second step of the following reasoning). Thus $x = t^{\frac{1}{n}}$ and $dx = \frac{1}{n}t^{\frac{1}{n}-1}dt$. Hence, our binomial integral becomes

$$(4.12) \quad \frac{1}{n} \int t^q (at + b)^p dt,$$

the *canonical form* of the binomial integral. Here we denoted $\frac{m+1}{n} - 1$ by q . In general, since $q = \frac{m+1}{n} - 1$ and p are rational numbers we have in the expression $t^{\frac{m+1}{n}-1}(at + b)^p$ two radicals. If we had only one radical, it could be easy to change the variable t with another one u such that the new differential form becomes rational. For instance, in $\int t^{-4}(3t + 4)^{-\frac{1}{3}} dt$ we have only one radical, so we "kill" it by the obvious substitution $3t + 4 = u^3$, or $t = \frac{u^3-4}{3}$ and $dt = u^2 du$. Thus our last integral becomes

$$3^4 \int (u^3 - 4)^{-4} u^{-1} u^2 du = 81 \int \frac{u}{(u^3 - 4)^4} du,$$

which is a primitive of a rational function. We decompose $\frac{u}{(u^3-4)^4}$ into simple fractions, etc.

Let us come back to our general case of the primitive (from formula (4.12)).

Case 1. p is an integer.

If q is also an integer, we have nothing to do, the integrand $t^q(at+b)^p$ being rational.

If $q = \frac{m+1}{n} - 1$ is not an integer, i.e. if $\frac{m+1}{n}$ is not an integer, $q = \frac{q_1}{q_2}$, simplified and q_1, q_2 integers with $q_2 \neq 1$, then the obvious substitution $t = u^{q_2}$ makes the binomial differential form $t^q(at+b)^p dt$ rational. Indeed,

$$t^q(at+b)^p dt = u^{q_1} (au^{q_2} + b)^p q_2 u^{q_2-1} du$$

is rational because q_1, q_2 and p are integers.

Case 2. p is not an integer, but $\frac{m+1}{n}$ is an integer. Let $p = \frac{p_1}{p_2}$, simplified and p_1, p_2 integers, with $p_2 \neq 1$. Then the substitution $at+b = u^{p_2}$ give rise to a rational differential form. Indeed, this time $q = \frac{m+1}{n} - 1$ is an integer, $t = \frac{u^{p_2}-b}{a}$ and $dt = \frac{p_2}{a} u^{p_2-1} du$, so

$$t^q(at+b)^p dt = \left(\frac{u^{p_2}-b}{a} \right)^q u^{p_1} \frac{p_2}{a} u^{p_2-1} du$$

is rational because p_1, p_2 and q are integers.

Case 3. $p = \frac{p_1}{p_2}$ is not an integer and $\frac{m+1}{n}$ is not an integer too.

In this case we make the following "trick" in the canonical differential form:

$$(4.13) \quad t^q(at+b)^p dt = t^{q+p} \left(\frac{at+b}{t} \right)^p dt.$$

We apply now the same idea like above.

If $q+p = \frac{m+1}{n} - 1 + p$ is an integer, i.e. if $\frac{m+1}{n} + p$ is an integer, then the obvious substitution $\frac{at+b}{t} = u^{p_2}$, where p_2 is the denominator of p , leads to a rational differential form. Indeed, this time

$$t = \frac{b}{u^{p_2}-a} = b(u^{p_2}-a)^{-1},$$

$$dt = -bp_2 u^{p_2-1} (u^{p_2}-a)^{-2} du,$$

so

$$t^{q+p} \left(\frac{at+b}{t} \right)^p dt = b^{q+p} (u^{p_2}-a)^{-(q+p)} u^{p_1} (-bp_2) u^{p_2-1} (u^{p_2}-a)^{-2} du.$$

Since $q+p, p_1$ and p_2 are integers, then this last differential form is rational and the implication " \Leftarrow " of the theorem is completely proved. \square

REMARK 4. The **case 3** which naturally appeared during the proof of the above theorem 12 can also be manipulated in the following way. Instead of the "trick" used in formula (4.13) we can use the following one:

$$(4.14) \quad t^q(at+b)^p dt = \left(\frac{t}{at+b} \right)^q (at+b)^{p+q} dt.$$

Since $q + p$ is an integer, and since $q = \frac{q_1}{q_2}$ is simplified with $q_2 \neq 1$ we make the natural substitution $\frac{t}{at+b} = u^{q_2}$ in order to "kill" the only radical which appears in (4.14) (because q is not an integer!!). Now, $t = b(u^{-q_2} - a)^{-1}$ and $dt = bq_2 u^{-q_2-1} (u^{-q_2} - a)^{-2} du$. Thus formula (4.14) becomes

$$\left(\frac{t}{at+b}\right)^q (at+b)^{p+q} dt = u^{q_1} (1 - au^{q_2})^{-(q+p)} bq_2 u^{-q_2-1} (u^{-q_2} - a)^{-2} du,$$

which is a rational differential form because $q+p$, q_1 and q_2 are integers.

We give now some examples in which we practically use the theory exposed above.

EXAMPLE 16. Reduce to an integral of a rational function and then compute the following integral: $\int \sqrt[3]{x} (2 + 3\sqrt{x})^{-2} dx$. Here $m = \frac{1}{3}$, $n = \frac{1}{2}$ and $p = -2$. Thus we are in Case 1 of the Cebyshev theorem. Let us make the canonical substitution

$$t = x^{\frac{1}{2}} \text{ or } x = t^2, dx = 2t dt.$$

So

$$\int \sqrt[3]{x} (2 + 3\sqrt{x})^{-2} dx = 2 \int t^{\frac{5}{3}} (2 + 3t)^{-2} dt.$$

Now we "kill" the radical $t^{\frac{5}{3}}$ by making the new substitution $t = u^3$. Thus

$$\begin{aligned} 2 \int t^{\frac{5}{3}} (2 + 3t)^{-2} dt &= 6 \int u^5 (2 + 3u^3)^{-3} u^2 du \stackrel{\text{by parts}}{=} \\ &= -\frac{1}{3} \int u^5 [(2 + 3u^3)^{-2}]' du = \\ &= -\frac{1}{3} \left\{ u^5 (2 + 3u^3)^{-2} - 5 \int u^4 (2 + 3u^3)^{-2} du \right\} = \\ &= -\frac{1}{3} \left\{ u^5 (2 + 3u^3)^{-2} + \frac{5}{9} \int u^2 [(2 + 3u^3)^{-1}]' du \right\} \stackrel{\text{by parts}}{=} \\ (4.15) \quad &= -\frac{1}{3} \left\{ u^5 (2 + 3u^3)^{-2} + \frac{5}{9} \left[u^2 (2 + 3u^3)^{-1} - 2 \int \frac{u}{2 + 3u^3} du \right] \right\}. \end{aligned}$$

This last integral

$$\int \frac{u}{2 + 3u^3} du = \frac{1}{3} \int \frac{u}{\frac{2}{3} + u^3} du = \frac{1}{3} \int \frac{u}{a^3 + u^3} du,$$

where $a = \sqrt[3]{\frac{2}{3}}$, is an integral of a rational function. We can integrate it by the usual methods of decomposing of the integrand $\frac{u}{a^3+u^3}$ into simple fractions:

$$\frac{u}{a^3 + u^3} = -\frac{1}{3a} \frac{1}{u + a} + \frac{1}{3a} \frac{u + a}{u^2 - ua + a^2}.$$

Hence,

$$\begin{aligned} \frac{1}{3} \int \frac{u}{a^3 + u^3} du &= -\frac{1}{9a} \int \frac{1}{u + a} du + \frac{1}{18a} \int \frac{2u - a + 3a}{u^2 - ua + a^2} du = \\ (4.16) \quad &-\frac{1}{9a} \ln |u + a| + \frac{1}{18a} \ln |u^2 - ua + a^2| + \frac{1}{6} \int \frac{1}{u^2 - ua + a^2} du. \end{aligned}$$

Let us evaluate this last integral:

$$(4.17) \quad \int \frac{1}{u^2 - ua + a^2} du = \int \frac{d(u - \frac{a}{2})}{(u - \frac{a}{2})^2 + (\frac{a\sqrt{3}}{2})^2} = \frac{2}{a\sqrt{3}} \arctan \frac{2u - a}{a\sqrt{3}}.$$

Coming back with this result to formula (4.16) we get:

$$\begin{aligned} \frac{1}{3} \int \frac{u}{a^3 + u^3} du &= -\frac{1}{9a} \ln |u + a| + \frac{1}{18a} \ln |u^2 - ua + a^2| + \\ &+ \frac{1}{3a\sqrt{3}} \arctan \frac{2u - a}{a\sqrt{3}}. \end{aligned}$$

Now we go back to formula (4.15) and find:

$$\begin{aligned} 2 \int t^{\frac{5}{3}} (2 + 3t)^{-2} dt &= -\frac{1}{3} \{u^5 (2 + 3u^3)^{-2} + \\ &+ \frac{5}{9} [u^2 (2 + 3u^3)^{-1} - \frac{2}{3} - \frac{1}{9a} \ln |u + a| + \frac{1}{18a} \ln |u^2 - ua + a^2| + \\ &+ \frac{1}{3a\sqrt{3}} \tan^{-1} \frac{2u - a}{a\sqrt{3}}] \}. \end{aligned}$$

Now, instead of u let us put $t^{\frac{1}{3}}$ and obtain:

$$\begin{aligned} 2 \int t^{\frac{5}{3}} (2 + 3t)^{-2} dt &= -\frac{1}{3} \{t^{\frac{5}{3}} (2 + 3t)^{-2} + \frac{5}{9} [t^{\frac{2}{3}} (2 + 3t)^{-1} - \\ &-\frac{2}{3} - \frac{1}{9a} \ln |t^{\frac{1}{3}} + a| + \frac{1}{18a} \ln |t^{\frac{2}{3}} - t^{\frac{1}{3}}a + a^2| + \frac{1}{3a\sqrt{3}} \tan^{-1} \frac{2t^{\frac{1}{3}} - a}{a\sqrt{3}}] \}. \end{aligned}$$

But $t = x^{\frac{1}{2}}$, so our initial integral is:

$$\int \sqrt[3]{x} (2 + 3\sqrt{x})^{-2} dx = -\frac{1}{3} \{x^{\frac{5}{6}} (2 + 3x^{\frac{1}{2}})^{-2} + \frac{5}{9} [x^{\frac{1}{3}} (2 + 3x^{\frac{1}{2}})^{-1} -$$

$$-\frac{2}{3} - \frac{1}{9a} \ln \left| x^{\frac{1}{6}} + a \right| + \frac{1}{18a} \ln \left| x^{\frac{1}{3}} - x^{\frac{1}{6}}a + a^2 \right| + \frac{1}{3a\sqrt{3}} \tan^{-1} \frac{2x^{\frac{1}{6}} - a}{a\sqrt{3}} \Big\}.$$

where $a = \sqrt[3]{\frac{2}{3}}$.

REMARK 5. The last example 16 is a very particular example of a more general situation. Let x_1, x_2, \dots, x_n be n independent variables. A monomial in these variables x_1, x_2, \dots, x_n is an expression of the form

$$a_{k_1, k_2, \dots, k_n} x_1^{k_1} x_2^{k_2} \dots x_n^{k_n},$$

where a_{k_1, k_2, \dots, k_n} is a real number and k_1, k_2, \dots, k_n are nonnegative integers (they may be also zero). A finite sum of such expressions is called a polynomial $P = P(x_1, x_2, \dots, x_n)$ in the n variables x_1, x_2, \dots, x_n . A rational function

$$R = R(x_1, x_2, \dots, x_n)$$

in n variables is a quotient $R = \frac{P}{Q}$ of two polynomials in n variables. A rational expression of simple radicals is obtained from a rational function

$R(x_1, x_2, \dots, x_n)$ in n variables by substituting the variable x_i with a radical expression of the form $\left(\frac{ax+b}{cx+d}\right)^{\frac{p_i}{q_i}}$, where x is our "old variable of integration", a, b, c, d are real numbers with $\det \begin{pmatrix} a & b \\ c & d \end{pmatrix} \neq 0$ and p_i, q_i are nonzero natural numbers. Here i goes from 1 up to n . Such a rational expression of simple radicals usually appears like:

$$(4.18) \quad R \left(\left(\frac{ax+b}{cx+d} \right)^{\frac{p_1}{q_1}}, \left(\frac{ax+b}{cx+d} \right)^{\frac{p_2}{q_2}}, \dots, \left(\frac{ax+b}{cx+d} \right)^{\frac{p_n}{q_n}} \right).$$

To integrate such a function of x we make the natural substitution

$$(4.19) \quad \frac{ax+b}{cx+d} = t^q,$$

where q is the least common multiple (lcm) of all the denominators q_1, q_2, \dots, q_n of the powers of $\frac{ax+b}{cx+d}$. It is clear that the new obtained differential form in t is a rational one. Indeed, starting from

$$\int R \left(\left(\frac{ax+b}{cx+d} \right)^{\frac{p_1}{q_1}}, \left(\frac{ax+b}{cx+d} \right)^{\frac{p_2}{q_2}}, \dots, \left(\frac{ax+b}{cx+d} \right)^{\frac{p_n}{q_n}} \right) dx,$$

after substitution, we get:

$$q(ad-bc) \int R(t^{s_1}, t^{s_2}, \dots, t^{s_n}) \frac{t^{q-1}}{(ct^{q-1} - a)^2} dt,$$

because, from (4.19) $x = \frac{t^q d - b}{a - t^q c}$ and $dx = q(ad - bc) \frac{t^{q-1}}{(ct^{q-1} - a)^2} dt$. Here $s_i = \frac{p_i}{q_i} q$ are natural numbers (why?). Thus, the obtained integral is an integral of a rational function in the variable t .

For instance, in our example 16 the common expression $\frac{ax+b}{cx+d}$ under radicals is simply x . Now, the rational function is $R(x_1, x_2) = x_1(2 + 3x_2)^{-2}$, $\frac{p_1}{q_1} = \frac{1}{3}$, $\frac{p_2}{q_2} = \frac{1}{2}$ and $q = \text{lcm}(3, 2) = 6$. So the natural substitution is $x = t^6$ and we get:

$$\int \sqrt[3]{x} (2 + 3\sqrt{x})^{-2} dx = 6 \int t^2 (2 + 3t^3)^{-2} t^5 dt,$$

etc.

EXAMPLE 17. Let us compute the integral $I = \int x^3 \sqrt[3]{1+x^2} dx$. Since $m = 3$, $n = 2$ and $p = \frac{1}{3}$, p is not an integer and $\frac{m+1}{n} = 2$ is an integer, we are in Case 2. We can see that it is possible to put directly

$$(4.20) \quad 1 + x^2 = u^3, u = \sqrt[3]{1+x^2}$$

(without making first of all $x^2 = t$, why?). Thus,

$$2x dx = 3u^2 du \implies dx = \frac{3u^2}{2x} du.$$

Let us come back to our differential form $x^3 \sqrt[3]{1+x^2} dx$ and perform these new substitutions:

$$x^3 \sqrt[3]{1+x^2} dx = x^3 u \frac{3u^2}{2x} du = \frac{3}{2} x^2 u^3 du = \frac{3}{2} (u^3 - 1) u^3 du.$$

So

$$\int \frac{3}{2} (u^3 - 1) u^3 du = \frac{3}{2} \left(\frac{u^7}{7} - \frac{u^4}{4} \right) = \frac{3}{14} (1+x^2)^{\frac{7}{3}} - \frac{3}{8} (1+x^2)^{\frac{4}{3}}.$$

EXAMPLE 18. Let us compute now $I = \int \frac{\sqrt{1+x^2}}{x^4} dx$. This is a binomial integral with $m = -4$, $n = 2$ and $p = \frac{1}{2}$. Since p is not an integer, $\frac{m+1}{n} = -\frac{3}{2}$ is also not an integer, but $\frac{m+1}{n} + p = -1$ is an integer (Case 3), we can directly make the substitution $\frac{1+x^2}{x^2} = u^2$ (because $t = x^2$ in formula (4.13)). So

$$1 + x^2 = u^2 x^2, x^2 = \frac{1}{u^2 - 1}, 2x dx = 2x^2 u du + 2u^2 x dx,$$

$$dx = \frac{x^2 u}{x - u^2 x} du = \frac{xu}{1 - u^2} du.$$

Thus, our differential form becomes (we consider only the case $x > 0$ and $u \in (1, \infty)$):

$$\begin{aligned} \frac{\sqrt{1+x^2}}{x^4} dx &= \frac{ux}{x^4} \frac{xu}{1-u^2} du = \frac{u^2}{x^2(1-u^2)} du = \\ &= \frac{u^2}{\left(\frac{1}{u^2-1}\right)(1-u^2)} du = -u^2 du. \end{aligned}$$

Finally we get:

$$\int \frac{\sqrt{1+x^2}}{x^4} dx = - \int u^2 du = -\frac{u^3}{3} = -\frac{1}{3} \left(\frac{1+x^2}{x^2} \right)^{\frac{3}{2}}.$$

The best idea is to make "formal" computations (not taking count of the definition domains of different expressions which appear during substitutions!) and, in the end, to verify by a direct differentiation the obtained result. In our example,

$$\left[-\frac{1}{3} \left(\frac{1+x^2}{x^2} \right)^{\frac{3}{2}} \right]' = \frac{\sqrt{1+x^2}}{x^4}, x \neq 0.$$

Hence, in spite of the required limitations which appeared during a particular computation, a primitive of the differential form $\frac{\sqrt{1+x^2}}{x^4} dx$, on each interval which does not contain 0, is $-\frac{1}{3} \left(\frac{1+x^2}{x^2} \right)^{\frac{3}{2}}$.

REMARK 6. In general, a primitive of the form

$$\int R(x, \sqrt{a_n x^n + a_{n-1} x^{n-1} + \dots + a_0}) dx,$$

where $a_n \neq 0$ and $n > 2$ is not an elementary function. By an elementary function we understand a function which is a composition of rational functions, trigonometric functions, exponential functions and logarithm functions. If $n = 3$ our primitive is called an elliptic integral. In general, if the integrand function is a rational expression which contains radicals of polynomials, then it is called an abelian integral (in memory of the great Norway mathematician, Niels Abel). For instance,

$$\begin{aligned} \int x^2 (2 + 5x^3)^{\frac{3}{5}} dx &= \frac{1}{15} \int (2 + 5x^3)^{\frac{3}{5}} d(2 + 5x^3) = \\ &= \frac{1}{15} \int u^{\frac{3}{5}} du = \frac{1}{15} \frac{u^{\frac{3}{5}+1}}{\frac{3}{5}+1} = \frac{1}{24} (2 + 5x^3)^{\frac{8}{5}}, \end{aligned}$$

is an elementary function. But, $\int \sqrt{1+x^4} dx$ is not an elementary function. Indeed, let us make $x^4 = t$. So, $x = t^{\frac{1}{4}}$, $dx = \frac{1}{4} t^{-\frac{3}{4}} dt$ and the

integral becomes:

$$\frac{1}{4} \int t^{-\frac{3}{4}} (1+t)^{\frac{1}{2}} dt.$$

The last integral is a binomial integral with $m = -\frac{3}{4}$, $n = 1$ and $p = \frac{1}{2}$. Since p is not an integer, $\frac{m+1}{n} = \frac{1}{4}$ is also not an integer and $\frac{m+1}{n} + p = \frac{3}{4}$ is not an integer, we are in no one of the three cases of the Chebyshev theorem. So we cannot reduce this primitive to a rational primitive by rational substitutions. O. K., but the question is still alive! Is there an elementary differentiable function $F(x)$ such that $F'(x) = \sqrt{1+x^4}$? The answer is no, but we need a lot of higher Mathematics to prove it!

D. Primitives of the form $\int R(\cos x, \sin x)dx$, where $R(x_1, x_2)$ is a rational function

The general method consists in the following change of variable. Assume that x belongs to an interval J on which the function $x \rightarrow \tan \frac{x}{2}$ is invertible and its inverse is of class C^1 . Since

$$\cos x = \frac{1 - \tan^2 \frac{x}{2}}{1 + \tan^2 \frac{x}{2}}, \quad \sin x = \frac{2 \tan \frac{x}{2}}{1 + \tan^2 \frac{x}{2}},$$

it is naturally to put $t = \tan \frac{x}{2}$, $x = 2 \arctan t$, $dx = \frac{2}{1+t^2} dt$, so

$$\int R(\cos x, \sin x) dx = \int R\left(\frac{1-t^2}{1+t^2}, \frac{2t}{1+t^2}\right) \frac{2}{1+t^2} dt,$$

which is an integral of a rational function, etc.

EXAMPLE 19. Let us use this substitution to compute

$$\begin{aligned} I &= \int \frac{1}{1 + \sin x + \cos x} dx. \\ I &= \int \frac{1}{1 + \frac{2t}{1+t^2} + \frac{1-t^2}{1+t^2}} \frac{2}{1+t^2} dt = \int \frac{1}{t+1} dt = \\ &= \ln |t+1| = \ln \left| \tan \frac{x}{2} + 1 \right|. \end{aligned}$$

REMARK 7. Sometimes this substitution is not indicated because it leads to a very complicated computation.

If $R(\cos x, \sin x)$ can be written as $S(\cos x) \sin x$ or as $T(\sin x) \cos x$, where $S(y)$ and $T(y)$ are rational functions, then our integral becomes either

$$\begin{aligned} (4.21) \quad \int R(\cos x, \sin x) dx &= \int S(\cos x) \sin x dx = \\ &= - \int S(\cos x) d(\cos x) = - \int S(u) du, \end{aligned}$$

where $u = \cos x$, or

$$(4.22) \quad \int R(\cos x, \sin x) dx = \int T(\sin x) \cos x dx = \\ = \int T(\sin x) d(\sin x) = \int T(v) dv,$$

where $v = \sin x$.

EXAMPLE 20. If we want to compute $I = \int \sin^4 x \cos^3 x dx$ by the general substitution $t = \tan \frac{x}{2}$, we get a very complicated integral of a rational function in t (why is it so complicated?)

$$I = \int \left(\frac{2t}{1+t^2} \right)^4 \left(\frac{1-t^2}{1+t^2} \right)^3 \frac{2}{1+t^2} dt.$$

But, if we use the substitution described in (4.22), we get:

$$I = \int \sin^4 x \cos^2 x \cos x dx = \int \sin^4 x (1 - \sin^2 x) d(\sin x) = \\ = \int v^4 (1 - v^2) dv = \frac{v^5}{5} - \frac{v^7}{7} = \frac{\sin^5 x}{5} - \frac{\sin^7 x}{7}.$$

REMARK 8. Suppose now that $\cos x$ and $\sin x$ appear to even powers in

$R(\cos x, \sin x)$. Then always one can write $R(\cos x, \sin x) dx$ as

$$S(\tan x) \frac{1}{\cos^2 x} dx = S(\tan x) d(\tan x) = S(u) du,$$

where $u = \tan x$ and S is a rational function of u (why all of these?). The substitution $u = \tan x$ can also be done even in other cases. For instance, $\int \frac{\sin x dx}{\sin^3 x + \cos^3 x}$ can be "rationalized" by putting $\tan x = u$.

EXAMPLE 21. Let us compute $I = \int \frac{\cos^2 x}{1 + \sin^2 x} dx$ by this last method (the general substitution $t = \tan \frac{x}{2}$ is not good at all!-why?). Since $1 + \tan^2 x = \frac{1}{\cos^2 x}$, and since $u = \tan x$ implies that $x = \tan^{-1} u$ and $dx = \frac{1}{1+u^2} du$, we get

$$\int \frac{\cos^2 x}{1 + \sin^2 x} dx = \int \frac{1}{\frac{1}{\cos^2 x} + \tan^2 x} dx = \int \frac{1}{(1 + 2u^2)(1 + u^2)} du.$$

We must decompose into simple fractions the rational expression

$$\frac{1}{(1 + 2u^2)(1 + u^2)}.$$

Do not you hurry to search for a decomposition of a general type:

$$\frac{1}{(1+2u^2)(1+u^2)} = \frac{Au+B}{1+2u^2} + \frac{Cu+D}{1+u^2},$$

because we can think of this rational expression as a rational function of $t = u^2$, so we simply search for a decomposition of the following type:

$$\frac{1}{(1+2u^2)(1+u^2)} = \frac{A}{1+2u^2} + \frac{B}{1+u^2}.$$

So $A = 2$ and $B = -1$. Hence,

$$\begin{aligned} \int \frac{\cos^2 x}{1+\sin^2 x} dx &= 2 \int \frac{1}{1+2u^2} du - \int \frac{1}{1+u^2} du = \\ &= \sqrt{2} \int \frac{1}{1+(\sqrt{2}u)^2} d(\sqrt{2}u) - \arctan u = \\ &= \sqrt{2} \arctan(\sqrt{2}u) - \arctan u = \sqrt{2} \arctan(\sqrt{2} \tan x) - x. \end{aligned}$$

Sometimes it is useful to extend the computations with primitives to functions of real variables but with values in the complex number field \mathbb{C} . Let $f(x) = f_1(x) + if_2(x)$, where $i = \sqrt{-1}$ and $f_1, f_2 : I \rightarrow \mathbb{R}$, are two continuous functions of real variable x . They are usually called the (real) components of f . So $f : I \rightarrow \mathbb{C}$ is continuous (see Analysis I, [P \bullet], sequences of complex numbers, etc.). Moreover, f is differentiable on I if and only if f_1 and f_2 are differentiable on I and then $f' = f_1' + if_2'$ (see for instance Analysis I, [P \bullet]). Thus

$$\int f(x)dx = \int f_1(x)dx + i \int f_2(x)dx.$$

(why?). Let us compute for instance

$$\begin{aligned} \int \exp(ix)dx &= \int \cos x dx + i \int \sin x dx = \sin x - i \cos x = \\ &= \frac{1}{i} (\cos x + i \sin x) = \frac{1}{i} \exp(ix). \end{aligned}$$

We see from here that the usual rules for computing primitives of the real valued functions extends naturally to complex valued functions of real variables. This is true because such extension works in the case of the differential calculus (see Analysis I, [P \bullet]). So we can directly write

$$\begin{aligned} \int \exp(ix)dx &= \frac{1}{i} \int \exp(ix)d(ix) = \frac{1}{i} \int \exp u du = \frac{1}{i} \exp u = \\ &= \frac{1}{i} \exp(ix) = -i \exp(ix). \end{aligned}$$

(i is a constant complex number). These simple ideas are very helpful in computing usual primitives of real valued functions.

EXAMPLE 22. Let a, b be two real numbers and let

$I(a, b) = \int \exp(ax) \sin(bx) dx$ be a primitive of $\exp(ax) \sin(bx)$. Assume that $a, b \neq 0$ (otherwise the integral is trivial!). We can compute $I(a, b)$ by integrating by parts two times:

$$\begin{aligned} I(a, b) &= \int \exp(ax) \left[-\frac{1}{b} \cos(bx) \right]' dx = \\ &\stackrel{\text{by parts}}{=} -\frac{1}{b} \exp(ax) \cos(bx) + \frac{a}{b} \int \exp(ax) \cos(bx) dx = \\ &\quad -\frac{1}{b} \exp(ax) \cos(bx) + \frac{a}{b^2} \int \exp(ax) [\sin(bx)]' dx = \\ &\stackrel{\text{by parts}}{=} -\frac{1}{b} \exp(ax) \cos(bx) + \frac{a}{b^2} \{ \exp(ax) \sin(bx) - aI(a, b) \} = \\ &= \frac{a}{b} \exp(ax) \left[\frac{\sin(bx)}{b} - \frac{\cos(bx)}{a} \right] - \frac{a^2}{b^2} I(a, b). \end{aligned}$$

So

$$\left(1 + \frac{a^2}{b^2} \right) I(a, b) = \frac{a}{b} \exp(ax) \left[\frac{\sin(bx)}{b} - \frac{\cos(bx)}{a} \right],$$

or

$$\begin{aligned} I(a, b) &= \frac{ab}{a^2 + b^2} \exp(ax) \left[\frac{\sin(bx)}{b} - \frac{\cos(bx)}{a} \right] = \\ &= \frac{1}{a^2 + b^2} \exp(ax) [a \sin(bx) - b \cos(bx)]. \end{aligned}$$

Another smarter way to compute this integral is based on the above ideas. Let $J(a, b) = \int \exp(ax) \cos(bx) dx$ and let the complex number

$$\begin{aligned} J(a, b) + iI(a, b) &= \int \exp(ax) \exp(ibx) dx = \\ &= \int \exp[(a + bi)x] dx = \frac{1}{a + bi} \exp[(a + bi)x] = \\ &= \frac{a - bi}{a^2 + b^2} \exp(ax) \exp(ibx) = \frac{\exp(ax)}{a^2 + b^2} (a - ib) [\cos(bx) + i \sin(bx)] = \\ &= \frac{\exp(ax)}{a^2 + b^2} [a \cos(bx) + b \sin(bx)] + i \frac{\exp(ax)}{a^2 + b^2} [a \sin(bx) - b \cos(bx)]. \end{aligned}$$

Thus

$$J(a, b) = \frac{\exp(ax)}{a^2 + b^2} [a \cos(bx) + b \sin(bx)]$$

and

$$I(a, b) = \frac{\exp(ax)}{a^2 + b^2} [a \sin(bx) - b \cos(bx)].$$

REMARK 9. A way to compute primitives of the form

$$\int R(\cos mx, \sin nx) dx,$$

where m, n are natural nonzero numbers is to use Euler's formulas:

$$(4.23) \quad \cos mx = \frac{\exp(imx) + \exp(-imx)}{2},$$

$$(4.24) \quad \sin nx = \frac{\exp(inx) - \exp(-inx)}{2i}$$

and to reduce the computation to a primitive of a complex valued function (of a real variable).

EXAMPLE 23. Let us compute a primitive for the trigonometric differential form $\sin 3x \cos^4 x dx$.

Since $\sin 3x = \frac{\exp(3ix) - \exp(-3ix)}{2i}$ and since

$$\begin{aligned} \cos^2 x &= \frac{1 + \cos 2x}{2} = \frac{1}{2} + \frac{\exp(2ix) + \exp(-2ix)}{4} = \\ &= \frac{1}{4} [2 + \exp(2ix) + \exp(-2ix)], \end{aligned}$$

$$\cos^4 x = \frac{1}{16} [6 + \exp(4ix) + \exp(-4ix) + 4 \exp(2ix) + 4 \exp(-2ix)],$$

one has

$$\begin{aligned} \int \sin 3x \cos^4 x dx &= \frac{1}{32i} \int [\exp(3ix) - \exp(-3ix)] \times \\ &\quad \times [6 + \exp(4ix) + \exp(-4ix) + 4 \exp(2ix) + 4 \exp(-2ix)] dx = \\ &= \frac{1}{32i} \int [6 \exp(3ix) + \exp(7ix) + \exp(-ix) + 4 \exp(5ix) + 4 \exp(ix) - \\ &\quad - 6 \exp(-3ix) - \exp(ix) - \exp(-7ix) - 4 \exp(-ix) - 4 \exp(-5ix)] dx = \\ &= \frac{1}{16} \int [6 \sin(3x) + \sin(7x) + 3 \sin x + 4 \sin 5x] dx = \\ &\quad -\frac{1}{8} \cos 3x - \frac{1}{112} \cos 7x - \frac{3}{16} \cos x - \frac{1}{20} \cos 5x. \end{aligned}$$

EXERCISE 2. Let $I_n = \int \sin^n x dx$, where $n > 2$, and $n = 2k$ is even ($k > 1$). If n is odd it is easier to write

$$\sin^n x dx = -\sin^{n-1} x d(\cos x) = -(1-u^2)^{\frac{n-1}{2}} du,$$

etc. Let us compute I_n by firstly finding a recurrence formula:

$$\begin{aligned} I_{2k} &= \int \sin^{2k} x dx = \int (\sin^{2k-2} x) (1 - \cos^2 x) dx = \\ &= I_{2k-2} - \int \sin^{2k-2} x \cos x d(\sin x) \stackrel{\text{by parts}}{=} \\ &= I_{2k-2} - [\sin^{2k-1} x \cos x - \\ &- \int \sin x \{(2k-2) \sin^{2k-3} x \cos^2 x - \sin^{2k-1} x\} dx] = \\ &= I_{2k-2} - \sin^{2k-1} x \cos x + (2k-2) \int \sin^{2k-2} x (1 - \sin^2 x) dx - I_{2k} = \\ &= (2k-1)I_{2k-2} - (2k-1)I_{2k} - \sin^{2k-1} x \cos x, \end{aligned}$$

or

$$(4.25) \quad I_{2k} = \frac{2k-1}{2k} I_{2k-2} - \frac{1}{2k} \sin^{2k-1} x \cos x, \quad k \geq 1,$$

because it is easy to see that this last formula works even for $k = 1$.

EXAMPLE 24. For instance, since

$$\begin{aligned} I_2 &= \int \sin^2 x dx = \frac{1}{2} \int (1 - \cos 2x) dx = \\ &= \frac{1}{2} \left(x - \frac{\sin 2x}{2} \right) = \frac{1}{2} (x - \sin x \cos x), \end{aligned}$$

one has from (4.25) that

$$(4.26) \quad \int \sin^4 x dx = \frac{3}{4} \left[\frac{1}{2} (x - \sin x \cos x) \right] - \frac{1}{4} \sin^3 x \cos x.$$

Another way to compute such an integral is to express $\sin^n x$ as a polynomial of different powers of $\exp(ix)$ or $\exp(-ix)$:

$$\begin{aligned} \sin^n x &= \left[\frac{\exp(ix) - \exp(-ix)}{2i} \right]^n = \\ &= \frac{1}{2^n i^n} [\exp(inx) - \binom{n}{1} \exp i(n-2)x + \\ &+ \binom{n}{2} \exp i(n-4)x - \dots]. \end{aligned}$$

So

$$\begin{aligned} \int \sin^n x dx &= \\ &= \frac{1}{2^n i^n} \left[\int \exp(inx) dx - \binom{n}{1} \int \exp i(n-2)x dx + \right. \\ &\quad \left. + \binom{n}{2} \int \exp i(n-4)x dx - \dots \right]. \end{aligned}$$

For instance,

$$\begin{aligned} \int \sin^4 x dx &= \frac{1}{16} \left[\int \exp(4ix) dx - 4 \int \exp(2ix) dx \right] + \\ &+ \frac{6}{16} \left[\int dx - 4 \int \exp(-2ix) dx + \int \exp(-4ix) dx \right] = \\ \frac{1}{16} \left[\frac{\exp(4ix)}{4i} - 4 \underbrace{\frac{\exp(2ix)}{2i}} + 6x - 4 \underbrace{\frac{\exp(-2ix)}{-2i}} + \frac{\exp(-4ix)}{-4i} \right] &= \\ \frac{1}{16} \left[\frac{1}{2} \sin 4x - 4 \sin 2x + 6x \right]. \end{aligned}$$

An elementary trigonometric computation tells us that this expression is exactly that one from (4.26). Moreover, it is more beautiful, because it has no powers of trigonometric functions! These last ones are "not desirable" during the integration computation.

REMARK 10. *It is very useful to know that the following primitives are not elementary functions: $\int \frac{\exp x}{x} dx$; $\int \frac{\sin x}{x} dx$; $\int \frac{\cos x}{x} dx$; $\int \frac{\sinh x}{x} dx$; $\int \frac{\cosh x}{x} dx$; $\int \sin x^2 dx$; $\int \cos x^2 dx$; $\int \exp(-x^2) dx$; $\int \frac{1}{\ln x} dx$; $\int \frac{d\varphi}{\sqrt{1-k^2 \sin^2 \varphi}}$; $\int \sqrt{1-k^2 \sin^2 \varphi} d\varphi$; $\int \frac{d\varphi}{(1+h \sin^2 \varphi) \sqrt{1-k^2 \sin^2 \varphi}}$, where $k, h \in (-1, 1) \setminus \{0\}$ (elliptic integrals). Proofs for such statements belong to very high Mathematics. It implies deep knowledge of Algebraic Geometry and Algebraic Functions Theory. We note that not all the above statements are "independent" one to each other". For instance, if $\int \frac{\exp x}{x} dx$ is not an elementary function, then $\int \frac{1}{\ln x} dx$ is also not an elementary function. Indeed, let $F(x) = \int \frac{1}{\ln x} dx$, a primitive of the differential form $\frac{1}{\ln x} dx$. Let us make the substitution $x = \exp(t)$ in this last differential form:*

$$\frac{1}{\ln x} dx = \frac{\exp t}{t} dt.$$

So a primitive of $\frac{\exp t}{t} dt$ is $F(\exp(t))$ on any interval I which does not contain 0 (prove it!). But, if F were elementary, then $F(\exp(t))$

would also be elementary (as a composition between two elementary functions), a contradiction (explain everything slowly!). Try to find other pairs of "dependent" primitives in the above row of primitives!

Remark 10 is very useful in practice. For instance, if in the statement of an exercise there is a mistake: instead of $\int \frac{1}{x \ln x} dx$, $x > 0$, one omitted "an x " and it appears $\int \frac{1}{\ln x} dx$, you may spend a lot of time "to compute" this last primitive!! All this effort is for nothing! Because "to compute" usually means to work only with elementary functions! Indeed, the primitive $\int \frac{1}{\ln x} dx$ is not an elementary function (see remark 10), while

$$\int \frac{1}{x \ln x} dx = \int \frac{1}{\ln x} d(\ln x) = \int \frac{1}{u} du = \ln |u| = \ln |\ln x|,$$

is an elementary one!

EXAMPLE 25. We know that a canonical parametrization of the ellipse $\frac{x^2}{a^2} + \frac{y^2}{b^2} = 1$, $a, b > 0$, and $a < b$, is the following

$$x = x(t) = a \cos t, \quad y = y(t) = b \sin t, \quad t \in [0, 2\pi).$$

To compute the length of an arc of this ellipse, one reaches the following primitive (see Chapter 2, Section 8):

$$\begin{aligned} \int \sqrt{a^2 \sin^2 t + b^2 \cos^2 t} dt &= \int \sqrt{a^2 \sin^2 t + b^2(1 - \sin^2 t)} dt = \\ &= \int \sqrt{b^2 - (b^2 - a^2) \sin^2 t} dt = b \int \sqrt{1 - k^2 \sin^2 t} dt, \end{aligned}$$

where $k = \frac{\sqrt{b^2 - a^2}}{b}$. This last primitive is not an elementary function (see remark 10). It is called an "elliptic integral" because of this above problem which generated such a primitive.

5. Problems and exercises

1. Prove the following formulas and indicate the maximum definition domains of their existence (recall that by $\int f(x) dx$ we mean a primitive of the differential form $f(x) dx$):

- a) $\int \frac{1}{x^2 - a^2} dx = \frac{1}{2a} \ln \left| \frac{x-a}{x+a} \right|$, $a \neq 0$.
- b) $\int \frac{1}{x^2 + a^2} dx = \frac{1}{a} \arctan \frac{x}{a}$, $a \neq 0$.
- c) $\int \frac{1}{\sqrt{x^2 + a}} dx = \ln(x + \sqrt{x^2 + a})$, $a \neq 0$.
- d) $\int \frac{1}{\sqrt{a^2 - x^2}} dx = \arcsin \frac{x}{a}$, $a \neq 0$.
- e) $\int \sqrt{a^2 - x^2} dx = \frac{x}{2} \sqrt{a^2 - x^2} + \frac{a^2}{2} \arcsin \frac{x}{a}$, $a \neq 0$.
- f) $\int \sqrt{x^2 \pm a^2} dx = \frac{x}{2} \sqrt{x^2 \pm a^2} \pm \frac{a^2}{2} \ln(x + \sqrt{x^2 \pm a^2})$, $a \neq 0$.
- g) $\int \frac{1}{\sin^2 x} dx = -\cot x$; $\int \frac{1}{\cos^2 x} dx = \tan x$.

- h) $\int \tan x dx = -\ln |\cos x|$.
 i) $\int \cot x dx = \ln |\sin x|$.
 j) $\int \frac{1}{\sin x} dx = \ln \left| \tan \frac{x}{2} \right|$.
 k) $\int \frac{1}{\cos x} dx = \ln \left| \tan \left(\frac{\pi}{4} - \frac{x}{2} \right) \right|$.
 l) $\int \frac{1}{\cosh^2 x} dx = \frac{\sinh x}{\cosh x} (= \tanh x)$.
 m) $\int \frac{1}{\sinh^2 x} dx = -\frac{\cosh x}{\sinh x} (= -\coth x)$.

$$\text{n) } \int |x| dx = \text{sign}(x) \frac{x^2}{2}, \text{ where } \text{sign}(x) = \begin{cases} 1, & \text{if } x > 0 \\ 0, & \text{if } x = 0 \\ -1, & \text{if } x < 0 \end{cases}.$$

2. Use basic formulas, basic properties and basic methods to compute (where your result works on?):

- a) $\int \frac{x^4 + \sqrt[3]{x} + 3x^2 - 1}{\sqrt{x}} dx$; b) $\int \frac{x^3 + x^2 + 2x + 1}{x-1} dx$; c) $\int \sqrt[3]{3-2x} dx, n = 2, 3, \dots$;
 d) $\int \frac{x+1}{\sqrt{x^2+1}} dx$; e) $\int \frac{1}{\sqrt{7-5x^2}} dx$; f) $\int \frac{3^{2x}-1}{3^x} dx$; g) $\int \frac{x}{\cos^2(5x)} dx$;
 h) $\int \frac{5-3x}{\sqrt{4-3x^2}} dx$; i) $\int \frac{1}{x(4-\ln^2 x)} dx$; j) $\int \frac{1}{1+\cos^2 x} dx$; k) $\int \frac{\exp(2x)}{\exp(4x)+5} dx$;
 l) $\int \frac{1}{\sqrt{x}(1+\sqrt[3]{x})} dx$; m) $\int \frac{1}{A^2 \sin^2 x + B^2 \cos^2 x} dx$, where $AB \neq 0$;
 n) $\int \frac{1}{x^2 \sqrt{x^2+a^2}} dx, a \neq 0$; o) $\int \frac{1}{(a^2-x^2)^{\frac{3}{2}}} dx$; p) $\int \frac{1}{1+\sqrt[3]{1+x}} dx$; q) $\int \frac{1}{x\sqrt{1+x^2}} dx$;
 r) $B = \int x^2 \exp(x) \sin x dx$; Hint: consider $A = \int x^2 \exp(x) \cos x dx$ and compute by parts $A + iB$.
 s) $\int \exp(ax) \sin(bx) dx$;

3. Prove that $\int P(x) \exp(ax) dx = \exp(ax) \left[\frac{P}{a} - \frac{P'}{a^2} + \frac{P''}{a^3} - \dots \right]$, where $a \neq 0$ and P is a polynomial. Use this formula to compute $\int x^6 \exp(5x) dx$. Find similar formulas for computing $\int P(x) \sin(ax) dx$ and $\int P(x) \cos(ax) dx$. Use them to find $\int (x^6 + x^5 + 1) \sin 7x dx$.

4. Justify the formula:

$$\int u(x) [v(x)]^{(n+1)} dx = u(x) [v(x)]^{(n)} - u'(x) [v(x)]^{(n-1)} + \dots + (-1)^{n+1} \int [u(x)]^{(n+1)} v(x) dx.$$

Use it to compute $\int (x^5 + x + 1) \exp(2x) dx$.

5. Are the primitives $\int \frac{\ln^2 x}{\sqrt{x^5}} dx, x > 0$ and $\int \frac{x^2 \exp(x)}{(x+2)^2} dx$ elementary functions? If yes, compute them!

6. Use the recurrence formula for $I_n = \int \frac{dx}{(x^2+a^2)^n}$ to compute $\int \frac{dx}{(x^2+2x+5)^3}$.

CHAPTER 2

Definite integrals

1. The mass of a linear bar

By a *linear bar* we mean a closed interval $[a, b]$ and a nonnegative continuous function $f : [a, b] \rightarrow \mathbb{R}_+$. We call this last function f the *density function* of the bar. Let us divide the interval $[a, b]$ into n subintervals $[x_{i-1}, x_i]$, where $a = x_0 < x_1 < x_2 < \dots < x_n = b$, $i = 1, 2, \dots, n$. This last sequence $\{x_i\}_i$ of real numbers is called a *division* Δ of the interval $[a, b]$. The greatest length of all of the segments $\{[x_{i-1}, x_i]\}$, $i = 1, 2, \dots, n$ is said to be the *norm* $\|\Delta\|$ of the division Δ . Let us denote by

$$(1.1) \quad \omega_f[x_{i-1}, x_i] = \sup_{x', x'' \in [x_{i-1}, x_i]} \{|f(x') - f(x'')|\},$$

the *variation* of f over the interval $[x_{i-1}, x_i]$, i.e. the length of the interval $f([x_{i-1}, x_i])$ if f is continuous. Recall that a function $f : [a, b] \rightarrow \mathbb{R}$ is uniformly continuous if for any small real number $\varepsilon > 0$ there is a real number $\delta_\varepsilon > 0$ such that whenever x', x'' are in $[a, b]$ and $|x' - x''| < \delta_\varepsilon$, one has that $|f(x') - f(x'')| < \varepsilon$. It is clear enough that a uniformly continuous function is also a continuous one (why?). Since our continuous function f is also uniformly continuous on $[a, b]$ (see [Po], Th. 59), for any small number $\varepsilon > 0$, one can find a $\delta_\varepsilon > 0$, such that for any division

$$\Delta : a = x_0 < x_1 < x_2 < \dots < x_n = b$$

with $\|\Delta\| < \delta_\varepsilon$, the variation $\omega_f[x_{i-1}, x_i]$ is less than ε . This means that one can well approximate the density function f on the subinterval $[x_{i-1}, x_i]$ with any fixed value $f(\xi_i)$ of f at a fixed point $\xi_i \in [x_{i-1}, x_i]$. The set of the fixed points $\{\xi_i\}$, $\xi_i \in [x_{i-1}, x_i]$, $i = 1, 2, \dots, n$ is called a set of *marking points* for the division Δ . Thus, the *mass of the bar* can be well approximated by the sum:

$$(1.2) \quad S(f; \Delta; \{\xi_i\}) = \sum_{i=1}^n f(\xi_i)(x_i - x_{i-1}).$$

Such a sum $S(f; \Delta; \{\xi_i\})$ is called the *Riemann sum* associated to the function $f : [a, b] \rightarrow \mathbb{R}$, the division Δ and to the set of marking

points $\{\xi_i\}$. We also can interpret the Riemann sum $S(f; \Delta; \{\xi_i\})$ as the sum of the hatched areas of rectangles in Fig.1.

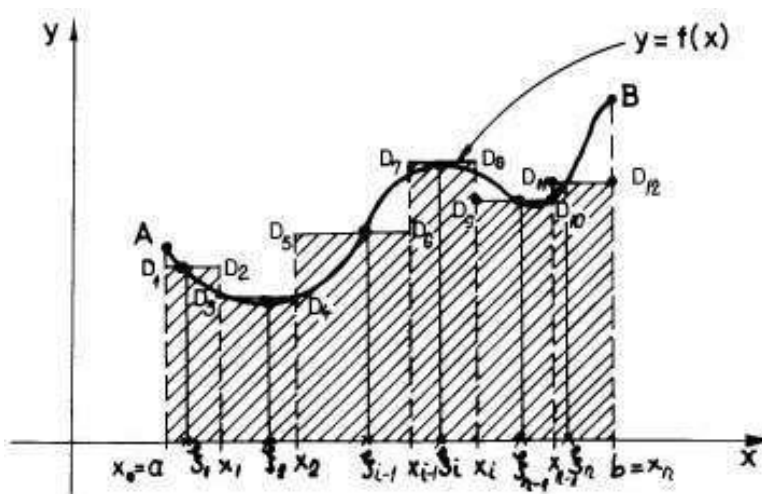

FIGURE 1.

Thus, these sums can well approximate the area of the trapezoid $aABb$ (see Fig.1) If the set of all these Riemann sums (when Δ and $\{\xi_i\}$ vary such that $\|\Delta\| \rightarrow 0$) have one and only one limit point $I(f)$, we say that this number $I(f)$ is exactly the mass of the bar (think of this intuitively!). Here it was an example which justify the following definition. We recall that a limit point for a nonempty subset A of \mathbb{R} is a point a of \mathbb{R} such that for any small real number $\varepsilon > 0$ the ε -neighborhood $(a - \varepsilon, a + \varepsilon)$ contains an infinite number of elements which are in A . For instance, $\{0\}$ is a limit point of the set $A = \{1, 1/2, 1/3, \dots, 1/n, \dots\}$.

DEFINITION 3. We say that a function $f : [a, b] \rightarrow \mathbb{R}$ is (Riemann) integrable on $[a, b]$ if there exist a real number $I(f)$, called the definite integral of f from a to b and denoted by $\int_a^b f(x)dx$, such that for any $\varepsilon > 0$ there is a $\delta_\varepsilon > 0$ with the following property: if Δ is a division of $[a, b]$ with $\|\Delta\| < \delta_\varepsilon$, then $|S(f; \Delta; \{\xi_i\}) - I(f)| < \varepsilon$ for any set of marking points $\{\xi_i\}$ of the division Δ .

The above defined number $I(f) = \int_a^b f(x)dx$ can be well approximated with Riemann sums of type (1.2). It is easy to see that such a number $I(f)$ is unique (do it!). The above definition says that if we look at a Riemann sum as a function of the division Δ and of $\{\xi_i\}$, a set of marking points of Δ , this last defined function "has a limit" as $\|\Delta\| \rightarrow 0$ if and only if f is Riemann integrable on $[a, b]$.

EXAMPLE 26. Let k be a constant number and let $f : [a, b] \rightarrow \mathbb{R}$ be the constant function: $f(x) = k$ for any $x \in [a, b]$. For a division $\Delta : a = x_0 < x_1 < x_2 < \dots < x_n = b$ and for a set of marking points $\{\xi_i\}$ of it, the corresponding Riemann sum is

$$S(f; \Delta; \{\xi_i\}) = \sum_{i=1}^n f(\xi_i)(x_i - x_{i-1}) = k \sum_{i=1}^n (x_i - x_{i-1}) = k(b - a),$$

thus all the Riemann sums are equal to the constant number $k(b - a)$, i.e. f is integrable on $[a, b]$ and its integral $I(f) = k(b - a)$.

Even for not complicated functions, to prove the integrability and to compute directly $I(f)$, usually is not an easy task.

EXAMPLE 27. For instance, let $f(x) = x$, $x \in [0, 1]$. Then

$$S(f; \Delta; \{\xi_i\}) = \sum_{i=1}^n f(\xi_i)(x_i - x_{i-1}) = \sum_{i=1}^n \xi_i(x_i - x_{i-1}).$$

Since $\xi_i \in [x_{i-1}, x_i]$, $i = 1, 2, \dots, n$, we can write

$$\begin{aligned} \sum_{i=1}^n \xi_i(x_i - x_{i-1}) &= \sum_{i=1}^n \left(\xi_i - \frac{x_i + x_{i-1}}{2} \right) (x_i - x_{i-1}) + \\ &+ \sum_{i=1}^n \frac{x_i + x_{i-1}}{2} (x_i - x_{i-1}) \end{aligned}$$

Since

$$\sum_{i=1}^n \frac{x_i + x_{i-1}}{2} (x_i - x_{i-1}) = \frac{1}{2}$$

and since for any fixed $\varepsilon > 0$ and for any division Δ with $\|\Delta\| < \varepsilon$

$$\left| \sum_{i=1}^n \left(\xi_i - \frac{x_i + x_{i-1}}{2} \right) (x_i - x_{i-1}) \right| < \varepsilon,$$

one sees that

$$\left| \sum_{i=1}^n \xi_i(x_i - x_{i-1}) - \frac{1}{2} \right| < \varepsilon$$

for any division Δ with $\|\Delta\| < \varepsilon$. This means (see the definition above) that $\int_0^1 x dx = \frac{1}{2}$.

The main problems we are concerned with are: 1) When a function $f : [a, b] \rightarrow \mathbb{R}$ is Riemann integrable? and 2) If f is integrable, how do we compute its definite integral $\int_a^b f(x) dx$? Let us begin with the following remark.

THEOREM 13. *Let $f : [a, b] \rightarrow \mathbb{R}$ be a Riemann integrable function. Then it is bounded, i.e. $\|f\| = \sup_{x \in [a, b]} |f(x)|$ is a finite number.*

PROOF. Let $I(f) = \int_a^b f(x)dx$ and let $\varepsilon > 0$ be a small number, $\varepsilon = 1/10$ for instance. Let $\Delta : a = x_0 < x_1 < x_2 < \dots < x_n = b$ be a division of $[a, b]$ such that

$$(1.3) \quad |I(f) - S(f; \Delta; \{\xi_i\})| < 1/10,$$

for any set of marking points $\{\xi_i\}$ of Δ . Suppose that f is unbounded to ∞ . Then f is unbounded at least on a subinterval $[x_{j-1}, x_j]$. Let us change the marking point ξ_j with $\xi_j^{(1)}, \xi_j^{(2)}, \dots, \xi_j^{(k)}, \dots$ such that $f(\xi_j^{(k)}) \rightarrow \infty$, when $k \rightarrow \infty$. But

$$S(f; \Delta; \{\xi_i\}) = \left[\sum_{i=1, i \neq j}^n f(\xi_i)(x_i - x_{i-1}) \right] + f(\xi_j^{(k)})(x_j - x_{j-1}) \rightarrow \infty,$$

which contradicts the inequality (1.3). Thus f must be bounded. \square

2. Darboux sums and their applications

DEFINITION 4. *Let $f : [a, b] \rightarrow \mathbb{R}$ be a bounded function and let $\Delta : a = x_0 < x_1 < x_2 < \dots < x_n = b$ be a division of $[a, b]$. Let $m = \inf_{x \in [a, b]} f(x)$, the least value of f on $[a, b]$, $M = \sup_{x \in [a, b]} f(x)$, the greatest value of f on $[a, b]$, $m_i = \inf_{x \in [x_{i-1}, x_i]} f(x)$, the least value of f on $[x_{i-1}, x_i]$ and $M_i = \sup_{x \in [x_{i-1}, x_i]} f(x)$, the greatest value of f on $[x_{i-1}, x_i]$, $i = 1, 2, \dots, n$. The following sums*

$$(2.1) \quad s_{\Delta}(f) = \sum_{i=1}^n m_i(x_i - x_{i-1}), \quad S_{\Delta}(f) = \sum_{i=1}^n M_i(x_i - x_{i-1})$$

are called the inferior and respectively the superior Darboux sums associated to function f and to division Δ .

Now, $s_{\Delta}(f)$ and $S_{\Delta}(f)$ can be interpreted as the sum of the hatched areas of rectangles in Fig.2 and respectively Fig.3.

It is clear enough that

$$(2.2) \quad m(b-a) \leq s_{\Delta} \leq S(f; \Delta; \{\xi_i\}) \leq S_{\Delta} \leq M(b-a),$$

for any set of marking points $\{\xi_i\}$, $\xi_i \in [x_{i-1}, x_i]$, $i = 1, 2, \dots, n$ (see also Fig.4).

Since the set of real numbers $\{s_{\Delta}\}$, when Δ runs on the set of all divisions of $[a, b]$, is upper bounded by $M(b-a)$ (see (2.2)), there

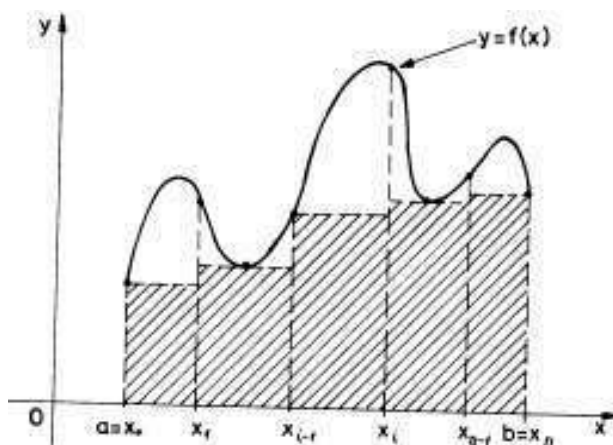

FIGURE 2.

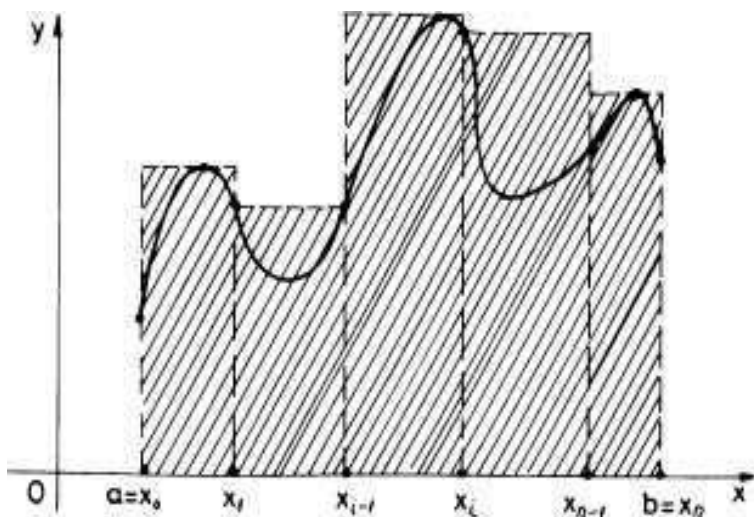

FIGURE 3.

is the least upper bound $I_*(f)$ of $\{s_\Delta\}$. This last number is called the *inferior Darboux integral* of f . Since the set of real numbers $\{S_\Delta\}$, when Δ runs on the set of all divisions of $[a, b]$, is lower bounded by $m(b-a)$ (see (2.2)), there is the greatest lower bound $I^*(f)$ of $\{S_\Delta\}$. This last number is called the *superior Darboux integral* of f . There are examples for which these two Darboux integrals are not equal. For instance, let $f : [a, b] \rightarrow \mathbb{R}$ be the mapping which associates to a rational number of $[a, b]$ the value 0 and to an irrational number of $[a, b]$ the value 1. Then, $I_*(f) = 0$ and $I^*(f) = 1$. To make things clearer, let us consider

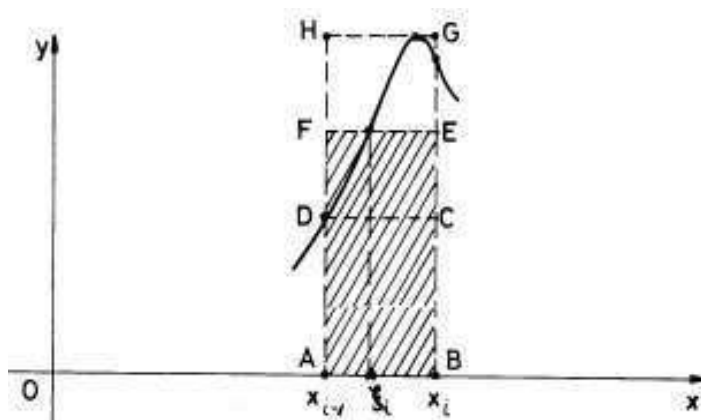

FIGURE 4.

two divisions Δ and Δ' of $[a, b]$ such that Δ' contains the points of Δ and maybe some additional other points. We write this as: $\Delta \prec \Delta'$. Adding successively to Δ only one point c at a time, we can easily prove (do it using a picture!-see Fig.5) that:

$$(2.3) \quad s_{\Delta} \leq s_{\Delta'} \leq S_{\Delta'} \leq S_{\Delta}.$$

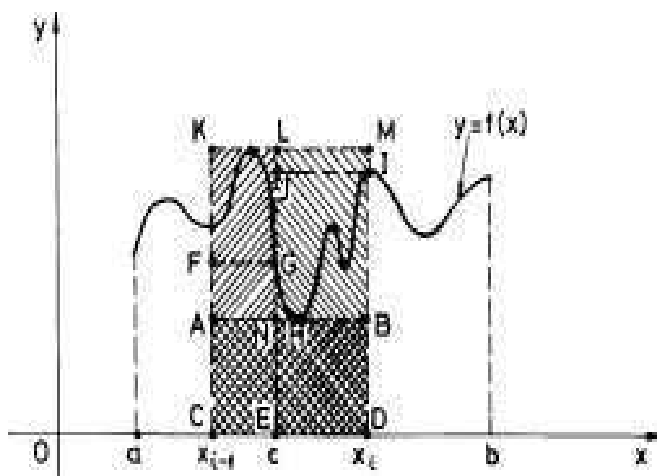

FIGURE 5

Taking now two arbitrary divisions Δ' and Δ'' of $[a, b]$, we can construct the "least" division $\Delta''' = \Delta' \cup \Delta''$ which contains Δ' and Δ'' at the same time: $\Delta' \prec \Delta'''$ and $\Delta'' \prec \Delta'''$. Thus (2.3) becomes:

$$s_{\Delta'} \leq s_{\Delta'''} \leq S_{\Delta'''} \leq S_{\Delta''},$$

so $s_{\Delta'} \leq S_{\Delta''}$ for any two arbitrary divisions Δ' and Δ'' of $[a, b]$. Thus the inequality $I_*(f) \leq I^*(f)$ is clear! Moreover, since $m_i = \inf_{x \in [x_{i-1}, x_i]} f(x)$, keeping the division Δ fixed, one can find a sequence $\{\xi_i^{(n)}\}$ of numbers in $[x_{i-1}, x_i]$ such that $f(\xi_i^{(n)}) \rightarrow m_i$ as $n \rightarrow \infty$. Thus, as close as we want to s_{Δ} one can find Riemann sums of the form $S(f; \Delta; \{\xi_i^{(n)}\})$ for a fixed Δ . The same is also true for S_{Δ} . Let us assume now that $f : [a, b] \rightarrow \mathbb{R}$ is Riemann integrable with $I(f) = \int_a^b f(x)dx$ and let $\varepsilon > 0$ be a small real number. Let $\delta_{\varepsilon} > 0$ be small enough such that if $\|\Delta\| < \delta_{\varepsilon}$ then

$$(2.4) \quad |I(f) - S(f; \Delta; \{\xi_i\})| < \frac{\varepsilon}{4}$$

for any marking points $\{\xi_i\}$ of the division Δ . Take now two sets of marking points $\{\xi'_i\}$ and $\{\xi''_i\}$ with the property that:

$$(2.5) \quad |S_{\Delta} - S(f; \Delta; \{\xi'_i\})| < \frac{\varepsilon}{4} \text{ and } |S(f; \Delta; \{\xi''_i\}) - s_{\Delta}| < \frac{\varepsilon}{4}.$$

So, one can write:

$$\begin{aligned} S_{\Delta} - s_{\Delta} &\leq |S_{\Delta} - S(f; \Delta; \{\xi'_i\})| + |S(f; \Delta; \{\xi'_i\}) - I(f)| + \\ &+ |I(f) - S(f; \Delta; \{\xi''_i\})| + |S(f; \Delta; \{\xi''_i\}) - s_{\Delta}| < \frac{\varepsilon}{4} + \frac{\varepsilon}{4} + \frac{\varepsilon}{4} + \frac{\varepsilon}{4} = \varepsilon. \end{aligned}$$

Thus $S_{\Delta} - s_{\Delta} < \varepsilon$ for any division Δ with $\|\Delta\| < \delta_{\varepsilon}$. We just proved an implication of the following basic result.

THEOREM 14. (*Darboux Criterion*) $f : [a, b] \rightarrow \mathbb{R}$ is Riemann integrable if and only if $I_*(f) = I^*(f)$, i.e. if and only if for any small real number $\varepsilon > 0$, there is another small real number $\delta_{\varepsilon} > 0$ such that if Δ is any division with $\|\Delta\| < \delta_{\varepsilon}$, one has that $S_{\Delta} - s_{\Delta} < \varepsilon$.

PROOF. It remains to prove the converse. We denote the common value $I_*(f) = I^*(f)$ by $I(f)$ and let us prove that $I(f)$ is the unique limit point of all the Riemann sums $S(f; \Delta; \{\xi_i\})$, when $\|\Delta\| \rightarrow 0$. Let again $\varepsilon > 0$ be a small real number and let $\delta_{\varepsilon} > 0$ be the corresponding small real number such that if Δ is any division with $\|\Delta\| < \delta_{\varepsilon}$, one has that $S_{\Delta} - s_{\Delta} < \varepsilon$. Since $s_{\Delta} \leq S(f; \Delta; \{\xi_i\}) \leq S_{\Delta}$ (see 2.2) and since $s_{\Delta} \leq I_*(f) = I^*(f) = I(f) \leq S_{\Delta}$ one obtains that

$$|S(f; \Delta; \{\xi_i\}) - I(f)| \leq S_{\Delta} - s_{\Delta} < \varepsilon$$

for any division Δ with $\|\Delta\| < \delta_{\varepsilon}$ and for any set of marking points (ξ_i) of Δ . \square

REMARK 11. (*Riemann Criterion*) It is not difficult to prove that $f : [a, b] \rightarrow \mathbb{R}$ is Riemann integrable if and only if there is a real number $I(f)$ such that for any sequence $\{\Delta_n\}$ of divisions of $[a, b]$ with

$\|\Delta_n\| \rightarrow 0$ as $n \rightarrow \infty$ and for any set of marking points $\{\xi_i^{(n)}\}$ of Δ_n , $n = 1, 2, \dots$, one has that $S(f; \Delta_n; \{\xi_i^{(n)}\}) \rightarrow I(f)$, when $n \rightarrow \infty$. Thus, if we know that f is integrable on $[a, b]$, we can use some special types of divisions, for instance the equidistant divisions, i.e. those divisions $\Delta_n : a = x_0 < x_1 < x_2 < \dots < x_n = b$ for which $x_i - x_{i-1} = \frac{b-a}{n}$ for any $i = 1, 2, \dots, n$. Here we see that $x_i = a + i\frac{b-a}{n}$ so, Δ_n depends only of n . If $n < m$, then $\Delta_n \prec \Delta_m$ and $\|\Delta_n\| = \frac{b-a}{n} \rightarrow 0$, when $n \rightarrow \infty$. Thus, one can find $I(f)$ as the limit of a sequence $\{S(f; \Delta_n; \{\xi_i^{(n)}\})\}$ for some particular values of the marking points. For instance, one can take $\xi_i^{(n)} = \frac{1}{2}(x_{i-1} + x_i) = a + \frac{2i-1}{2} \frac{b-a}{n}$ and the approximation:

$$(2.6) \quad \int_a^b f(x)dx \approx R(f; n) \stackrel{\text{def}}{=} S(f; \Delta_n; \{\xi_i^{(n)}\}) =$$

$$(2.7) \quad = \frac{b-a}{n} \sum_{i=1}^n f\left(a + \frac{2i-1}{2} \frac{b-a}{n}\right)$$

for n large enough, is called "the rectangle method" (explain why?, by drawing all...).

Darboux Criterion is analogous to Cauchy Criterion for numerical sequences. Since we usually cannot guess in advance the value of $\int_a^b f(x)dx$, or we cannot exactly compute it, at least we need to know if it exists. To prove its existence Darboux Criterion is needed. Then we can approximate it by different methods. One cannot approximate something on which we are not sure that it exists! Let us now apply it in some particular but basic situations.

THEOREM 15. *Let $f : [a, b] \rightarrow \mathbb{R}$ be a monotonous (increasing or decreasing) function. Then f is Riemann integrable on $[a, b]$.*

PROOF. Suppose that f is a decreasing function and that it is not a constant function (we saw that $\int_a^b kdx = k(b-a)$ in example 26). Let us use Darboux Criterion (see theorem 14). Since $M_i = f(x_{i-1})$ and $m_i = f(x_i)$ (f is decreasing) one has that

$$(2.8) \quad S_\Delta - s_\Delta = \sum_{i=1}^n [f(x_{i-1}) - f(x_i)](x_i - x_{i-1}) \leq$$

$$(2.9) \quad \|\Delta\| \sum_{i=1}^n [f(x_{i-1}) - f(x_i)] = \|\Delta\| (f(a) - f(b)).$$

For a small real number $\varepsilon > 0$ it is sufficient to take $\delta_\varepsilon = \frac{\varepsilon}{f(a)-f(b)}$. Here $f(a) \neq f(b)$ because f was supposed not to be a constant function.

Indeed, if $\|\Delta\| < \delta_\varepsilon = \frac{\varepsilon}{f(a)-f(b)}$, then in (2.8) we get: $S_\Delta - s_\Delta < \frac{\varepsilon}{f(a)-f(b)}(f(a) - f(b)) = \varepsilon$ and Darboux Criterion works. \square

THEOREM 16. *Let $f : [a, b] \rightarrow \mathbb{R}$ be a continuous function. Then f is Riemann integrable.*

PROOF. We again apply Darboux Criterion. Let $\varepsilon > 0$ be a small real number and let $\delta_\varepsilon > 0$ be another small real number (which depends on ε) such that if $|x' - x''| < \delta_\varepsilon$, one has that $|f(x') - f(x'')| < \frac{\varepsilon}{b-a}$ (f is uniformly continuous, see [Po], Th. 59). Let us take a division $\Delta : a = x_0 < x_1 < x_2 < \dots < x_n = b$ with $\|\Delta\| < \delta_\varepsilon$. Then $M_i - m_i = f(x'_i) - f(x''_i) < \frac{\varepsilon}{b-a}$ for $x'_i, x''_i \in [x_{i-1}, x_i]$, $i = 1, 2, \dots, n$ (see [Po], Th. 32). Hence,

$$\begin{aligned} S_\Delta - s_\Delta &= \sum_{i=1}^n (M_i - m_i)(x_i - x_{i-1}) < \\ &< \frac{\varepsilon}{b-a} (x_1 - a + x_2 - x_1 + x_3 - x_2 + \dots + b) = \varepsilon. \end{aligned}$$

i.e. f is Riemann integrable on $[a, b]$. \square

REMARK 12. *a) Let $f : [a, b] \rightarrow \mathbb{R}$ be such that f is continuous on $[a, b)$ and f has the limit $y_0 = \lim_{x \nearrow b, x \neq b} f(x)$ at b , $y_0 \neq f(b)$, i.e. f is not continuous at b . Let $\tilde{f} : [a, b] \rightarrow \mathbb{R}$,*

$$\tilde{f}(x) = \begin{cases} f(x), & x \in [a, b) \\ y_0, & x = b \end{cases}.$$

It is easy to see that the Riemann sums of f and of \tilde{f} respectively are the same with the only exception when $\xi_n = b$. In this last case, the contributions of this marking point to both sums are $f(b)(b - x_{n-1})$ and $y_0(b - x_{n-1})$ respectively. But, when $\|\Delta\| \rightarrow 0$, $b - x_{n-1} \rightarrow 0$, thus both integrals exists or not simultaneously and $\int_a^b f(x)dx = \int_a^b \tilde{f}(x)dx$. The same is true if f is not continuous at a , but it has finite side limit on the right at a . Moreover, if $c \in (a, b)$ and if f is continuous on $[a, c) \cup (c, b]$, but it is not continuous at c , but having finite side limits at c then, using extensions like above for $f|_{[a, c)}$ (f restricted to the interval $[a, c)$) and for $f|_{(c, b]}$ respectively, we obtain that both integrals $\int_a^c \tilde{f}(x)dx$ and $\int_c^b \tilde{f}(x)dx$ exist. Moreover, it is not difficult to see that $\int_a^b f(x)dx$ exists and

$$(2.10) \quad \int_a^b f(x)dx = \int_a^c \tilde{f}(x)dx + \int_c^b \tilde{f}(x)dx.$$

In particular, when f is continuous on $[a, b]$, then this last relation becomes:

$$(2.11) \quad \int_a^b f(x)dx = \int_a^c f(x)dx + \int_c^b f(x)dx.$$

Combining all these above observations, we can recursively prove that if $c_1, c_2, \dots, c_N, a \leq c_1 < c_2 < \dots < c_N \leq b$ are the unique N points of discontinuity for f at which side limits exist and are finite, then one has:

$$(2.12) \quad \int_a^b f(x)dx = \int_a^{c_1} \tilde{f}(x)dx + \int_{c_1}^{c_2} \tilde{f}(x)dx + \dots + \int_{c_N}^b \tilde{f}(x)dx.$$

Here we clearly put $\int_a^a f(x)dx = 0$ if such situation appears. The function \tilde{f} is the extension of f at the ends of the corresponding intervals by the values of the side limits of f . Moreover, it is easy to prove from here that two continuous (but a finite number of points eventually, at which they have finite side limits) functions f and g , which differs at most on a finite set of points in $[a, b]$, are or not simultaneously integrable and

$$(2.13) \quad \int_a^b f(x)dx = \int_a^b g(x)dx.$$

For instance,

$$g(x) = \begin{cases} x, & x \neq \frac{1}{2} \\ 0, & x = \frac{1}{2} \end{cases}, g: [0, 1] \rightarrow \mathbb{R},$$

is integrable and

$$\int_0^1 g(x)dx = \int_0^1 xdx = \frac{1}{2},$$

as we just proved in example 27. The morale is that if the function is bounded, we do not care with it at a finite number of points from $[a, b]$, when we are interested in the integration process of this function. For instance, if

$$f(x) = \begin{cases} 1, & x \in [0, 1) \\ 2 & x \in [1, 2] \end{cases}.$$

Since $\int_0^2 f(x)dx = \int_0^1 dx + \int_1^2 2dx = 1 + 2 = 3$, (see example 26) we do not care of the value of the function in its discontinuity point $x = 1$.

We can give a more general frame for all of the questions discussed above, by introducing a new basic notion.

3. Lebesgue criterion and its applications

DEFINITION 5. We say that a subset A of \mathbb{R} has Lebesgue measure (L -measure) zero (we write $L(A) = 0$) if it can be covered by a finite or a countable set of intervals $\{I_n\}$, $n = 1, 2, \dots$, with sum of their lengths $\sum_{n=1}^{\infty} l(I_n)$ as small as we want. This means that for any small real number $\varepsilon > 0$, there is a set (finite or countable) of intervals $\{I_n\}$ such that $A \subset \cup_{n=1}^{\infty} I_n$ and $\sum_{n=1}^{\infty} l(I_n) < \varepsilon$.

EXAMPLE 28. For instance, if $A = \{a\}$, a point, has the L -measure zero. Indeed, let $\varepsilon > 0$ be a small real number and let the interval $I = (a - \varepsilon/4, a + \varepsilon/4)$. Since $a \in I$ and $l(I) = \varepsilon/2 < \varepsilon$, we get that the Lebesgue measure of A is zero, i.e. $L(A) = 0$. It is easy to see that if B, C are two sets with $B \subset C$ and $L(C) = 0$, then $L(B) = 0$. Moreover, if A_1, A_2, \dots, A_t have Lebesgue measures zero, then $L(\cup_{i=1}^t A_i) = 0$ (prove it!). What happens if instead of a finite set of L -measure zero sets we have a countable set of L -measure zero sets? Is their union again a L -measure zero set?

DEFINITION 6. A mathematical object (a function for instance) has a property " \mathcal{P} " almost everywhere (a.e.) on a subset D of \mathbb{R} if the subset $A \subset D$ of all the points at which this property " \mathcal{P} " fails has Lebesgue measure $L(A) = 0$.

For instance, if D is a domain in \mathbb{R} , a function $f : D \rightarrow \mathbb{R}$ is a.e. continuous on D if the set A of discontinuity points of f has Lebesgue measure zero. For instance, if A is a finite set of points.

A famous criterion was proved by a French mathematician, Henri Lebesgue (1875-1941).

THEOREM 17. (*Lebesgue criterion*) Let $f : [a, b] \rightarrow \mathbb{R}$ be a function. Then f is Riemann integrable if and only if it is bounded and the subset A of $[a, b]$ of all the points at which f is discontinuous has the Lebesgue measure zero, i.e. if and only if it is bounded and a.e. continuous on $[a, b]$.

The proof of this result is very technical and it cannot be given here. One can find it for instance in [Nik], §12.10. We shall apply this basic theorem in order to prove some other properties of the definite integral.

THEOREM 18. Let $f : [a, b] \rightarrow \mathbb{R}$ be a bounded piecewise continuous function (it is continuous but a finite number of points at which it has finite sided limits). Then it is integrable.

PROOF. Using theorem 17 it is enough to see that a set of a finite number of points has Lebesgue measure zero. But this last comes easily from example 28. \square

THEOREM 19. *Let $f : [a, b] \rightarrow \mathbb{R}$ be a Riemann integrable function and let $g : [a, b] \rightarrow \mathbb{R}$ be a bounded function which is equal to f almost everywhere. Then g is also integrable and $\int_a^b f(x)dx = \int_a^b g(x)dx$. In particular, if f is equal to zero almost everywhere, then f is integrable and $\int_a^b f(x)dx = 0$.*

PROOF. Let A be the subset of $[a, b]$ on which f is not continuous, let B be the subset of $[a, b]$ on which g is not continuous and let C be the subset of those $x \in [a, b]$ at which $f(x) \neq g(x)$. We can see that the discontinuity points of g are contained in $A \cup C$ and the Lebesgue measure of this last union is zero (see example 28). So g is integrable (see theorem 17). To prove the second statement, it is enough to see that both real numbers $I = \int_a^b f(x)dx$ and $J = \int_a^b g(x)dx$ can be approximated by the same type of Riemann sums. In any ε -neighborhood of I we can find a number of the form (a Riemann sum):

$$S(f; \Delta; \{\xi_i\}) = \sum_{i=1}^n f(\xi_i)(x_i - x_{i-1}),$$

where we can choose ξ_i arbitrary in $[x_{i-1}, x_i]$. Since this last interval cannot have the Lebesgue measure equal to zero (why?), it cannot be contained in C , so there is at least a $\xi_i \in [x_{i-1}, x_i]$ such that $\xi_i \notin C$. Thus, $f(\xi_i) = g(\xi_i)$ and $S(f; \Delta; \{\xi_i\}) = S(g; \Delta; \{\xi_i\})$. If $\|\Delta\|$ is sufficiently small, $S(g; \Delta; \{\xi_i\})$ belongs to the ε -neighborhood of J . So the intersection $(I - \varepsilon, I + \varepsilon) \cap (J - \varepsilon, J + \varepsilon)$ is not empty for any $\varepsilon > 0$. Hence $I = J$. \square

THEOREM 20. *Let $f : [a, b] \rightarrow \mathbb{R}$ be a Riemann integrable function and let $|f| : [a, b] \rightarrow \mathbb{R}$ be the function defined by $|f|(x) = |f(x)|$ (the absolute value of f). Then $|f|$ is Riemann integrable and $\left| \int_a^b f(x)dx \right| \leq \int_a^b |f(x)| dx$.*

PROOF. Since f is Riemann integrable, then f is bounded (see theorem 13). So there is $M > 0$ such that $|f(x)| \leq M$ for any $x \in [a, b]$. But this also means that $|f|$ is bounded. Let x_0 be a continuity point of f . Then x_0 is a continuity point for $|f|$. Indeed, if $x_n \rightarrow x_0$, then $f(x_n) \rightarrow f(x_0)$ and, since $||f(x_n)| - |f(x_0)|| \leq |f(x_n) - f(x_0)|$ (prove it!), one has that $|f(x_n)| \rightarrow |f(x_0)|$, i.e. x_0 is also a continuity point for $|f|$. Hence, if z is a discontinuity point of $|f|$, it cannot be a continuity

point for f . Finally we get that the set A of the discontinuity points of $|f|$ is contained in the set B of the discontinuity points of f . Since f is Riemann integrable, the L-measure of B is zero. Thus the L-measure of A is also zero (see example 28).

Let now $\{\Delta_n\}$ be a sequence of divisions of $[a, b]$, $\Delta_n : a < x_1^{(n)} < x_2^{(n)} < \dots < x_{k_n}^{(n)} = b$, such that $\|\Delta_n\| \rightarrow 0$. Then $S(f; \Delta_n; \{\xi_i^{(n)}\}) \rightarrow I(f)$ and $S(|f|; \Delta_n; \{\xi_i^{(n)}\}) \rightarrow I(|f|)$. But

$$\begin{aligned} \left| S(f; \Delta_n; \{\xi_i^{(n)}\}) \right| &= \left| \sum_{i=1}^n f(\xi_i^{(n)})(x_i^{(n)} - x_{i-1}^{(n)}) \right| \leq \\ &\leq \sum_{i=1}^n \left| f(\xi_i^{(n)}) \right| (x_i^{(n)} - x_{i-1}^{(n)}) = S(|f|; \Delta_n; \{\xi_i^{(n)}\}). \end{aligned}$$

So $|I(f)| \leq I(|f|)$, i.e. $\left| \int_a^b f(x) dx \right| \leq \int_a^b |f(x)| dx$. \square

In the following we put together some basic properties of the Riemann integrable functions space $Int[a, b]$, defined on a fixed interval $[a, b]$.

THEOREM 21. *Let $Int[a, b]$ be the set of all Riemann integrable functions on $[a, b]$.*

a) Then $Int[a, b]$ is a vector subspace of the vector space of all functions defined on $[a, b]$. Moreover, if $f, g \in Int[a, b]$ and $\alpha, \beta \in \mathbb{R}$, then

$$(3.1) \quad \int_a^b [\alpha f(x) + \beta g(x)] dx = \alpha \int_a^b f(x) dx + \beta \int_a^b g(x) dx.$$

b) If $f, g \in Int[a, b]$ and $f(x) \leq g(x)$ for any $x \in [a, b]$, then $\int_a^b f(x) dx \leq \int_a^b g(x) dx$. In particular, if $f(x) \geq 0$, then $\int_a^b f(x) dx \geq 0$. In general, $\int_a^b f(x) dx$ may be zero but $f(x) \neq 0$ for at least one point x .

c) If $c \in (a, b)$ and if $f \in Int[a, c]$ and if $f \in Int[c, b]$, then $f \in Int[a, b]$ and

$$(3.2) \quad \int_a^b f(x) dx = \int_a^c f(x) dx + \int_c^b f(x) dx$$

If $[a, b] \cap [c, d] = \emptyset$, we define $\int_{[a, b] \cup [c, d]} f(x) dx = \int_a^b f(x) dx + \int_c^d f(x) dx$.

We also put $\int_a^a f(x) dx = 0$ and $\int_b^a f(x) dx = -\int_a^b f(x) dx$. With this notation, let l, m, n be three arbitrary real numbers in the interval $[a, b]$, then for $f : [a, b] \rightarrow \mathbb{R}$, integrable, one has:

$$(3.3) \quad \int_l^n f(x) dx = \int_l^m f(x) dx + \int_m^n f(x) dx$$

d) Let $g : [a, b] \rightarrow [0, \infty)$ be a continuous function such that $\int_a^b g(x)dx = 0$. Then $g(x) = 0$ for any x in $[a, b]$.

PROOF. a) Let z be a continuity point for f and for g , where $f, g \in \text{Int}[a, b]$ and let α, β be two arbitrary real numbers. Then we know that z is also a continuity point for $\alpha f + \beta g$, where $(\alpha f + \beta g)(x) = \alpha f(x) + \beta g(x)$ for any $x \in [a, b]$. Thus, the discontinuity set of points for $\alpha f + \beta g$ is a subset of the union of the set of discontinuity points of f and the set of discontinuity points of g . Since these last two sets have the L-measure zero, we see that the L-measure of the set of discontinuity points of $\alpha f + \beta g$ is also zero. Now, since f and g are bounded, it is easy to see that $\alpha f + \beta g$ is also bounded. Let us use now theorem 17 and find that $\alpha f + \beta g$ is integrable. Formula (3.1) is true for Riemann sums, so it is also true for their limits.

b) Let $\{\Delta_n\}$, $\Delta_n : a < x_1^{(n)} < x_2^{(n)} < \dots < x_{k_n}^{(n)} = b$, be a sequence of divisions with $\|\Delta_n\| \rightarrow 0$ and let $\xi_i^{(n)} \in [x_{i-1}^{(n)}, x_i^{(n)}]$, $i = 1, 2, \dots, k_n$, be a corresponding sequence of marking points of it. Since $f(x) \leq g(x)$ one has that

$$\begin{aligned} S(f; \Delta_n; \{\xi_i^{(n)}\}) &= \sum_{i=1}^n f(\xi_i^{(n)})(x_i^{(n)} - x_{i-1}^{(n)}) \leq \\ &\leq \sum_{i=1}^n g(\xi_i^{(n)})(x_i^{(n)} - x_{i-1}^{(n)}) = S(g; \Delta_n; \{\xi_i^{(n)}\}). \end{aligned}$$

Taking limits here when $n \rightarrow \infty$, we get that $\int_a^b f(x)dx \leq \int_a^b g(x)dx$.

c) Since the discontinuity set of f on $[a, b]$ is the union of the discontinuity sets of f on $[a, c]$ and of f on $[c, b]$ respectively, we see that the L-measure of the first one is zero, i.e. f is integrable on $[a, b]$, if it is integrable on $[a, c]$ and on $[c, b]$ respectively. Let $\{\Delta'_n\}$, $\Delta'_n : a < x_1'^{(n)} < x_2'^{(n)} < \dots < x_{k'_n}^{(n)} = c$, be a sequence of divisions of $[a, c]$, with $\|\Delta'_n\| \rightarrow 0$ and let $\xi_i'^{(n)} \in [x_{i-1}'^{(n)}, x_i'^{(n)}]$, $i = 1, 2, \dots, k'_n$, be a corresponding sequence of marking points of it. Let also $\{\Delta''_n\}$, $\Delta''_n : a < x_1''^{(n)} < x_2''^{(n)} < \dots < x_{k''_n}^{(n)} = c$, be a sequence of divisions of $[c, b]$, with $\|\Delta''_n\| \rightarrow 0$ and let $\xi_i''^{(n)} \in [x_{i-1}''^{(n)}, x_i''^{(n)}]$, $i = 1, 2, \dots, k''_n$, be a corresponding sequence of marking points of it. We see that $\Delta_n = \Delta'_n \cup \Delta''_n$ is a division of $[a, b]$ with $\{\xi_i^{(n)}\} = \{\xi_i'^{(n)}\} \cup \{\xi_i''^{(n)}\}$ as a corresponding set of marking points. Since $\|\Delta_n\| \rightarrow 0$, and because

$$S(f; \Delta_n; \{\xi_i^{(n)}\}) = S(f; \Delta'_n; \{\xi_i'^{(n)}\}) + S(f; \Delta''_n; \{\xi_i''^{(n)}\}),$$

one has that $\int_a^b f(x)dx = \int_a^c f(x)dx + \int_c^b f(x)dx$. Let us use now this last equality and the definition $\int_b^a f(x)dx = -\int_a^b f(x)dx$ for $a < b$, in

order to prove (3.3). Assume for instance that $m < n < l$. Then, from (3.2) we get:

$$\int_m^l f(x)dx = \int_m^n f(x)dx + \int_n^l f(x)dx.$$

So

$$\int_l^n f(x)dx = - \int_n^l f(x)dx = \int_m^n f(x)dx - \int_m^l f(x)dx,$$

or $\int_l^n f(x)dx = \int_l^m f(x)dx + \int_m^n f(x)dx$.

d) Assume that there is a $c \in [a, b]$ such that $g(c) > 0$ (if $g(x) < 0$, the reasoning is completely analogous). Since g is continuous, there is an entire interval $[c - \varepsilon, c + \varepsilon] \subset [a, b]$, $\varepsilon > 0$, such that $g(x) > 0$ for any $x \in [c - \varepsilon, c + \varepsilon]$ (see [P \circ], theorem 34). Moreover, there is a point $x_0 \in [c - \varepsilon, c + \varepsilon]$ with $g(x_0) = \inf_{x \in [c - \varepsilon, c + \varepsilon]} g(x)$ (see [P \circ], theorem 32).

Thus, $g(x_0) > 0$. But

$$\int_a^b g(x)dx = \int_a^{c-\varepsilon} g(x)dx + \int_{c-\varepsilon}^{c+\varepsilon} g(x)dx + \int_{c+\varepsilon}^b g(x)dx \geq 2\varepsilon \cdot g(x_0) > 0,$$

which contradicts the hypothesis. Hence, $g(x) = 0$ for any $x \in [a, b]$. \square

REMARK 13. We say that a number $r \in \mathbb{R}$ can be well approximated with elements from a given subset A (the "approximation set") of \mathbb{R} if for any small real number $\varepsilon > 0$ one can find an element a_ε of A such that $|r - a_\varepsilon| < \varepsilon$. For instance, any real number r can be well approximated with rational numbers (here A is \mathbb{Q} , the set of rational numbers). Let now $f : [a, b] \rightarrow \mathbb{R}$ be a Riemann integrable function. Then $I(f) = \int_a^b f(x)dx$ can be well approximated by an element of the set of all Riemann sums of the form $S(f; \Delta; \{\xi_i\})$ (see definition 3).

4. Mean theorem. Newton-Leibniz formula

In order to estimate a definite integral $\int_a^b f(x)dx$, sometimes we need "mean formulas". They are also useful to prove some basic results which appear in many branches of pure or applied mathematics.

THEOREM 22. (Mean formulas) Let $f : [a, b] \rightarrow \mathbb{R}$ be a continuous function and let $g : [a, b] \rightarrow [0, \infty)$ be a nonnegative and nonzero continuous function. Then there is a real number $\xi \in [a, b]$ such that

$$(4.1) \quad \int_a^b f(x)g(x)dx = f(\xi) \int_a^b g(x)dx.$$

In particular, if $g(x) = 1$ for any $x \in [a, b]$, we get the classical "mean formula":

$$(4.2) \quad \int_a^b f(x) dx = f(\xi)(b - a).$$

This last formula says that the trapezoidal area $[AabB]$ (see Fig. 6) is equal to the area of the rectangle with the base $[a, b]$ and the height equal to the ordinate of f at a point $\xi \in [a, b]$.

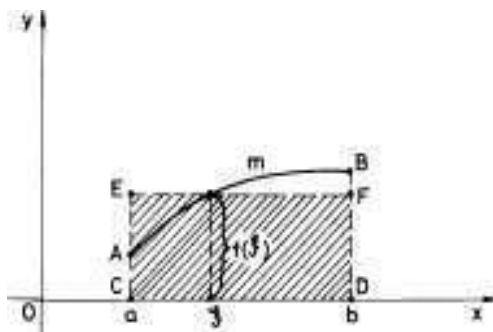

FIGURE 6

PROOF. Since f is continuous on $[a, b]$, it is bounded and its least and upper bounds are realized, i.e. there are x_1 and x_2 in $[a, b]$ such that $m = f(x_1) = \inf_{x \in [a, b]} f(x)$ and $M = f(x_2) = \sup_{x \in [a, b]} f(x)$ (see [Po],

Th. 32). Since $m \leq f(x) \leq M$ and $g(x) \geq 0$, one has that

$$mg(x) \leq f(x)g(x) \leq Mg(x),$$

for any $x \in [a, b]$. Let us use now theorem 21 and find:

$$m \int_a^b g(x) dx \leq \int_a^b f(x)g(x) dx \leq M \int_a^b g(x) dx.$$

Since $g(x)$ is continuous and not identical to zero, one has that

$$\int_a^b g(x) dx > 0$$

(see theorem 21), so we can divide the last inequalities by $\int_a^b g(x) dx$:

$$m \leq \frac{\int_a^b f(x)g(x) dx}{\int_a^b g(x) dx} \leq M.$$

We use now Darboux theorem (see [Po], Th. 33) for the function f ($f([a, b]) = [m, M]$) and find a $\xi \in [a, b]$ such that $\frac{\int_a^b f(x)g(x) dx}{\int_a^b g(x) dx} = f(\xi)$, i.e. formula (4.1). \square

EXAMPLE 29. Let us use the classical mean formula in order to prove that $I = \int_{10}^{100} e^{-x^2} dx < \frac{1}{293}$, so I is a very small number. Indeed, from formula (4.2) we find that $I = 90e^{-\xi^2}$, where $\xi \in [10, 100]$. But the biggest value of e^{-x^2} is $e^{-100} < 2^{-100}$, so $I < \frac{90}{2^{100}} < \frac{2^7}{2^{100}} = \frac{1}{2^{93}}$.

Let us now reformulate in a more general case the basic theorem of Newton (see theorem 1).

THEOREM 23. (Newton-Leibniz formula) Let $f : [a, b] \rightarrow \mathbb{R}$ be a continuous function. Then $F(x) = \int_a^x f(t) dt$ is a primitive for f , i.e. F is differentiable and $F'(x) = f(x)$ for any $x \in [a, b]$. Moreover, if $G(x)$ is any primitive of f on $[a, b]$, then

$$(4.3) \quad \int_a^b f(x) dx = G(b) - G(a).$$

PROOF. Take $x_0 \in [a, b]$ and let us study the following limit:

$$(4.4) \quad \lim_{x \rightarrow x_0} \frac{F(x) - F(x_0)}{x - x_0} = \lim_{x \rightarrow x_0} \frac{\int_a^x f(t) dt - \int_a^{x_0} f(t) dt}{x - x_0}.$$

But, using theorem 21, c), we get

$$\int_a^x f(t) dt - \int_a^{x_0} f(t) dt = \int_{x_0}^a f(t) dt + \int_a^x f(t) dt = \int_{x_0}^x f(t) dt,$$

so, applying the classical mean formula (4.2) in (4.4), we get

$$(4.5) \quad \lim_{x \rightarrow x_0} \frac{F(x) - F(x_0)}{x - x_0} = \lim_{x \rightarrow x_0} \frac{f(\xi_x)(x - x_0)}{x - x_0} = \lim_{x \rightarrow x_0} f(\xi_x).$$

Since ξ_x is between x and x_0 , then $\xi_x \rightarrow x_0$, whenever $x \rightarrow x_0$. Since f is continuous, the last limit in (4.5) is $f(x_0)$. Thus, we just proved that "the area function" F of Newton is a primitive of f on $[a, b]$.

Let now G be another primitive. Theorem 3 says that $G(x) = F(x) + C$, where C is a real constant. Thus,

$$G(b) - G(a) = F(b) - F(a) = \int_a^b f(x) dx.$$

\square

Newton-Leibniz formula (4.3) is true even for noncontinuous functions.

THEOREM 24. Let $f : [a, b] \rightarrow \mathbb{R}$ be an integrable function and let F be a primitive of f on $[a, b]$. Then $\int_a^b f(x) dx = F(b) - F(a)$.

PROOF. For any division $\Delta = \{a = x_0, x_1, \dots, x_n = b\}$ of the interval $[a, b]$ one has:

$$\sum_{i=1}^n [F(x_i) - F(x_{i-1})] = F(b) - F(a).$$

But, using the Lagrange formula (see [P \mathbf{o}], Ch.4, Cor.5) on the interval $[x_{i-1}, x_i]$, we find $c_i \in [x_{i-1}, x_i]$ such that $F(x_i) - F(x_{i-1}) = f(c_i)(x_i - x_{i-1})$. Thus,

$$\sum_{i=1}^n f(c_i)(x_i - x_{i-1}) = F(b) - F(a).$$

If we take divisions Δ with $\|\Delta\| \rightarrow 0$, we finally find that

$$\int_a^b f(x) dx = F(b) - F(a).$$

□

EXAMPLE 30. Let us compute $\int_0^1 x^2 dx$. To use Newton-Leibniz formula we need a primitive function for $f(x) = x^2$. Since $\int x^2 dx = \frac{x^3}{3}$, one has that $\int_0^1 x^2 dx = \frac{x^3}{3} \Big|_0^1 = \frac{1}{3} - \frac{0}{3} = \frac{1}{3}$.

EXAMPLE 31. Let us compute $\lim_{x \rightarrow 0} \frac{\int_0^x e^{-t^2} dt}{x}$. Since we have the indeterminate case $\frac{0}{0}$, we can apply l'Hôpital rule. But the function $G(x) = \int_0^x e^{-t^2} dt$ is a primitive of $g(x) = e^{-x^2}$ (see theorem 23). So $G'(x) = g(x)$ and our limit is equal to $\lim_{x \rightarrow 0} e^{-x^2} = 1$.

EXAMPLE 32. A point is moving on the segment $[0, \frac{\pi}{2}]$ in a linear field of forces $F(x) = x \sin x$. Find the work of F on $[0, \frac{\pi}{2}]$.

The work

$$\begin{aligned} W &= \int_0^{\frac{\pi}{2}} x \sin x dx = - \int_0^{\frac{\pi}{2}} x (\cos x)' dx \stackrel{\text{by parts}}{=} \\ &- x \cos x \Big|_0^{\frac{\pi}{2}} + \int_0^{\frac{\pi}{2}} \cos x dx = 0 + \sin x \Big|_0^{\frac{\pi}{2}} = 1. \end{aligned}$$

EXAMPLE 33. On the segment $[0, 2\pi]$ we have a density function $f(x) = \frac{1}{1 + \cos^2 x}$. Let us find the mass of the wire $([0, 2\pi], f(x))$. If we

change the variable x with a new variable t by the formula $\tan x = t$, we get :

$$\text{mass} = \int_0^{2\pi} \frac{1}{1 + \cos^2 x} dx = \int_0^0 \dots = 0 !,$$

which is not true! Where did we make a mistake? Since the mapping $x \rightarrow \tan x = t$ is not injective on $[0, 2\pi]$, it is not a "change of variable" on this last interval. The good interval for this change of variable is $(-\frac{\pi}{2}, \frac{\pi}{2})$. So let us make a translation $x \rightarrow x - \frac{\pi}{2} = z$ of the interval $[0, 2\pi]$:

$$(4.6) \quad \int_0^{2\pi} \frac{1}{1 + \cos^2 x} dx = \int_{-\frac{\pi}{2}}^{\frac{3\pi}{2}} \frac{1}{1 + \sin^2 z} dz,$$

because $\cos x = \cos(z + \frac{\pi}{2}) = -\cos(\pi - z - \frac{\pi}{2}) = -\sin z$. The last integral in (4.6) can be written

$$\int_{-\frac{\pi}{2}}^{\frac{3\pi}{2}} \frac{1}{1 + \sin^2 z} dz = \int_{-\frac{\pi}{2}}^{\frac{\pi}{2}} \frac{1}{1 + \sin^2 z} dz + \int_{\frac{\pi}{2}}^{\frac{3\pi}{2}} \frac{1}{1 + \sin^2 z} dz.$$

If in the last integral of the last sum of integrals we make the translation (change of variable) $z \rightarrow z - \pi = u$, we get

$$\int_{\frac{\pi}{2}}^{\frac{3\pi}{2}} \frac{1}{1 + \sin^2 z} dz = \int_{-\frac{\pi}{2}}^{\frac{\pi}{2}} \frac{1}{1 + \sin^2 u} du,$$

because $\sin z = \sin(\pi + u) = \sin(\pi - \pi - u) = -\sin u$. Thus

$$\int_{-\frac{\pi}{2}}^{\frac{3\pi}{2}} \frac{1}{1 + \sin^2 z} dz = 2 \int_{-\frac{\pi}{2}}^{\frac{\pi}{2}} \frac{1}{1 + \sin^2 z} dz = 4 \int_0^{\frac{\pi}{2}} \frac{1}{1 + \sin^2 z} dz.$$

In this last integral we can make the change of variable $\tan z = t$ and obtain:

$$\begin{aligned} 4 \int_0^{\frac{\pi}{2}} \frac{1}{1 + \sin^2 z} dz &= 4 \int_0^{\infty} \frac{1}{1 + 2t^2} dt = \\ \frac{4}{\sqrt{2}} \int_0^{\infty} \frac{1}{1 + (\sqrt{2}t)^2} d(\sqrt{2}t) &= \frac{4}{\sqrt{2}} \arctan \sqrt{2}t \Big|_0^{\infty} = \sqrt{2}\pi, \end{aligned}$$

because $\sin^2 z = \frac{t^2}{1+t^2}$, $z = \arctan t$ and $dz = \frac{1}{1+t^2} dt$ for $z \in [0, \frac{\pi}{2})$. Here

$$\int_0^{\infty} \frac{1}{1 + 2t^2} dt \stackrel{\text{def}}{=} \lim_{A \rightarrow \infty} \int_0^A \frac{1}{1 + 2t^2} dt,$$

i.e. it is a first example of an improper integral of the first type (see the next chapter).

5. The measure of a figure in \mathbb{R}^n

Recall that the n -dimensional real vector space \mathbb{R}^n is a "geometrical" space with the Euclidean distance

$$d(\mathbf{x}, \mathbf{y}) = \sqrt{(y_1 - x_1)^2 + (y_2 - x_2)^2 + \dots + (y_n - x_n)^2},$$

where $\mathbf{x} = (x_1, x_2, \dots, x_n)$ and $\mathbf{y} = (y_1, y_2, \dots, y_n)$ are two arbitrary elements of \mathbb{R}^n . An *open ball* with centre $\mathbf{a} \in \mathbb{R}^n$ and radius $r > 0$, in \mathbb{R}^n , is a subset $B(\mathbf{a}, r)$ of \mathbb{R}^n , of the following form:

$$B(\mathbf{a}, r) = \{\mathbf{x} \in \mathbb{R}^n : d(\mathbf{x}, \mathbf{a}) < r\}$$

A point \mathbf{a} of a subset A in \mathbb{R}^n is said to be an *interior point* of A (relative to \mathbb{R}^n) if there is a real number $r > 0$ such that the entire open ball $B(\mathbf{a}, r)$ is contained in A . If all the point of A are interior points we say that A is an *open subset* of \mathbb{R}^n . The *boundary* ∂A of a subset A of \mathbb{R}^n is the union of all the points \mathbf{b} in \mathbb{R}^n such that for any $r > 0$ the ball $B(\mathbf{b}, r)$ contains at least one point from A and at least one point from the outside of A at the same time. $A \cup \partial A$ is called the (*topological*) *closure* of A in \mathbb{R}^n . If $A = A \cup \partial A$, i.e. if the boundary ∂A of A is contained in A , we say that A is *closed*. We say that a subset A is *bounded* in \mathbb{R}^n if there is a sufficiently large open ball $B(\mathbf{0}, R)$ which contains A . Here $\mathbf{0} = (0, 0, \dots, 0) \in \mathbb{R}^n$. Let \mathbf{a} and \mathbf{b} be two points in \mathbb{R}^n and t a variable point (number) in the real interval $[0, 1]$. The closed subset of \mathbb{R}^n

$$[\mathbf{a}, \mathbf{b}] = \{\mathbf{x} \in \mathbb{R}^n : \mathbf{x} = (1 - t)\mathbf{a} + t\mathbf{b}, \text{ for a } t \in [0, 1]\}$$

is called an (*oriented*) *segment* in \mathbb{R}^n with extremities points \mathbf{a} and \mathbf{b} . A subset $P = \cup_{i=1}^{i=n} [\mathbf{a}_{i-1}, \mathbf{a}_i]$ of \mathbb{R}^n is said to be a *polygonal line* generated by the "vertices" $\mathbf{a}_0, \mathbf{a}_1, \dots, \mathbf{a}_n$. We also say that the points \mathbf{a}_0 and \mathbf{a}_n are *connected* by the polygonal line P . A subset A of \mathbb{R}^n is said to be *connected* if any two points of it can be connected by a polygonal line P . A *figure* B in \mathbb{R}^n is a bounded subset of \mathbb{R}^n . A *domain* in \mathbb{R}^n is an open and connected subset of \mathbb{R}^n . Since all these above notions just appeared and were discussed in [Po], we only ask the reader to try to find examples and counterexamples of all of these notions, by drawing everything, in \mathbb{R}^n for $n = 1, 2$, and 3.

DEFINITION 7. A subset A in \mathbb{R}^n of the form

$$A = [a_1, b_1] \times [a_2, b_2] \times \dots \times [a_n, b_n]$$

is said to be a *parallelepiped* in \mathbb{R}^n . A finite union $E = \cup_{i=1}^n A_i$ of parallelepipeds A_i , such that for any $i \neq j$ the intersection subset $A_i \cap A_j$ has no interior point in \mathbb{R}^n , is called an *elementary figure*. By

definition, the measure (or the volume) of the above parallelepiped A is the number

$$m(A) = (b_1 - a_1)(b_2 - a_2) \dots (b_n - a_n).$$

The measure $m(E)$ of the above elementary figure E is by definition

$$m(E) = \sum_{i=1}^n m(A_i).$$

We say that a subset B of \mathbb{R}^n is Jordan measurable (or has a volume) in \mathbb{R}^n and its measure (or its volume) is the nonnegative real number $m(B)$ if for any $\varepsilon > 0$ there are two elementary figures E_{int}^ε and E_{ext}^ε with the following properties:

- 1) $E_{int}^\varepsilon \subseteq B \subseteq E_{ext}^\varepsilon$
- 2) $m(E_{int}^\varepsilon) \leq m(B) \leq m(E_{ext}^\varepsilon)$ and
- 3) $m(E_{ext}^\varepsilon) - m(E_{int}^\varepsilon) < \varepsilon$.

These three properties say that B is measurable and its measure (volume) is the nonnegative real number $m(B)$ if and only if B can be well approximated (or covered) "from interior (inside)" and "from exterior (outside)" by two sequences $\{E_{int}^{(m)}\}_m$, $\{E_{ext}^{(m)}\}_m$ of elementary figures in \mathbb{R}^n :

$$(5.1) \quad E_{int}^{(1)} \subseteq E_{int}^{(2)} \subseteq \dots \subseteq E_{int}^{(p)} \subseteq \dots \subseteq B \subseteq$$

$$(5.2) \quad \dots \subseteq E_{ext}^{(q)} \subseteq \dots \subseteq E_{ext}^{(2)} \subseteq E_{ext}^{(1)},$$

such that

$$(5.3) \quad m(B) = \lim_{m \rightarrow \infty} m(E_{ext}^{(m)}) = \lim_{m \rightarrow \infty} m(E_{int}^{(m)}).$$

For instance, a parallelepiped in \mathbb{R} is a closed interval $[a, b]$. Two such intervals $[a, b]$ and $[c, d]$ have no interior points in common if and only if their intersection is empty or it is simply a point (Why cannot it contain two distinct points?). The measure (the length in this case) of an interval $[a, b]$ is exactly its length $b - a$. The measure of a finite subset of points in \mathbb{R} is equal to zero. But what about an infinite subset of points in \mathbb{R} ? For instance, let us prove that the set $C = \{\frac{1}{n}\}_n$ has measure zero in \mathbb{R} . Its enough to construct two sequences like in (5.1). We take for all $E_{int}^{(p)}$, $p = 1, 2, \dots$ the empty set \emptyset . For $E_{ext}^{(q)}$ we take the union

$$E_{ext}^{(q)} = \cup_{n=1}^{2^q} \left[\frac{1}{n} - \frac{1}{2^{(n+2)^q}}, \frac{1}{n} + \frac{1}{2^{(n+2)^q}} \right] \cup \left[0, \frac{1}{2^q + 1} \right]$$

It is easy to see that this union is a disjoint one, i.e. the intersection between any two distinct segments of this union is empty. Moreover, the length of $E_{ext}^{(q)}$ is equal to $\sum_{n=1}^{2^q} \frac{1}{2^{(n+2)^q-1}} + \frac{1}{2^q+1}$. Since $\frac{1}{2^{(n+2)^q-1}} \leq \frac{1}{2^{3^q}}$

one has that $m(E_{ext}^{(q)}) \leq \frac{1}{2^{3^q-q}} + \frac{1}{2^{q+1}} \rightarrow 0$, when $q \rightarrow \infty$. Hence the measure of C exists and it is equal to zero. An easy example of a nonmeasurable subset of \mathbb{R} is the set $F = [0, 1] \cap \mathbb{Q}$. Since F contains no interior points w.r.t. \mathbb{R} , it cannot contain a nontrivial interval. So, if F were measurable, its measure would be zero. But this is not true because we cannot construct a sequence $(E_{ext}^{(q)})_q$, where each $E_{ext}^{(q)}$ is a finite union of intervals, two of which having in common at most one point, $F \subset E_{ext}^{(q)}$ for each q and $m(E_{ext}^{(q)}) \rightarrow 0$, where $q \rightarrow \infty$. Indeed, in these conditions $[0, 1] \subset E_{ext}^{(q)}$ for all $q = 1, 2, \dots$, thus $m(E_{ext}^{(q)}) \geq 1$ and so the sequence $(E_{ext}^{(q)})_q$ cannot tend to 0. In the same manner one can prove that if a subset A is measurable in \mathbb{R} and has measure zero, then it cannot have interior points. Conversely, if it is measurable and has no interior points, then its measure must be zero (Why?). The measure of a measurable subset A of \mathbb{R} is simply called its *length*, $l(A)$. What is the connection between the notion of a subset of \mathbb{R} of Lebesgue measure zero (see Definition 5) and the notion of a subset of \mathbb{R} of measure zero? It is clear that a subset of \mathbb{R} of measure zero (it is enough to be measurable!) must be bounded. It is also clear that a subset of \mathbb{R} of measure zero has also the Lebesgue measure zero (look carefully to both definitions!). The set $\mathbb{N}^* = \{1, 2, \dots, n, \dots\}$ can be covered by the disjoint union

$$\bigcup_{n=1}^{\infty} \left[n - \frac{1}{2^{ns+1}}, n + \frac{1}{2^{ns+1}} \right]$$

for any $s \geq 1$. Since the sum of the lengths of all intervals of this union is

$$\sum_{n=1}^{\infty} \frac{1}{2^{ns}} = \frac{1}{2^s} \cdot \frac{1}{1 - \frac{1}{2^s}} = \frac{1}{2^s - 1}$$

and since $\frac{1}{2^s - 1} \rightarrow 0$, when $s \rightarrow \infty$, we see that the Lebesgue measure of \mathbb{N}^* is zero and it is not bounded, i.e. it cannot be measurable, in particular it cannot have the measure zero.

Another interesting example of a zero Jordan measure set of \mathbb{R} is the famous Cantor set. Take the interval $A_0 = [0, 1]$, divide it into 3 equal subintervals, get out the middle open subinterval $(1/3, 2/3)$ and obtain

$$A_1 = [0, 1/3] \cup [2/3, 1] \subset A_0.$$

Take now each of the both disjoint intervals of A_1 and proceed in the same way. We obtain

$$A_2 = [0, 1/3^2] \cup [2/3^2, 1/3] \cup [2/3, 7/3^2] \cup [8/3^2, 1] \subset A_1 \subset A_0.$$

We continue in this way and get a tower of subsets

$$A_0 \supset A_1 \supset \dots A_n \supset A_{n+1} \supset \dots$$

The intersection $C = \bigcap_{n=1}^{\infty} A_n$ is an infinite subset of $[0, 1]$. This subset is called a Cantor subset. Since $m(A_n) = \left(\frac{2}{3}\right)^n \rightarrow 0$, when $n \rightarrow \infty$, its measure is zero. In particular its Lebesgue measure is also zero.

A parallelepiped in \mathbb{R}^2 is simply a rectangular surface (let us abbreviate with "rectangle") with its sides parallel to the coordinates axes (see Fig.7). Its measure is equal to its area. Using the area of such a rectangle we can deduce formulas for the areas of a parallelogram, a triangle or even for a disc (as the limit of the areas of some regular polygons inscribed in the circumference of this disc). Look at Fig.7.

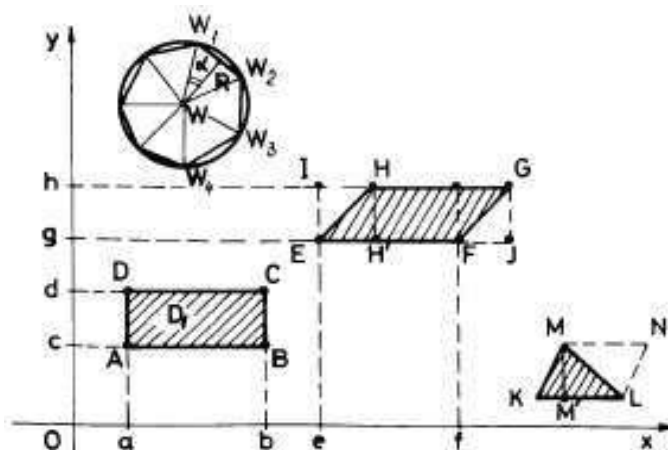

FIGURE 7

Indeed, the area of the parallelogram $[EFGH]$ is equal to the area of the rectangle $[HH'JG] = l(EF) \cdot l(HH')$. The area of the triangle $[KLM]$ is a half from the area of the parallelogram $[KLMN]$. To find the area of a disc with centre at W and of radius R , we approximate the disc with the surface bounded by a regular polygon with n sides inscribed in the boundary circle of this disc. Now, the angle α , in radians (see Fig.7), is equal to $\frac{2\pi}{2n} = \frac{\pi}{n}$. So the area of the polygon is equal to $n \cdot 2R \sin \frac{\pi}{n} \cdot R \cos \frac{\pi}{n} \cdot \frac{1}{2}$. Hence, the area of the disc is

$$\lim_{n \rightarrow \infty} R^2 \cos \frac{\pi}{n} \cdot \frac{\sin \frac{\pi}{n}}{\frac{\pi}{n}} \cdot \pi = \pi R^2.$$

The length of the boundary circle of the above disc is

$$\lim_{n \rightarrow \infty} n \cdot 2R \sin \frac{\pi}{n} = 2\pi R \lim_{n \rightarrow \infty} \frac{\sin \frac{\pi}{n}}{\frac{\pi}{n}} = 2\pi R.$$

EXERCISE 3. Starting with the formula for the area of a rectangle and of a triangle, find formulas for the side areas of a cylinder, of a cone and of a frustum of a cone ($\pi R^2 h$, $\pi R\sqrt{R^2 + h^2}$ and $\pi(R + r)\sqrt{(R - r)^2 + h^2}$), where h is the height of the corresponding solid)

The area of a region bounded by a closed polygonal line can be computed as a sum of areas of triangles (see Fig.8).

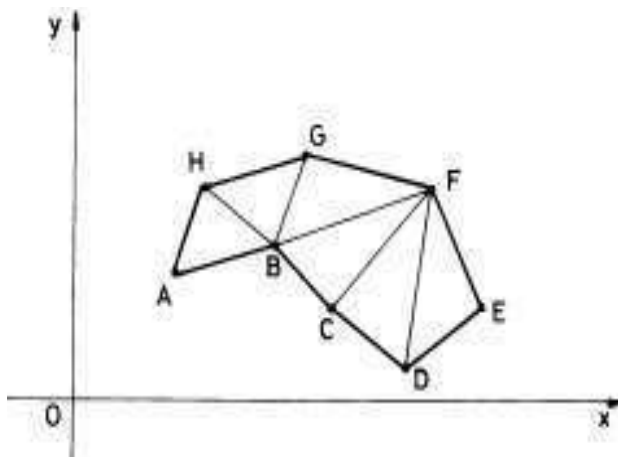

FIGURE 8

The intersection of two rectangles which belong to an elementary figure has no interior points w.r.t. \mathbb{R}^2 if and only if either it is empty, it is a point or a segment of a line parallel to one of the axes. For a plane elementary figure see Fig.9.

In Fig.10 we see how to cover "from interior" with an elementary figure a general plane figure A .

In Fig.11 we see how to cover "from exterior" with an elementary figure another general figure A .

In Fig.12 we see the simultaneous process of approximation "from interior" and "from exterior" with elementary figures \mathcal{E}_i and \mathcal{E}_o respectively, a general plane figure B .

The measure of a measurable figure A in \mathbb{R}^2 (a plane figure!) is simply called its *area* $\sigma(A)$. The areas of a finite union of points or of a finite union of segments of lines are zero (Why?). The same is true for a finite union of curves of class C^1 (*piecewise smooth curves!*).

REMARK 14. To define the area $\sigma(A)$ of a measurable subset A of \mathbb{R}^2 we used the above finite unions of rectangles as elementary figures. Since any rectangle is obvious a union of two triangles (as surfaces!) with their intersections a segment of zero areas and since any triangle

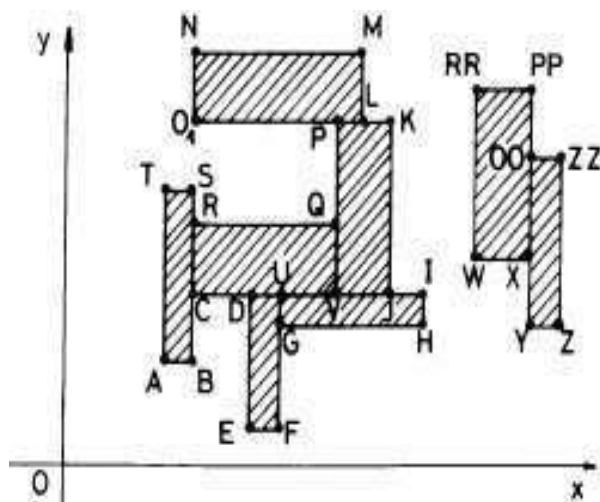

FIGURE 9

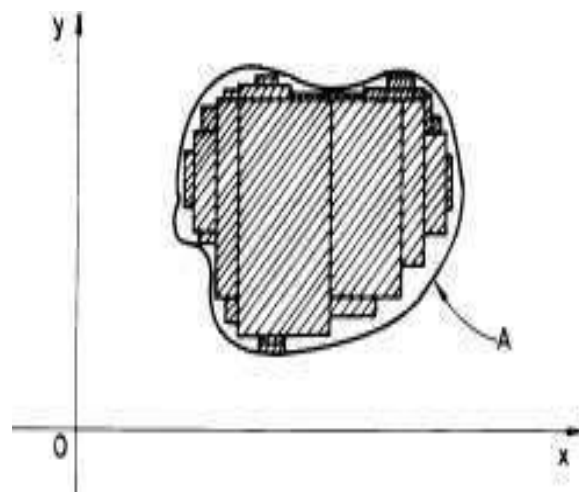

FIGURE 10

can be well covered by rectangles, we can use in definition 7 triangles instead of rectangles, namely an elementary figure can be a finite union of triangles. The same is true if instead of rectangles we use discs, or regular polygons, etc.

A parallelepiped in \mathbb{R}^3 is an usual parallelepiped $[a, b] \times [c, d] \times [e, f]$ which has its side faces parallel to the coordinate planes. The intersection between two such parallelepipeds contains no interior points w.r.t. \mathbb{R}^3 if and only if it is either empty, a point, a segment of a line or a rectangular surface parallel to one of the coordinates planes. The measure

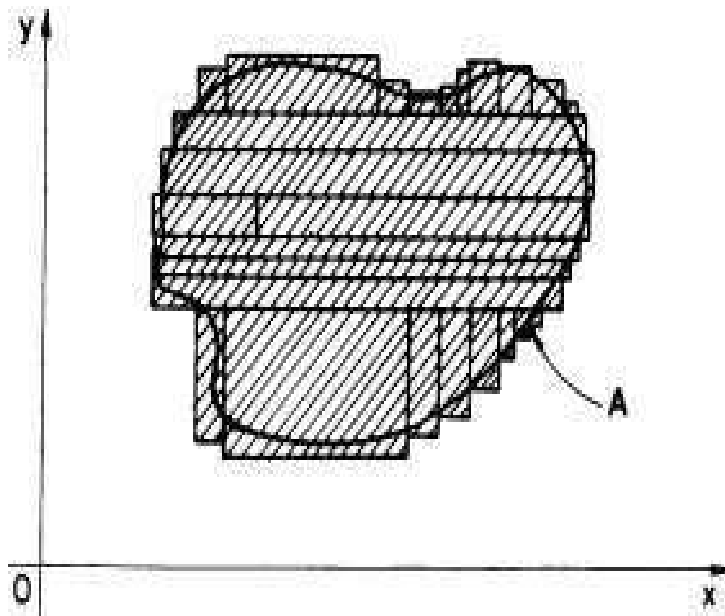

FIGURE 11

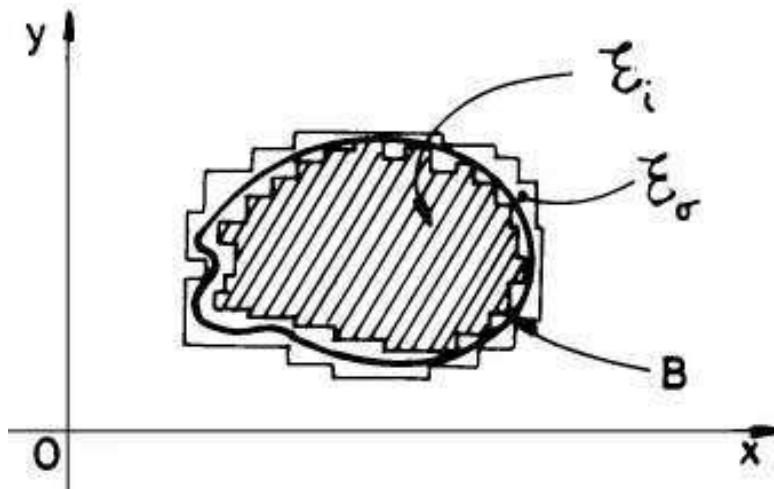

FIGURE 12

$vol(A)$ of a measurable subset A of \mathbb{R}^3 is simply called its *volume*. The volume of a finite set of points, a piecewise smooth curve or a piecewise smooth surfaces (define them by analogy with piecewise smooth curves) is zero. In this case we also can substitute parallelepipeds with tetrahedrons, balls, regular polyhedrons, etc.

EXERCISE 4. Starting with the formula of volume of a parallelepiped, find formulas to compute the volume of an arbitrary oblique parallelepiped, of a tetrahedron, a cylinder, a cone and a frustum of a cone (the area of the basis $\times h$, $\frac{1}{3} \times$ the area of the basis $\times h$, πR^2 (area of the basis) $\times h$, $\frac{1}{3} \times \pi R^2$ (area of the basis) $\times h$ and $\frac{\pi h}{3}(R^2 + r^2 + Rr)$), where h is the height of the corresponding solid).

It is not so difficult to see that if A, B are two measurable figure (C measurable $\Rightarrow C$ bounded) in \mathbb{R}^n , then $A \cup B$, $A \cap B$, $A \setminus B$ are also measurable and

$$(5.4) \quad m(A \cup B) = m(A) + m(B) - m(A \cap B).$$

We also see that if $A \subseteq B$ and both are measurable, then $m(A) \leq m(B)$. If a subset A of \mathbb{R} is measurable and its measure is zero, then its Lebesgue measure is also zero. Conversely, it is not true (see $A = \mathbb{N}$).

The following result is fundamental in what follows.

THEOREM 25. A figure A of \mathbb{R}^n is measurable if and only if its boundary is measurable and its measure is equal to zero. In particular, if one can find a piecewise smooth parameterization for the boundary ∂A of a figure A of \mathbb{R}^n , then A itself is measurable in \mathbb{R}^n .

For the case $n = 2$ one can find a proof in [Nik] or in [Pal]. In general, the proof follows a similar way. For an intuitive argument, see also Fig.12.

6. Areas of plane figures bounded by graphics of functions

Let $f : [a, b] \rightarrow \mathbb{R}_+$ be a bounded function defined on the interval $[a, b]$ with nonnegative values. Let D_f be the plane figure bounded by the lines $x = a, x = b$, the segment $[a, b]$ and the graphic of f (see the hatched figure $[ABCD]$ in Fig.1, Ch.1).

THEOREM 26. With the above notation f is Riemann integrable on $[a, b]$ if and only if the plane figure D_f has a measure (an area) in \mathbb{R}^2 and then

$$(6.1) \quad m(D_f) = \int_a^b f(x) dx.$$

PROOF. Assume that f is integrable on $[a, b]$. Then, for any division

$$\Delta : a = x_0 < x_1 < \dots < x_n = b,$$

the union of corresponding rectangles which give rise to the inferior Darboux sum

$$s_\Delta(f) = \sum_{i=1}^n m_i(x_i - x_{i-1})$$

is an elementary figure which covers D_f "from interior". Its area is $s_\Delta(f)$ (see Fig.8). The elementary figure generated by the union of all rectangles which appear in the superior Darboux sum

$$S_\Delta(f) = \sum_{i=1}^n M_i(x_i - x_{i-1})$$

covers D_f "from exterior". The area of this last figure is equal to $S_\Delta(f)$. The integrability Darboux criterion (see theorem 14) says that D_f is measurable and its area is the common limit of $\{s_\Delta(f)\}$ and $\{S_\Delta(f)\}$ when $\|\Delta\| \rightarrow 0$, i.e. $m(D_f) = \int_a^b f(x)dx$.

Assume now that D_f is measurable and its area is $m(D_f)$. Let us use now theorem 25 and, by looking at Fig.12, we see that for any $\varepsilon > 0$, starting with the elementary figures E_{int}^ε and E_{ext}^ε which appear in definition 7, we can find a division Δ_0 of the interval $[a, b]$ such that $S_{\Delta_0}(f) - s_{\Delta_0}(f) < \varepsilon$. For any other division $\Delta \succ \Delta_0$, let $E_{int}^{s_\Delta(f)}$ and $E_{ext}^{S_\Delta(f)}$ be the two elementary figures generated by the rectangles which give rise to the corresponding Darboux sums from the superior index. Then

$$(6.2) \quad E_{int}^\varepsilon \subset E_{int}^{s_\Delta(f)} \subset D_f \subset E_{ext}^{S_\Delta(f)} \subset E_{ext}^\varepsilon$$

and

$$(6.3) \quad m(E_{ext}^{S_\Delta(f)}) (= S_\Delta(f)) - m(E_{int}^{s_\Delta(f)}) (= s_\Delta(f)) < \varepsilon.$$

Taking now an arbitrary division Δ' of $[a, b]$ and denoting by $\Delta = \Delta' \cup \Delta_0$ we see that $\|\Delta\| \leq \|\Delta_0\|$ and $\Delta \succ \Delta_0$. So $S_\Delta(f) - s_\Delta(f) < \varepsilon$. By looking at (6.2) and (6.3) we see that $\{s_\Delta(f)\}$ and $\{S_\Delta(f)\}$ have a common limit when $\|\Delta\| \rightarrow 0$. And this last limit is $m(D_f)$. Hence f is integrable on $[a, b]$ and $\int_a^b f(x)dx = m(D_f)$. \square

REMARK 15. For instance, if $f(x) \geq 0$ is bounded and continuous on $[a, b]$ except maybe a finite number of points, then D_f is measurable and

$$\int_a^b f(x)dx = m(D_f).$$

EXAMPLE 34. Let $f(x) = \sin x$, $x \in [0, 2\pi]$. We are interested in the computation of the hatched area from Fig.13.

Applying the remark 15 we see that the area of the "+" part is equal to $\int_0^\pi \sin x dx = -\cos x \Big|_0^\pi = 2$. Now, if we take a division

$$\Delta : \pi = x_0 < x_1 < \dots < x_n = 2\pi$$

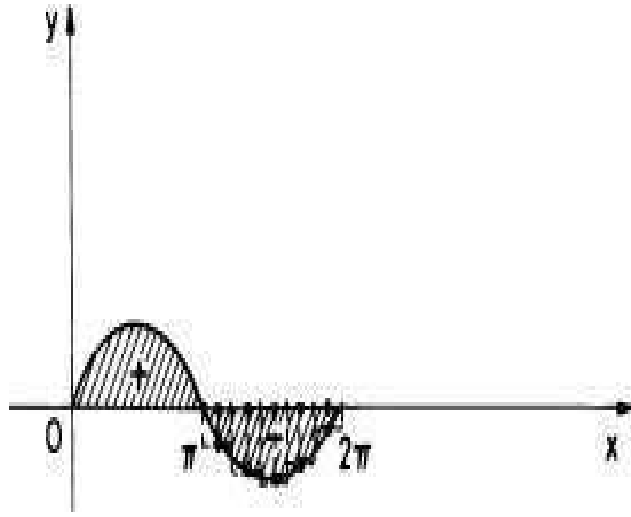

FIGURE 13

and a set of marking points $\{\xi_i\}_{i=1,n}$, $\xi_i \in [x_{i-1}, x_i]$, then the corresponding Riemann's sum

$$S_f(\Delta; \{\xi_i\}) = \sum_{i=1}^n f(\xi_i)(x_i - x_{i-1})$$

is negative, because $f(\xi_i) = \sin \xi_i \leq 0$. Thus the area (which is a non-negative number) is the limit of the following sums

$$\begin{aligned} -S_f(\Delta; \{\xi_i\}) &= -\sum_{i=1}^n f(\xi_i)(x_i - x_{i-1}) = \\ &\sum_{i=1}^n |f(\xi_i)|(x_i - x_{i-1}) = S_{|f|}(\Delta; \{\xi_i\}). \end{aligned}$$

Hence its value is $-\int_{\pi}^{2\pi} \sin x \, dx = \cos x \Big|_{\pi}^{2\pi} = 2$. Thus, the hatched area is equal to 4 and it is not equal to $\int_0^{2\pi} \sin x \, dx = 0$!

In general, if $f : [a, b] \rightarrow \mathbb{R}$ is continuous almost everywhere (the noncontinuity set of points A has the Lebesgue measure 0), then the area bounded by the graphic of f , $[a, b]$ and the lines $x = a$, $x = b$ is equal to the hatched area in Fig.14, i.e.

$$(6.4) \quad \text{area}(D_f) = \int_a^b |f(x)| \, dx,$$

in this more general case.

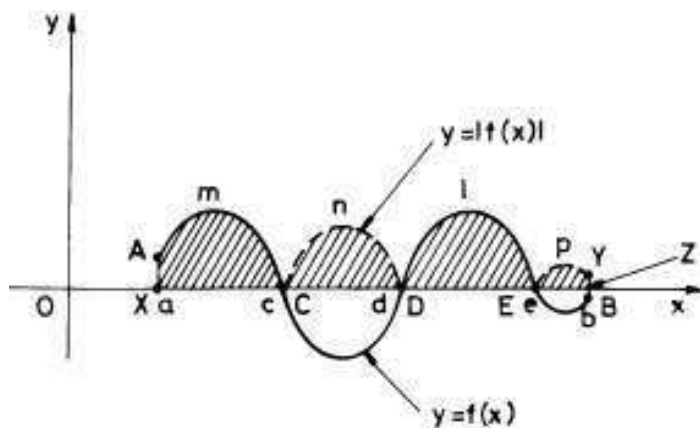

FIGURE 14

EXAMPLE 35. Let us compute $\text{area}(D_f)$ for $f : [-2, 1] \rightarrow \mathbb{R}$, where

$$f(x) = \begin{cases} x + 1, & x \in [-2, -1), \\ x^3, & x \in [-1, 1] \end{cases}.$$

Since

$$|f(x)| = \begin{cases} -x - 1, & x \in [-2, -1), \\ -x^3, & x \in [-1, 0), \\ x^3, & x \in [0, 1], \end{cases}$$

one has

$$\begin{aligned} \text{area}(D_f) &= \int_{-2}^1 |f(x)| dx = \int_{-2}^{-1} (-x - 1) dx + \\ &\quad \int_{-1}^0 (-x^3) dx + \int_0^1 x^3 dx \\ &= -\left(\frac{x^2}{2} + x\right) \Big|_{-2}^{-1} - \frac{x^4}{4} \Big|_{-1}^0 + \frac{x^4}{4} \Big|_0^1 \\ &= 1. \end{aligned}$$

Suppose that $f, g : [a, b] \rightarrow \mathbb{R}$ are two functions continuous almost everywhere and $f(x) \geq g(x)$ for any x in $[a, b]$. Then it is clear that the hatched area in Fig.15 is equal to

$$\int_a^b f(x) dx - \int_a^b g(x) dx = \int_a^b [f(x) - g(x)] dx.$$

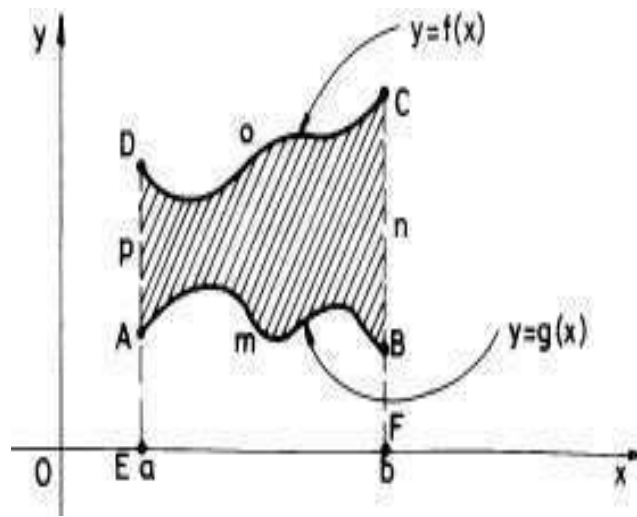

FIGURE 15

But whenever on a subinterval $[c, d] \subset [a, b]$, $g(x) \geq f(x)$, $x \in [c, d]$, we compute the area "between g and f " by the formula

$$\int_c^d [g(x) - f(x)] dx = \int_c^d |f(x) - g(x)| dx.$$

Thus, in general, the hatched area $area_{f,g}$ between f and g in Fig.16 can be computed by the formula

$$area_{f,g} = \int_a^b |f(x) - g(x)| dx.$$

Indeed,

$$\begin{aligned} area_{f,g} &= \int_a^c [g(x) - f(x)] dx + \int_c^d [f(x) - g(x)] dx + \\ &+ \int_d^e [g(x) - f(x)] dx + \int_e^b [f(x) - g(x)] dx = \int_a^b |f(x) - g(x)| dx. \end{aligned}$$

EXAMPLE 36. Let us compute the area between $f(x) = \sin x$ and $g(x) = \sin 2x$, $x \in [0, \pi]$. The best way is to look at the graphics of f and g in Fig.17.

Since the intersection points of these graphics are $x = 0$, $x = \frac{\pi}{3}$ and $x = \pi$, one can write:

$$area_{f,g} = \int_0^{\pi} |\sin x - \sin 2x| dx.$$

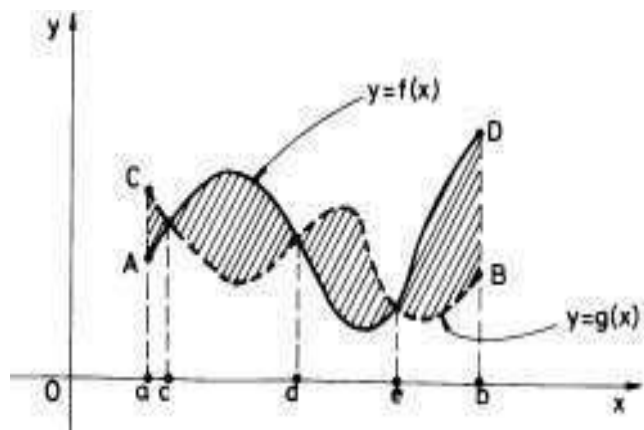

FIGURE 16

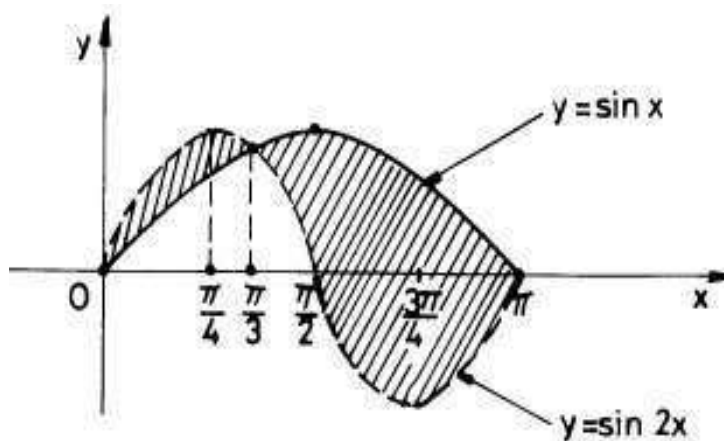

FIGURE 17

Since a continuous function keeps the same sign between two consecutive zeros of it (Why?-see Darboux theorem in [Po]), the sign of the function $h(x) = \sin x - \sin 2x$ is the sign of $h(\frac{\pi}{4}) = \frac{1}{\sqrt{2}} - 1 < 0$ on the interval $[0, \frac{\pi}{3}]$. The sign of $h(x)$ on the interval $[\frac{\pi}{3}, \pi]$ is the sign of $h(\frac{3\pi}{4}) = \frac{1}{\sqrt{2}} + 1 > 0$. Thus,

$$\begin{aligned} \text{area}_{f,g} &= \int_0^{\frac{\pi}{3}} (\sin 2x - \sin x) dx + \int_{\frac{\pi}{3}}^{\pi} (\sin x - \sin 2x) dx = \\ &= -\frac{\cos 2x}{2} \Big|_0^{\frac{\pi}{3}} + \cos x \Big|_0^{\frac{\pi}{3}} - \cos x \Big|_{\frac{\pi}{3}}^{\pi} + \frac{\cos 2x}{2} \Big|_{\frac{\pi}{3}}^{\pi} = \end{aligned}$$

$$\frac{1}{4} + \frac{1}{2} + \frac{1}{2} - 1 + 1 + \frac{1}{2} + \frac{1}{2} + \frac{1}{2} = \frac{11}{4}.$$

Assume now that we have a plane parametric curve

$$(\Gamma) : \begin{cases} x = x(t) \\ y = y(t) \end{cases}, \quad x \in [a, b],$$

such that $x(t)$ is an increasing function of class C^1 and $y(t)$ is a non-negative continuous function (see Fig.18).

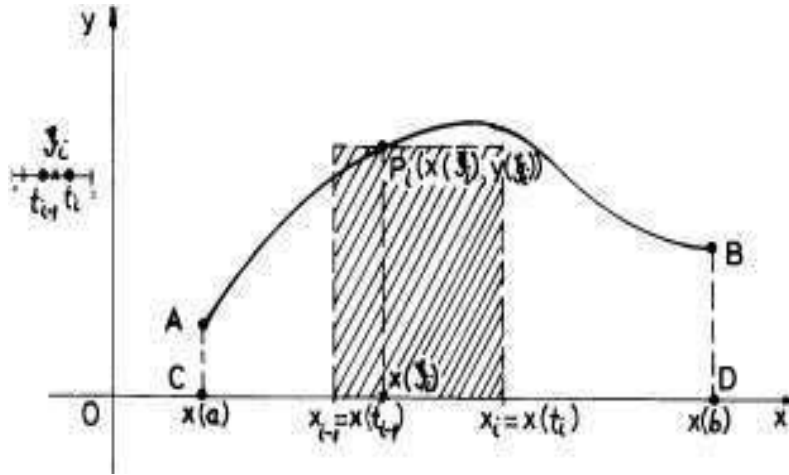

FIGURE 18

Then the area of the domain $D(\Gamma)$, bounded by (Γ) , the segment $[x(a), x(b)]$ and the lines $x = x(a)$, $x = x(b)$, can be approximated by Riemann's sums of the form:

$$(6.5) \quad S_{(\Gamma)}(\Delta; (\xi_i)) = \sum_{i=1}^n y(\xi_i) (x(t_i) - x(t_{i-1})),$$

where $\Delta : a = t_0 < t_1 < \dots < b = t_n$ is a division of the interval $[a, b]$ and (ξ_i) , $i = 1, 2, \dots, n$, ξ_i is an arbitrary set of fixed marking points for Δ . One can use Lagrange's formula for function $x(t)$ restricted to $[t_{i-1}, t_i]$ and find:

$$x(t_i) - x(t_{i-1}) = x'(\eta_i)(t_i - t_{i-1})$$

for an $\eta_i \in (t_{i-1}, t_i)$. When $\|\Delta\| \rightarrow 0$, η_i and ξ_i become closer and closer. Since $x'(t)$ is continuous, $x'(\eta_i)$ and $x'(\xi_i)$ become closer and closer. So the area above can be well approximated by sums of the form:

$$S_{(\Gamma)}^*(\Delta; (\xi_i)) = \sum_{i=1}^n y(\xi_i) x'(\xi_i) (t_i - t_{i-1}).$$

But these last sums are Riemann's sums for a new function $f(t) = y(t)x'(t)$, $t \in [a, b]$. Hence the area above can be computed by the formula

$$(6.6) \quad \text{area}(D(\Gamma)) = \int_a^b y(t)x'(t)dt.$$

If $x(t)$ is increasing or decreasing almost everywhere (it is increasing or decreasing on each subinterval of a fixed division $a = c_0 < c_1 < \dots < c_k = b$), then obviously formula (6.6) must be substituted with a more general formula

$$(6.7) \quad \text{area}(D(\Gamma)) = \int_a^b y(t)|x'(t)|dt.$$

The same formula works if in addition to this last generalization, $x(t)$ is a smooth piecewise function on $[a, b]$ and (or) $y(t)$ is piecewise continuous on the same interval.

EXAMPLE 37. *Let us compute the area bounded by the axis Ox and the arc of the cycloid*

$$(\Gamma) : \begin{cases} x = a(t - \sin t) \\ y = a(1 - \cos t) \end{cases}, \quad t \in [0, 2\pi],$$

where $a > 0$ is a parameter. Since $x'(t) = a(1 - \cos t) \geq 0$, we can apply formula (6.6) and find

$$\begin{aligned} \text{area} &= a^2 \int_0^{2\pi} (1 - \cos t)^2 dt = a^2 \int_0^{2\pi} (1 - 2\cos t + \cos^2 t) dt = \\ &= 2\pi a^2 + 0 + \frac{a^2}{2} \int_0^{2\pi} (1 + \cos 2t) dt = 3\pi a^2. \end{aligned}$$

Sometimes our curves are represented in polar coordinates $M(\rho, \theta)$, where ρ is the distance from O to M and θ is the angle in radians between Ox -axis and \overrightarrow{OM} . So $\rho \geq 0$ and θ can be in general any real number. For any fixed θ in a fixed interval $[\alpha, \beta]$, we give $\rho = \rho(\theta)$, i.e. we prescribe the distance from M to O on the positive direction of the half axis corresponding to that θ . Let us compute the area bounded by the graphic of a continuous (or piecewise continuous) mapping $\theta \rightarrow \rho(\theta)$, $\theta \in [\alpha, \beta]$ and the rays $\theta = \alpha, \theta = \beta$ (see Fig.19).

Let us consider a division $\Delta : \alpha = \theta_0 < \theta_1 < \dots < \theta_n = \beta$ of the interval $[\alpha, \beta]$ and an arbitrary set $\{\xi_i\}, \xi_i \in [\theta_{i-1}, \theta_i]$ of marking points for Δ . Let us approximate the small area bounded by the arc $(\theta_{i-1}\theta_i)$ and the rays $\theta = \theta_{i-1}$ and $\theta = \theta_i$ by the area of the sector

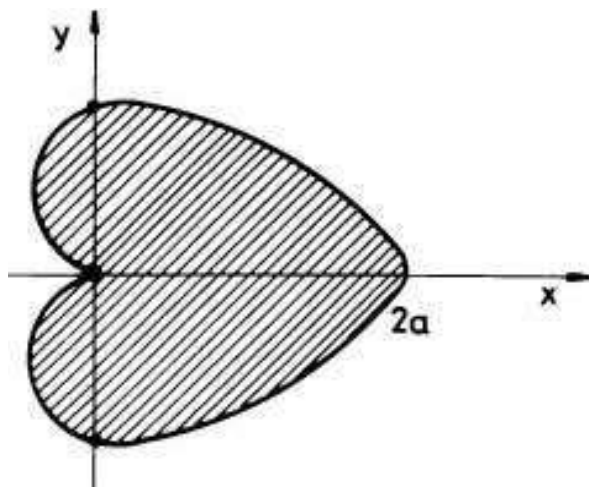

FIGURE 20

Since the ray \overrightarrow{OM} , $M(\rho(\theta), \theta)$ covers the double hatched region I two times the area of the hatched region is:

$$\text{area} = \frac{1}{2} \int_0^{\frac{5\pi}{2}} 9\theta^2 d\theta - \frac{1}{2} \int_0^{\frac{\pi}{2}} 9\theta^2 d\theta = \frac{93\pi^3}{4}.$$

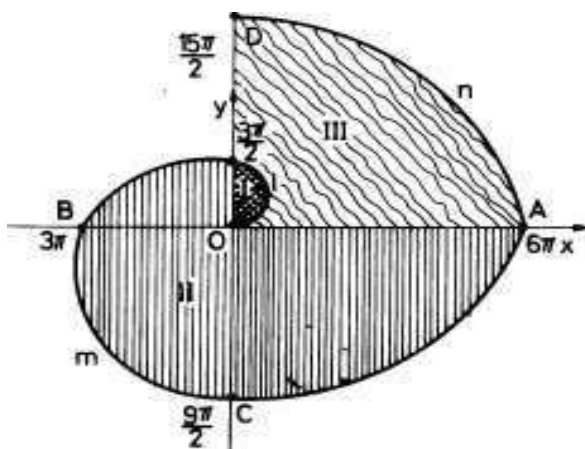

FIGURE 21

EXAMPLE 40. The graphic of the curve $\rho = \rho(\theta) = a \sin 3\theta$, where $\theta \in [0, 2\pi]$ has the form of a clover with three leaflets (see Fig.22). Since $\sin 3\theta$ must be greater or equal to zero, we have that

$$\theta \in [0, \frac{\pi}{3}] \cup [\frac{2\pi}{3}, \pi] \cup [\frac{4\pi}{3}, \frac{5\pi}{3}].$$

Compute the area of the hatched region in Fig.22. The symmetry of the figure with respect to the three distinct lines (see Fig.22) gives rise to

$$\text{area} = 3 \cdot \frac{1}{2} \int_0^{\frac{\pi}{3}} a^2 \sin^2 3\theta \, d\theta = \frac{\pi a^2}{4}.$$

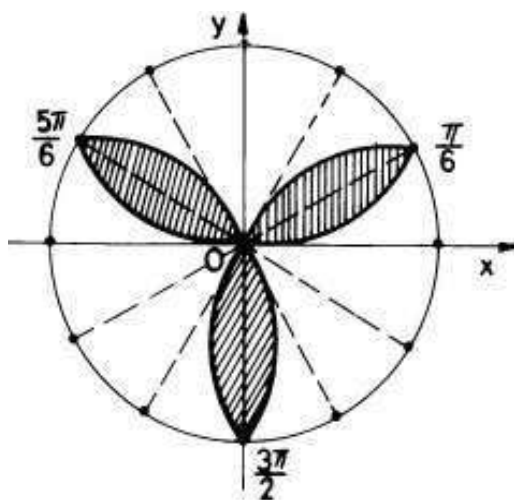

FIGURE 22

7. The volume of a rotational solid

Let $f : [a, b] \rightarrow \mathbb{R}_+$ be a continuous function defined on the interval $[a, b]$ with nonnegative real values. Let D be the solid obtained by the rotation of the arc $y = f(x)$, $x \in [a, b]$, around Ox -axis. An arbitrary division $\Delta : a = x_0 < x_1 < \dots < x_n = b$ gives rise to a division of D into n solids D_1, D_2, \dots, D_n . D_i can be obtained by the rotation of the same arc $y = f(x)$, but restricted to the interval $[x_{i-1}, x_i]$. We can well approximate this arc $y = f(x)$, $x \in [x_{i-1}, x_i]$ with the segment $[M_{i-1}M_i]$, where $M_{i-1}(x_{i-1}, f(x_{i-1}))$ and $M_i(x_i, f(x_i))$. So the solid D_i can be approximated by a frustum of a cone with $r = f(x_{i-1})$, $R = f(x_i)$ and $h = x_i - x_{i-1}$. (look at Fig.23 and make the same reasoning for cylinders instead of frustums).

Using now a formula from the exercise 4 we find that

$$\text{vol}(D_i) \approx \frac{\pi}{3}(x_i - x_{i-1}) [f(x_{i-1})^2 + f(x_i)^2 + f(x_{i-1})f(x_i)].$$

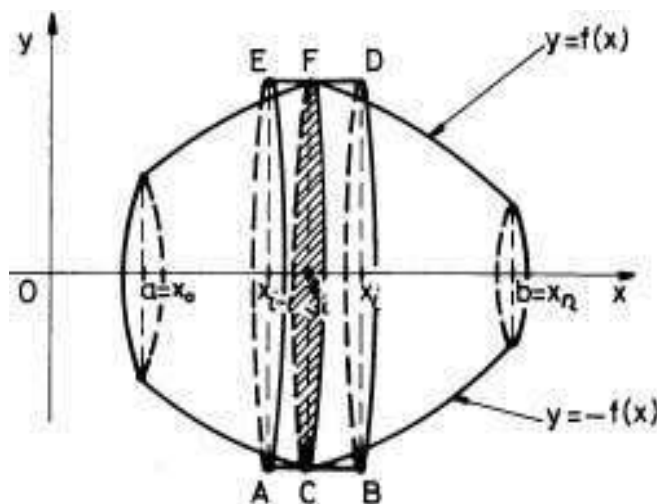

FIGURE 23

Hence,

$$(7.1) \quad \text{vol}(D) \approx \frac{\pi}{3} \sum_{i=1}^n [f(x_{i-1})^2 + f(x_i)^2 + f(x_{i-1})f(x_i)] (x_i - x_{i-1}).$$

Let us fix now a set of marking points $(\xi_i)_i$, $\xi_i \in [x_{i-1}, x_i]$, $i = 1, 2, \dots, n$. Since f is continuous, if the norm $\|\Delta\|$ of the division Δ is smaller and smaller, then $f(x_i)$ and $f(x_{i-1})$ are closer and closer to $f(\xi_i)$. Thus formula 7.1 becomes

$$(7.2) \quad \text{vol}(D) \approx \pi \sum_{i=1}^n f(\xi_i)^2 (x_i - x_{i-1}) = S_{\pi f^2}(\Delta; (\xi_i)),$$

a Riemann sum for the function πf^2 , the division Δ and the set of marking points (ξ_i) . So

$$(7.3) \quad \text{vol}(D) = \pi \int_a^b f^2(x) dx.$$

Formula (7.2) says that we can well approximate the volume of the rotational solid D with the sum of volumes of the cylinders C_i , generated by the rotation of the line $y(x) = f(\xi_i)$ for any $x \in [x_{i-1}, x_i]$, around Ox -axis (see Fig.24).

EXAMPLE 41. Let us find the volume of a ball of radius $R > 0$, in \mathbb{R}^3 .

Such a ball is the rotational solid generated by the rotation of the arc $y = \sqrt{R^2 - x^2}$, $x \in [-R, R]$ of the circle of radius R , $x^2 + y^2 = R^2$,

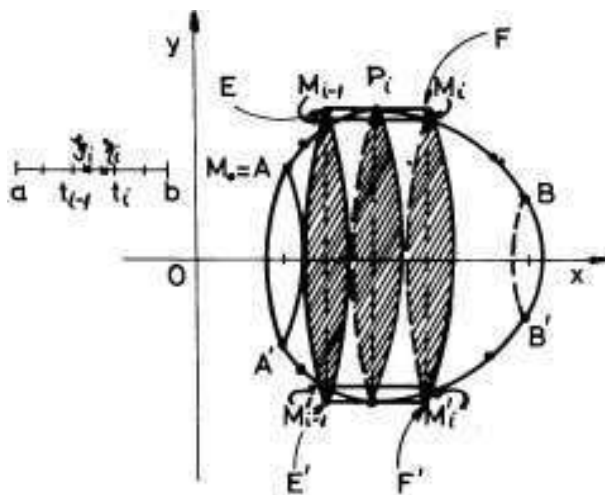

FIGURE 24

around Ox -axis. Thus,

$$\begin{aligned} \text{vol} &= \pi \int_{-R}^R (R^2 - x^2) dx = 2\pi \int_0^R (R^2 - x^2) dx = \\ &= 2\pi \left(R^2 x - \frac{x^3}{3} \right) \Big|_0^R = \frac{4\pi R^3}{3}. \end{aligned}$$

8. The length of a curve in \mathbb{R}^3

Let (Γ) be a curve in \mathbb{R}^3 represented by the parametric path

$$(8.1) \quad (\Gamma) : \begin{cases} x = x(t) \\ y = y(t) \\ z = z(t) \end{cases}, \quad t \in [a, b].$$

Let $\Delta : a = t_0 < t_1 < \dots < t_n = b$ be a division of the interval $[a, b]$ and let $M_i(x(t_i), y(t_i), z(t_i))$, $i = 0, 1, \dots, n$, be the corresponding division on (Γ) , i.e. the image through the vector mapping $\vec{r}(t) = (x(t), y(t), z(t))$, $t \in [a, b]$, (the deformation mapping of the segment $[a, b]$ onto the curve (Γ) as a subset of \mathbb{R}^3) of the division Δ . Let $l(\Delta)$ be the length of the polygonal line $[M_0 M_1 \dots M_n]$.

DEFINITION 8. We say that the curve (Γ) is rectifiable if there exists a nonnegative real number $l(\Gamma)$, such that for any $\varepsilon > 0$, there exists $\delta_\varepsilon > 0$ with the following property: if Δ is a division of the interval $[a, b]$, $\|\Delta\| < \delta_\varepsilon$, then $|l(\Delta) - l(\Gamma)| < \varepsilon$. This nonnegative real number $l(\Gamma)$ is called the length of (Γ) and it can be well approximated by lengths of polygonal lines of the form $[M_0 M_1 \dots M_n]$ (described above).

It is not difficult to prove that the property to be rectifiable does not depend on the parametric representation of (Γ) . The same is true for the length of (Γ) . This number $l(\Gamma)$ defined above is unique. Let us estimate now $l(\Gamma)$.

Let us consider a parametric representation of a smooth curve (Γ) (see (8.1)), a division $\Delta : a = t_0 < t_1 < \dots < t_n = b$ of the interval $[a, b]$ and a set of marking points $(\xi_i)_i$, $\xi_i \in [t_{i-1}, t_i]$ for any $i = 1, 2, \dots, n$. By definition 8 we can approximate the length $l(\Gamma)$ with

$$(8.2) \quad S = \sum_{i=1}^n \left\| \overrightarrow{M_{i-1}M_i} \right\| =$$

$$= \sum_{i=1}^n \sqrt{[x(t_i) - x(t_{i-1})]^2 + [y(t_i) - y(t_{i-1})]^2 + [z(t_i) - z(t_{i-1})]^2}.$$

(see Fig. 25).

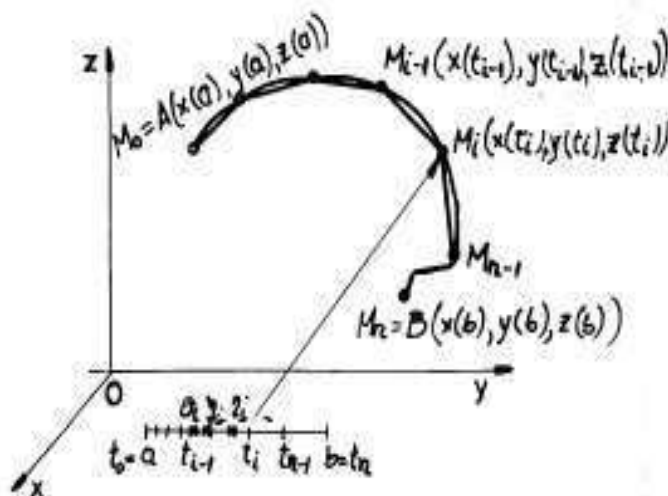

FIGURE 25

Since $x(t)$, $y(t)$ and $z(t)$ are of class C^1 , applying Lagrange formula to them on each interval $[t_{i-1}, t_i]$, we get

$$x(t_i) - x(t_{i-1}) = x'(\xi_i)(t_i - t_{i-1}) \approx x'(\xi_i)(t_i - t_{i-1}),$$

$$y(t_i) - y(t_{i-1}) = y'(\xi_i)(t_i - t_{i-1}) \approx y'(\xi_i)(t_i - t_{i-1}),$$

$$z(t_i) - z(t_{i-1}) = z'(\xi_i)(t_i - t_{i-1}) \approx z'(\xi_i)(t_i - t_{i-1}),$$

where $a_i, b_i, c_i \in [t_{i-1}, t_i]$ for each $i = 1, 2, \dots, n$. Thus, S can be well approximated (when $\|\Delta\| \rightarrow 0$) with

$$S_1 = \sum_{i=1}^n \sqrt{x'(\xi_i)^2 + y'(\xi_i)^2 + z'(\xi_i)^2} (t_i - t_{i-1}).$$

Indeed, since the function

$$H(u, v, w) = \sqrt{x'(u)^2 + y'(v)^2 + z'(w)^2},$$

$u, v, w \in [a, b] \times [a, b] \times [a, b]$ is uniformly continuous, then for any $\varepsilon > 0$, there exists $\delta_\varepsilon > 0$ such that

$$|H(u', v', w') - H(u'', v'', w'')| < \frac{\varepsilon}{b-a}$$

if

$$|u' - u''|, |v' - v''|, |w' - w''| < \delta_\varepsilon$$

. Thus, if $\|\Delta\| < \delta_\varepsilon$ one has that

$$\begin{aligned} |S - S_1| &\leq \sum_{i=1}^n |H(a_i, b_i, c_i) - H(\xi_i, \xi_i, \xi_i)| (t_i - t_{i-1}) \leq \\ &\leq \frac{\varepsilon}{b-a} \cdot (b-a) = \varepsilon. \end{aligned}$$

But this sum S_1 is a Riemann sum for the function

$$f(t) = \sqrt{x'(t)^2 + y'(t)^2 + z'(t)^2}.$$

So our curve (Γ) is rectifiable and its length can be computed by using the formula

$$(8.3) \quad l(\Gamma) = \int_a^b \sqrt{x'(t)^2 + y'(t)^2 + z'(t)^2} dt.$$

The expression $ds = \sqrt{x'(t)^2 + y'(t)^2 + z'(t)^2} dt$ is called the element of length on the arc Γ , i.e. it is "the limit" of the length of the arc $\widehat{M_{i-1}M_i}$ on Γ , when the distance between $M_{i-1}M_i$ is small enough.

Let us compute the length of the astroide

$$\begin{cases} x = a \cos^3 t \\ y = a \sin^3 t \end{cases}, t \in [0, 2\pi], a > 0$$

This curve is a plane curve, so $z(t) = 0$ in the above formula. We see that the Cartesian form of the parametric equation of the astroide is $x^{\frac{2}{3}} + y^{\frac{2}{3}} = a^{\frac{2}{3}}$. Thus the curve is symmetric relative to Ox and Oy axes. Hence its length is

$$\begin{aligned}
 l &= 4 \int_0^{\frac{\pi}{2}} \sqrt{9a^2 \cos^4 t \sin^2 t + 9a^2 \sin^4 t \cos^2 t} dt = 12a \int_0^{\frac{\pi}{2}} \sqrt{\cos^2 t \sin^2 t} dt = \\
 &= 12a \int_0^{\frac{\pi}{2}} |\cos t \sin t| dt = 6a \int_0^{\frac{\pi}{2}} \sin 2t dt = -3a \cos 2t \Big|_0^{\frac{\pi}{2}} = 6a.
 \end{aligned}$$

EXAMPLE 42. Let $M(x)$ be a moving point on the segment $[a, b]$ in a field of forces \vec{f} parallel to the Ox -axis oriented like the direct orientation of $[a, b]$, i.e. "from a to b ". (see Fig.26)

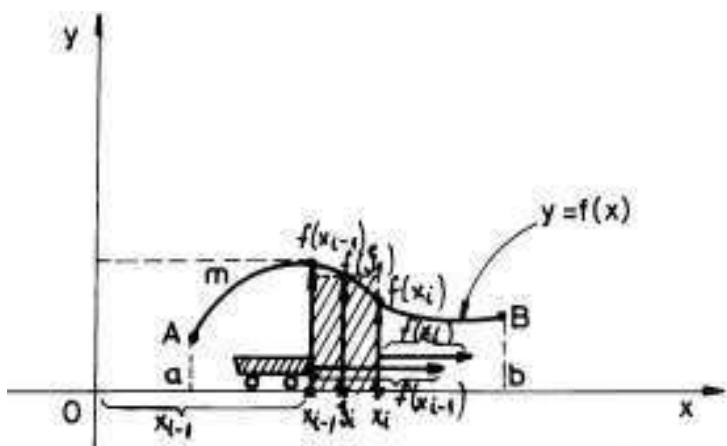

FIGURE 26

Let the norm (modulus) of this field be a continuous function $f(x)$, $x \in [a, b]$. If

$$\Delta : a = x_0 < x_1 < x_2 < \dots < x_n = b$$

is an arbitrary division of $[a, b]$ and $\{\xi_i\}$ is a set of marking points of it, then we can well approximate the work of \vec{f} along the oriented segment $[x_{i-1}, x_i]$ with $f(\xi_i)(x_i - x_{i-1})$. Thus, the work of \vec{f} along $[a, b]$ can be well approximated with the Riemann sum $S(f; \Delta; \{\xi_i\}) = \sum_{i=1}^n f(\xi_i)(x_i - x_{i-1})$. If the function f is integrable, then the work $W_{[a,b]} \vec{f}$ of \vec{f} along the segment $[a, b]$ is just $\int_a^b f(x) dx$.

9. Approximate computation of definite integrals.

Let $f : [a, b] \rightarrow \mathbb{R}$ be an integrable function. The definition itself of the notion of integrability (see Definition 3) is equivalent to the fact

that we can well approximate the number $I = \int_a^b f(x)dx$ with Riemann sums of the form

$$S_f(\Delta; \{\xi_i\}) = \sum_{i=1}^n f(\xi_i)(x_i - x_{i-1}),$$

where $\Delta : a = x_0 < x_1 < \dots < x_n = b$ is a division of $[a, b]$ with $\|\Delta\|$ small enough and $\{\xi_i\}$ is an arbitrary set of marking points, $\xi_i \in [x_{i-1}, x_i]$ for any $i = 1, 2, \dots, n$. Let us take a particular type of divisions, namely *equidistant divisions*. Let n be large enough and let $h = \frac{b-a}{n}$, "the increment" of the division

$$\Delta_n = a = x_0 < a + h = x_1 < \dots < a + ih = x_i < \dots < x_n = a + nh = b.$$

This division is an example of an equidistant division because $x_i - x_{i-1} = h$, a constant number. Let us take $\xi_i = \frac{x_{i-1} + x_i}{2}$, the midpoint of the interval $[x_{i-1}, x_i]$. Thus,

$$\xi_i = \frac{a + (i - 1)h + a + ih}{2} = a + \frac{2i - 1}{2}h.$$

So we can use in practice the following approximation:

$$(9.1) \quad \int_a^b f(x)dx \approx R(f; n) = \frac{b - a}{n} \sum_{i=1}^n f\left(a + \frac{2i - 1}{2}h\right).$$

This formula is called the *rectangles formula*. In Fig.27 the integral $\int_a^b f(x)dx$ is just the area of the plane surface bounded by the graphic of $f(x)$, when $x \in [a, b]$, the Ox -axis and the vertical lines $x = a, y = b$. The approximate $R(f; n)$ from formula (9.1) is exactly the hatched area of Fig.27, i.e. the sum of the areas of all the rectangles D_i , where D_i has as a basis the segment $[x_{i-1}, x_i]$ and as height $f(\xi_i)$, ξ_i being the midpoint of $[x_{i-1}, x_i]$.

We can also be interested in the error $err = |I - R(f; n)|$. If our function is integrable, this error becomes smaller and smaller, when $n \rightarrow \infty$.

EXAMPLE 43. Let us use the rectangles formula to evaluate the definite integral $I = \int_0^1 e^{-x^2} dx$. Higher Mathematics show that function $f(x) = e^{-x^2}$ has not any primitive which could expressed by elementary functions. For an approximate computation, take $n = 5$; then $\xi_1 = \frac{x_0 + x_1}{2} = 0.1$, $\xi_2 = \frac{x_1 + x_2}{2} = 0.3$, $\xi_3 = \frac{x_2 + x_3}{2} = 0.5$, $\xi_4 = \frac{x_3 + x_4}{2} = 0.7$ and $\xi_5 = 0.9$. So,

$$(9.2) \quad I \approx \frac{1}{5}[\exp(-0.01) + \exp(-0.09) + \exp(-0.25) +$$

$$(9.3) \quad + \exp(-0.49) + \exp(-0.81)].$$

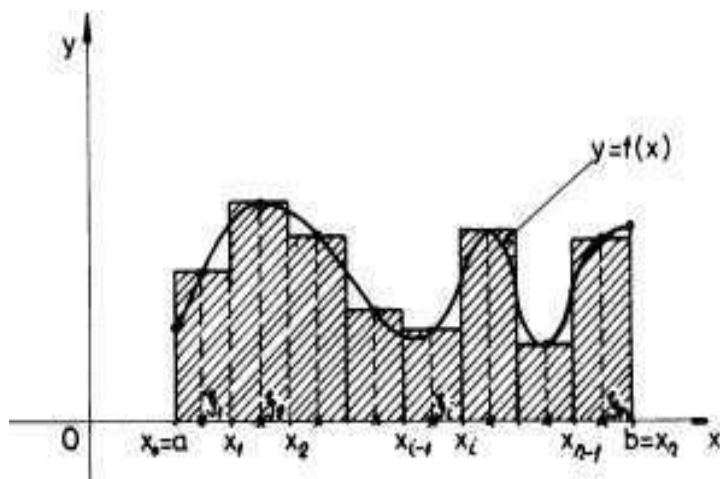

FIGURE 27

But what about the error we just have made in this last approximation?

Let us evaluate the error in the case of rectangles formula (9.1), when f is a function of class C^2 on $[a, b]$.

For this, we fix an $i \in \{1, 2, \dots, n\}$ and we try to estimate the error err_i made by substituting $\int_{x_{i-1}}^{x_i} f(x)dx$ with the area $f\left(\frac{x_{i-1}+x_i}{2}\right)(x_i - x_{i-1})$ of the rectangle which has the basis the segment $[x_{i-1}, x_i]$ and the height $f(c_i)$, where $c_i = \frac{x_{i-1}+x_i}{2}$ is the midpoint of this last segment (see Fig.28).

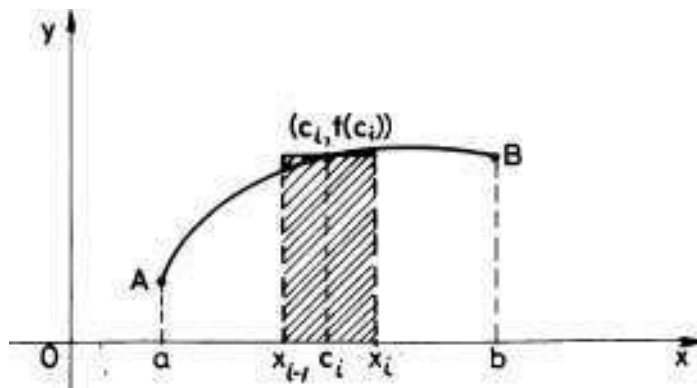

FIGURE 28

Let us denote by $M_2 = \sup_{x \in [a, b]} |f''(x)|$ and let us apply Taylor formula of order 2 around the point c_i , i.e.

$$(9.4) \quad f(x) = f(c_i) + \frac{f'(c_i)}{1!}(x - c_i) + \frac{f''(c_i)}{2!}(x - c_i)^2,$$

where c_i is a point in the interval $[x_{i-1}, x_i]$. Thus,

$$\begin{aligned} err_i &= \left| \int_{x_{i-1}}^{x_i} f(x) dx - f\left(\frac{x_{i-1} + x_i}{2}\right)(x_i - x_{i-1}) \right| = \\ &= \left| \int_{x_{i-1}}^{x_i} [f(x) - f(c_i)] dx \right| \leq \frac{|f'(c_i)|}{1!} \left| \int_{x_{i-1}}^{x_i} (x - c_i) dx \right| + \\ &+ \frac{M_2}{2} \left| \int_{x_{i-1}}^{x_i} (x - c_i)^2 dx \right| = 0 + \frac{M_2}{2} \left[\frac{(x_i - c_i)^3}{3} - \frac{(x_{i-1} - c_i)^3}{3} \right] = \\ &= \frac{M_2}{2} \left[\frac{(x_i - \frac{x_{i-1} + x_i}{2})^3}{3} - \frac{(x_{i-1} - \frac{x_{i-1} + x_i}{2})^3}{3} \right] = M_2 \frac{h^3}{24} = \frac{M_2}{24n^3} (b - a)^3. \end{aligned}$$

The global error

$$\begin{aligned} err &= \left| I - \sum_{i=1}^n f(c_i)(x_i - x_{i-1}) \right| = \left| \sum_{i=1}^n \int_{x_{i-1}}^{x_i} (f(x) - f(c_i)) dx \right| \leq \\ &\leq \sum_{i=1}^n err_i \leq n \cdot \frac{M_2}{24n^3} (b - a)^3 = \frac{M_2}{24n^2} (b - a)^3. \end{aligned}$$

Thus

$$(9.5) \quad err \leq \frac{M_2}{24n^2} (b - a)^3,$$

where $M_2 = \sup_{x \in [a, b]} |f''(x)|$.

Let us come back to example 43 and evaluate the error we have made by approximating $I = \int_0^1 e^{-x^2} dx$ with $R(e^{-x^2}; 5)$. Let us evaluate M_2 :

$$f'(x) = -2xe^{-x^2}; f''(x) = (-2 + 4x^2)e^{-x^2}.$$

Thus, $|f''(x)| \leq 2$ when $x \in [0, 1]$ and

$$err \leq \frac{2}{24 \cdot 25} \cdot 1^3 = \frac{1}{300} < \frac{1}{100}.$$

Hence, the sum from (9.2) approximates our integral with at least 2 exact decimals.

The general idea above is to substitute the original function $f : [a, b] \rightarrow \mathbb{R}$ with another one, called an *interpolating function*, usually

more elementary than the initial one. In our case of rectangles approximation, we substituted f with \tilde{f} such that $\tilde{f}(x) = f(c_i)$ for any $x \in [x_{i-1}, x_i]$, $i = 1, 2, \dots, n$. Then we approximated $I = \int_0^1 e^{-x^2} dx$ with

$$\int_a^b \tilde{f}(x) dx = \sum_{i=1}^n \int_{x_{i-1}}^{x_i} f(c_i) dx = \sum_{i=1}^n f(c_i)(x_i - x_{i-1}) = R(f, n).$$

In (9.1) we interpolated the function $f(x)$, $x \in [x_{i-1}, x_i]$ with a polynomial of degree 0, which has the same value as our function at the point $c_i = \frac{x_{i-1} + x_i}{2}$, the midpoint of $[x_{i-1}, x_i]$. If instead of a polynomial of degree 0, we interpolate $f(x)$, $x \in [x_{i-1}, x_i]$ with the unique polynomial of degree 1 (a segment of a line), which has 2 points in common with the graphic of f , namely the points $M_{i-1}(x_{i-1}, f(x_{i-1}))$ and $M_i(x_i, f(x_i))$ (see Fig.29), we get

$$\begin{aligned} I &= \int_a^b f(x) dx \approx \int_a^b \tilde{f}(x) dx = \\ &= \sum_{i=1}^n \int_{x_{i-1}}^{x_i} \tilde{f}(x) dx = \sum_{i=1}^n \text{area}[x_{i-1}x_iM_{i-1}M_i]. \end{aligned}$$

Since the figure $[x_{i-1}x_iM_{i-1}M_i]$ is a trapezoid, its area is equal to

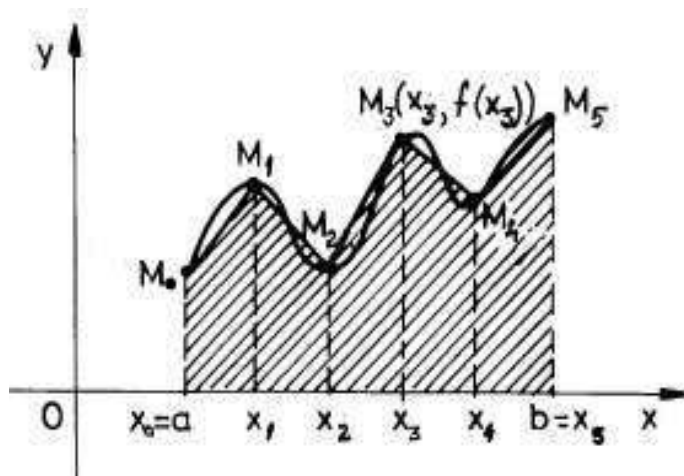

FIGURE 29

$\frac{b-a}{2n} [f(x_{i-1}) + f(x_i)]$. Thus,

$$(9.6) \quad I \approx \sum_{i=1}^n \frac{b-a}{2n} [f(x_{i-1}) + f(x_i)] =$$

$$= \frac{b-a}{2n} \left[f(a) + f(b) + 2 \sum_{i=1}^n f(x_i) \right] \stackrel{\text{def}}{=} T(f, n).$$

This last formula is called the *trapezoids formula*. One can also estimate the error $err = |I - T(f, n)|$ in this case:

$$(9.7) \quad err \leq \frac{M_2}{12n^2} (b-a)^3,$$

where $M_2 = \sup_{x \in [a, b]} |f''(x)|$. For a proof of this last inequality see for instance [GG], pag.139.

Even our feeling says that trapezoids formula gives a better approximation than the rectangles formula, the mathematical estimation of errors (9.5) and (9.7) say contrary, namely, the estimation of error in the case of the rectangles formula is two times smaller than the estimation in the case of the trapezoids formula. In practice, sometimes the error in the case of the trapezoids approximation formula can be less than that one in which we use rectangle formula (for the same equidistant division). Sometimes it is greater! (by drawing, find out some examples!). Since both $R(f, n)$ and $T(f, n)$ are convergent to I , when $n \rightarrow \infty$, for n large enough one can use either rectangles or trapezoids formula.

In order to obtain "better" approximation formulas we need to "interpolate" our integrand function $f(x)$ by a polynomial $P(x)$ of a fixed degree n . This means to fix $n+1$ distinct points $x_0 < x_1 < \dots < x_n$ in $[a, b]$ and to find a polynomial $P(x)$ of degree n such that $P(x_i) = f(x_i)$ for any $i = 0, 1, \dots, n$. We shall see that this last polynomial is unique and it is called the *interpolation polynomial* of f at the *nodes* $\{x_0, x_1, \dots, x_n\}$. In practice, we usually do not know the analytical expression of the function $f(x)$. In fact we measure some values $\{y_0, y_1, \dots, y_n\}$ of it at a given finite number of points $x_0 < x_1 < \dots < x_n$. Thus, $f(x_i) = y_i$ for $i = 0, 1, \dots, n$. Having such an interpolation polynomial we can force the approximation $f(x) \approx P(x)$, $x \in [a, b]$. One can prove that if the number of nodes is greater and greater and if they are "uniformly" distributed (for instance if we use equidistant divisions of $[a, b]$), then the error $\|f - P\| = \sup_{x \in [a, b]} \{|f(x) - P(x)|\}$ becomes smaller and smaller (see [GG] for instance). Let us use this last approximation in order to find an approximation of the integral

$$\int_a^b f(x) dx \approx \int_a^b P(x) dx.$$

This last integral can be easily computed even the degree of P is very large (we can derive an elementary formula which is a function of the coefficients of P and of a and b). Thus, the approximate computation of $\int_a^b f(x)dx$ reduces to an easy task.

Let us reformulate our general problem. Given $n + 1$ nodes (points, numbers, etc.) $x_0 < x_1 < \dots < x_n$ and a fixed arbitrary set of $n + 1$ real numbers $\{y_0, y_1, \dots, y_n\}$, let us find a polynomial $L_n(x)$ (here L is from Lagrange) of degree n such that

$$L_n(x_i) = y_i, \quad i = 0, 1, \dots, n,$$

i.e. the polynomial function $L_n(x)$ is passing through the xOy -plane points $M_i(x_i, y_i)$, $i = 0, 1, \dots, n$ (see Fig.30).

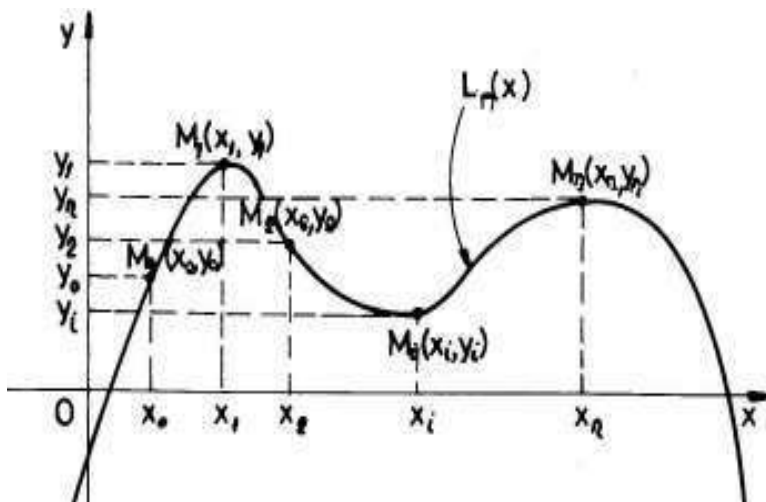

FIGURE 30

Such a polynomial $L_n(x)$ is called a *Lagrange polynomial* corresponding to the nodes $x_0 < x_1 < \dots < x_n$ and to $\{y_0, y_1, \dots, y_n\}$.

THEOREM 27. *Given $x_0 < x_1 < \dots < x_n$ and $\{y_0, y_1, \dots, y_n\}$, there is a unique Lagrange polynomial $L_n(x)$ of degree n which is passing through the points $M_i(x_i, y_i)$, $i = 0, 1, \dots, n$.*

PROOF. Any polynomial $L_n(x)$ of degree n can be represented as

$$L_n(x) = a_0 + a_1x + \dots + a_nx^n,$$

where a_0, a_1, \dots, a_n are unknown coefficients. To determine $L_n(x)$ means to find these coefficients a_0, a_1, \dots, a_n . Conditions $L_n(x_i) = y_i$, $i =$

is a basis in \mathcal{P}_n , the real vector space of all polynomials of degree less or equal to n .

b) The unique Lagrange polynomial $L_n(x)$ which is passing through the set of points $M_i(x_i, y_i)$ (see theorem 27) can be represented as a linear combination of the polynomials $\omega_0(x), \omega_1(x), \dots, \omega_n(x)$:

$$(9.10) \quad L_n(x) = \frac{y_0}{\omega_0(x_0)}\omega_0(x) + \frac{y_1}{\omega_1(x_1)}\omega_1(x) + \dots + \frac{y_n}{\omega_n(x_n)}\omega_n(x).$$

PROOF. a) Since the dimension of \mathcal{P}_n is $n + 1$ ($\{1, x, x^2, \dots, x^n\}$ is a basis of it!), we cannot have more than $n + 1$ linear independent elements in \mathcal{P}_n (see any course in Linear Algebra, for instance see [Po1] or [Po2]). Thus, it is enough to prove that the set of polynomials $\{\omega_0(x), \omega_1(x), \dots, \omega_n(x)\}$ is linear independent. Indeed, let us take a linear combination of them:

$$(9.11) \quad \lambda_0\omega_0(x) + \lambda_1\omega_1(x) + \dots + \lambda_n\omega_n(x) = 0,$$

for any $x \in \mathbb{R}$. Let us put $x = x_0$ in (9.11). Since $\omega_0(x_0) \neq 0$ (x_0, x_1, \dots, x_n are distinct), $\omega_1(x_0) = 0, \dots, \omega_n(x_0) = 0$, we get that $\lambda_0 = 0$. If we put now $x = x_1$ in (9.11), we find $\lambda_1 = 0$, etc. Finally we find that all λ 's are zero, i.e. the set $\{\omega_0(x), \omega_1(x), \dots, \omega_n(x)\}$ is linear independent in \mathcal{P}_n . Having $n + 1$ elements and dimension being $n + 1$, any other polynomial Q cannot be outside the linear subspace generated by $\{\omega_0(x), \omega_1(x), \dots, \omega_n(x)\}$. If we could find such a polynomial, we could enlarge the number of linear independent elements to $n + 2$ which is not possible because the dimension is exactly $n + 1$ (see a course in Linear Algebra, for instance [Po1] or [Po2]). So $\{\omega_0(x), \omega_1(x), \dots, \omega_n(x)\}$ is also a generating system for \mathcal{P}_n , i.e. this set of polynomials is a basis of \mathcal{P}_n .

b) Since $\{\omega_0(x), \omega_1(x), \dots, \omega_n(x)\}$ is a basis, one can write $L_n(x)$ as

$$(9.12) \quad L_n(x) = \mu_0\omega_0(x) + \mu_1\omega_1(x) + \dots + \mu_n\omega_n(x).$$

To compute $\mu_0, \mu_1, \dots, \mu_n$, we successively make $x = x_0, x_1, \dots, x_n$ in (9.12). For instance, if $x = x_0$, we get

$$y_0 = L_n(x_0) = \mu_0\omega_0(x_0),$$

because $\omega_1(x), \dots, \omega_n(x)$ are zero at x_0 . Thus, $\mu_0 = \frac{y_0}{\omega_0(x_0)}$. In the same way we get that $\mu_1 = \frac{y_1}{\omega_1(x_1)}, \dots, \mu_n = \frac{y_n}{\omega_n(x_n)}$, i.e. we just proved formula (9.10). \square

EXAMPLE 44. (interpolation with parabolas) Let us interpolate three points $M_1(x_1, y_1), M_2(x_2, y_2), M_3(x_3, y_3)$ with a parabola, i.e. with a

Lagrange polynomial of degree 2. Let us use formula (9.10) and find

$$(9.13) \quad L_2(x) = \frac{y_1}{\omega_1(x_1)}\omega_1(x) + \frac{y_2}{\omega_2(x_2)}\omega_2(x) + \frac{y_3}{\omega_3(x_3)}\omega_3(x),$$

where $\omega_1(x) = (x - x_2)(x - x_3)$, $\omega_2(x) = (x - x_1)(x - x_3)$ and $\omega_3(x) = (x - x_1)(x - x_2)$.

EXERCISE 5. Write $L_2(x)$ for $x_1 = 0.1$, $x_2 = 0.5$, $x_3 = 0.9$ and $y_1 = 1$, $y_2 = 1.5$, $y_3 = 0.5$. Draw the graphic of the resulting parabola!

Assume now that in Example 44 x_2 is the midpoint of the segment $[x_1, x_3]$. Thus, $x_2 = \frac{x_1+x_3}{2}$. Let us denote by h the differences

$$(9.14) \quad x_2 - x_1 = x_3 - x_2 = \frac{x_3 - x_1}{2} = h.$$

Let us evaluate $I = I[x_1, x_3; y_1, y_2, y_3] = \int_{x_1}^{x_3} L_2(x)dx$. Let us use now formula (9.13) to compute this last integral. Since

$$(9.15) \quad \int_{x_1}^{x_3} L_2(x)dx = y_1 \int_{x_1}^{x_3} \frac{\omega_1(x)}{\omega_1(x_1)}dx + y_2 \int_{x_1}^{x_3} \frac{\omega_2(x)}{\omega_2(x_2)}dx + y_3 \int_{x_1}^{x_3} \frac{\omega_3(x)}{\omega_3(x_1)}dx.$$

it is enough to compute the three integrals which appear on the right side of the formula (9.15). For this, let us change the variable x with a new variable s :

$$x = x_1 + sh.$$

Thus,

$$\begin{aligned} \int_{x_1}^{x_3} \frac{\omega_1(x)}{\omega_1(x_1)}dx &= \frac{h}{2} \int_0^2 (s-1)(s-2)ds = \frac{h}{3}, \\ \int_{x_1}^{x_3} \frac{\omega_2(x)}{\omega_2(x_2)}dx &= -h \int_0^2 s(s-2)ds = \frac{4h}{3}, \\ \int_{x_1}^{x_3} \frac{\omega_3(x)}{\omega_3(x_1)}dx &= \frac{h}{2} \int_0^2 s(s-1)ds = \frac{h}{3} \end{aligned}$$

and formula (9.15) becomes

$$(9.16) \quad \int_{x_1}^{x_3} L_2(x)dx = y_1 \frac{h}{3} + y_2 \frac{4h}{3} + y_3 \frac{h}{3}.$$

Let us consider now a continuous function $f : [a, b] \rightarrow \mathbb{R}$ and an equidistant division $a = x_0 < x_1 < x_2 < \dots < x_{2n} = b$ of the interval $[a, b]$ with $2n$ nodes, where n is a nonzero natural number. Let $h = x_i - x_{i-1} = \frac{b-a}{2n}$. We take the following set of triple points: $\{x_0, x_1, x_2\}$, $\{x_2, x_3, x_4\}$, ..., $\{x_{2n-2}, x_{2n-1}, x_{2n}\}$. For each $\{x_{2i-2}, x_{2i-1}, x_{2i}\}$ we approximate the restriction of f to the interval $[x_{2i-2}, x_{2i}]$ by the Lagrange polynomial $L_2^{(i)}(x)$ which corresponds to the node points $x_{2i-2}, x_{2i-1}, x_{2i}$ and the

value $y_{2i-2} = f(x_{2i-2})$, $y_{2i-1} = f(x_{2i-1})$ and $y_{2i} = f(x_{2i})$ for $i = 1, 2, \dots, n$. If one approximates $\int_a^b f(x)dx$ with

$$S(f, n) = \sum_{i=1}^n \int_{x_{2i-2}}^{x_{2i}} L_2^{(i)}(x) dx$$

and if one uses formula (9.16) to compute each term of this last sum, one gets

$$(9.17) \quad \int_a^b f(x) dx \approx \frac{b-a}{6n} [f(x_0) + f(x_{2n}) + 4(f(x_1) + f(x_3) + \dots + f(x_{2n-1})) + 2(f(x_2) + f(x_4) + \dots + f(x_{2n-2}))].$$

This approximation formula is called *Simpson formula* and if f is of class C^4 then the error can be estimated by

$$err = \left| \int_a^b f(x) dx - S(f, n) \right| \leq \frac{(b-a)^5}{2880} M_4,$$

where $M_4 = \sup_{x \in [a,b]} |f^{(IV)}(x)|$ (see [GG]). For $n = 2$ look at the Fig. 31 to see how we approximate the graphic of f with two arcs of parabolas.

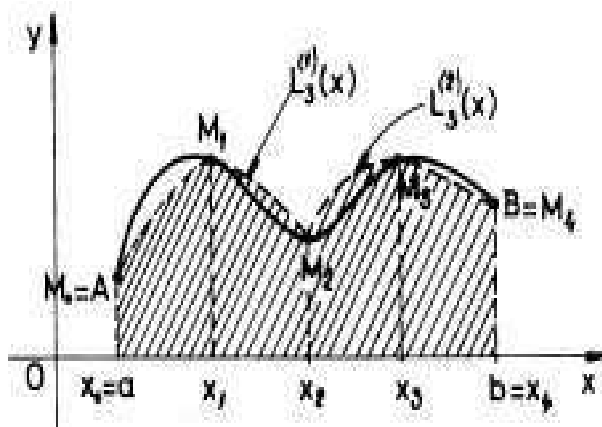

FIGURE 31

If we take an equidistant division $a = x_0 < x_1 < x_2 < \dots < x_n = b$ and if we interpolate the arc $M_{i-1}M_i$, where $M_i(x_i, f(x_i))$, with the Lagrange polynomial of degree 1, i.e. with the segment $[M_{i-1}M_i]$, we get the above discussed trapezoids formula (see (9.6)).

EXERCISE 6. Take $n = 4$ and $f(x) = x^2$ defined on $[0, 1]$. Then $\int_0^1 x^2 dx = \frac{1}{3}$. Use the three approximate formulas $R(f, n)$, $T(f, n)$ and

$S(f, n)$ discussed above to approximate the integral $\int_0^1 x^2 dx$. Compare the results with the exact computation, i.e. with $1/3$.

10. Problems and exercises

1. Compute the following definite integrals:
 a) $\int_1^e \frac{\ln^2 x}{x} dx$; b) $\int_0^{\ln 2} \sqrt{e^x - 1} dx$; c) $\int_1^e \frac{\ln x}{x^2} dx$;
 d) $\int_0^\pi \frac{1}{1 + \cos^2 x} dx$; e) $\int_0^{2\pi} \frac{1}{1 + \cos^2 x} dx$;
2. Prove that if $f : [-a, a] \rightarrow \mathbb{R}$, $a > 0$, f is continuous and even, then $\int_{-a}^a f(x) dx = 2 \int_0^a f(x) dx$.
3. Prove that if $f : [-a, a] \rightarrow \mathbb{R}$, $a > 0$, f is continuous and odd, then $\int_{-a}^a f(x) dx = 0$.
4. Prove that if $f : \mathbb{R} \rightarrow \mathbb{R}$ is continuous and periodic of period $T > 0$ (this means that $f(x+T) = f(x)$ for any x in \mathbb{R} , then $\int_\alpha^{\alpha+T} f(x) dx = \int_0^T f(x) dx$ for any $\alpha \in \mathbb{R}$. In particular, prove that $\int_{-\frac{T}{2}}^{\frac{T}{2}} f(x) dx = \int_0^T f(x) dx$.
5. Compute the area bounded by the curves (help yourself by drawing everything!):
 a) $y = -x^2$, $y = x^2$ and $x = 2$;
 b) $x = y^2$ and $x^2 + y^2 = 2$, $x > 0$;
 c) $\frac{(x-5)^2}{16} + \frac{(y-5)^2}{4} = 0$;
 d) $xy = 1$, $y = 2x$ and $y = \frac{1}{2}x$;
 e) $y = x^2 - 4x + 6$ and $y = -3x^2 + 6$;
 f) $y = \frac{2}{5}x$ and $x = 2 - y - y^2$.
6. The curve $y = \sin x$, $x \in [0, \frac{\pi}{2}]$ rotates around Ox -axis and then around Oy -axis. Compute the two volumes of the revolutionary bodies which result.
7. Find the area bounded by the arc of the parabola $y = 4x^2$, Ox -axis and the lines $x = 0$ and $x = a$ ($a > 0$), using only the definition of definite integral with Riemann sums.
8. Find the area bounded by the curvilinear trapezoid generated by the hyperbola $y = 1/x$, $x = a$, $x = b$ ($0 < a < b$) and Ox -axis.
9. Let $f : [0, 1] \rightarrow \mathbb{R}$ be a continuous function defined on the interval $[a, b]$ with values in \mathbb{R} . Prove that

$$\lim_{n \rightarrow \infty} \frac{1}{n} \sum_{k=1}^n f\left(\frac{k}{n}\right) = \int_0^1 f(x) dx.$$

Use this formula to compute the following limits:

$$\text{a) } S = \lim_{n \rightarrow \infty} \left(\frac{1}{n^2} + \frac{2}{n^2} + \dots + \frac{n-1}{n^2} \right);$$

- b) $S = \lim_{n \rightarrow \infty} \frac{1^5 + 2^5 + \dots + n^5}{n^6}$;
 c) $S = \lim_{n \rightarrow \infty} \left(\frac{1}{n+1} + \frac{1}{n+2} + \dots + \frac{1}{n+n} \right)$;
 d) $S = \lim_{n \rightarrow \infty} \left(\frac{n}{n^2+1^2} + \frac{n}{n^2+2^2} + \dots + \frac{n}{n^2+n^2} \right)$;
 e) $S = \lim_{n \rightarrow \infty} \frac{\sqrt{1} + \sqrt{2} + \dots + \sqrt{n}}{n\sqrt{n}}$.

10. Using the fact that $F(x) = \int_a^x f(t)dt$ is a primitive of $f(x)$, compute:

a) $\lim_{x \rightarrow 1} \frac{\int_1^x \ln t dt}{x-1}$; b) $\lim_{x \rightarrow 0} \frac{\int_0^x \frac{\sin t}{t} dt}{x}$; c) $\lim_{x \rightarrow 0} \frac{\int_0^x \sqrt{1+t^4} dt}{x^3}$.

11. Find the graphic of the function $f(x) = \int_0^x \frac{\sin t}{t} dt$, $x \in \mathbb{R}$.

12. Compute the limits $\lim_{A \rightarrow \infty} \int_0^A e^{-ax} \cos bx dx$ and

$$\lim_{A \rightarrow \infty} \int_0^A e^{-ax} \sin bx dx.$$

13. Find the area bounded by the curves $y = 2 - x^2$ and $y^3 = x^2$.

14. Find the area bounded by the Ox -axis and the arc of the cycloid

$$\begin{cases} x = a(t - \sin t), \\ y = a(1 - \cos t) \end{cases}, t \in [0, 2\pi], a > 0.$$

15. Find the area bounded by the curve: $\rho = a(1 + \cos 2\theta)$, $\theta \in [0, \pi]$ (Draw it!).

16. Find the area bounded by the Bernoulli's lemniscate: $\rho^2 = a^2 \cos 2\theta$, $\theta \in [-\frac{\pi}{4}, \frac{\pi}{4}] \cup [\frac{3\pi}{4}, \frac{5\pi}{4}]$.

17. Find the length of the curves: a) $y = \ln x$, $x \in [\sqrt{3}, \sqrt{8}]$; b) $x = \frac{1}{4}y^2 - \frac{1}{2} \ln y$, $y \in [1, e]$.

18. Find the lengths of the following curves:

a) the cycloid: $\begin{cases} x = a(t - \sin t), \\ y = a(1 - \cos t) \end{cases}$, $t \in [0, 2\pi]$, $a > 0$,

b) the cardioid: $\rho = a(1 + \cos \theta)$, $\theta \in [0, 2\pi]$ and

c) the astroide: $x^{\frac{2}{3}} + y^{\frac{2}{3}} = a^{\frac{2}{3}}$, $a > 0$.

19. Find the volume of the revolutionary ellipsoid determined by the rotation of the ellipse $\frac{x^2}{a^2} + \frac{y^2}{b^2} = 1$, a) around Ox -axis; b) around Oy -axis.

20. Use the formula $S = 2\pi \int_?^? y \sqrt{1 + y'^2} dx$ to find the area of the parabolic mirror generated by the rotation of the arc of parabola $x = \frac{1}{16}ay^2$, $y \in [0, 4a]$, around Ox -axis.

21. The curve $y = a \cosh \frac{x}{a}$ (catenary), $a > 0$, $x \in [0, a]$ rotates around the Ox -axis and gives rise to a surface called catenoid. Find the area of this catenoid.

22. Find the revolutionary areas obtained by the rotation around the Ox -axis of the a) cycloid, b) cardioid and c) astroide from the problem 18.

23. The circle $x^2 + (y - b)^2 = a^2$, $b > a$, rotates around Ox -axis. Find the side area and the volume of the resulting solid (torus).

24. The parabola $y = x^2$, $x \in [0, 1]$ rotates itself around the first bisectrix $y = x$. Find the side area and the volume of the resulting solid (Hint: use Riemann's sums to find appropriate formulas or make first of all a rotation of axes of 45°).

25. Compute: a) $\int_1^{\sqrt{3}} \frac{\sqrt{1+x^2}}{x^2} dx$; b) $\int_1^{2e} |\ln x - 1| dx$;

c) $\int_{-1}^1 \max\left[\left(\frac{1}{3}\right)^x, 3^x\right] dx$;

26. Let us denote by I_n the following definite integral $\int_0^{\frac{\pi}{2}} \sin^n x dx$, $n = 1, 2, \dots$. Prove that $I_n = \frac{n-1}{n} I_{n-2}$. Then compute I_5 and I_6 .

27. Find the coordinates of the mass center of the plane domain bounded by the arc of parabola $y^2 = x$, $y \geq 0$, the Ox -axis and the line $x = 2$.

28. Find the matrix of the momentum of inertia for the arc of the helix:

$$\mathcal{H} := \begin{cases} x = a \cos t \\ y = a \sin t \\ z = bt \end{cases}, \quad a, b > 0, t \in [0, 2\pi].$$

(Hint: $I = \begin{pmatrix} I_{xx} & I_{xy} & I_{xz} \\ I_{xy} & I_{yy} & I_{yz} \\ I_{xz} & I_{yz} & I_{zz} \end{pmatrix}$, where $I_{xx} = \int_0^{2\pi} (y^2 + z^2) ds$, $I_{xy} = \int_0^{2\pi} yz ds$, etc., i.e. the square of the distance of a point $M(x, y, z)$ of \mathcal{H} to the Ox -axis, to the Oxy -plane, etc. Here $ds = \sqrt{x'^2 + y'^2 + z'^2} dt$ is the element of length on the curve \mathcal{H}).

29. Use the formula $ds = \sqrt{x'^2 + y'^2} dt$ to deduce an analogous formula, $ds = \sqrt{\rho^2 + \rho'^2} d\theta$, for a curve given in polar coordinates: $\rho = \rho(\theta)$. Use this last formula to compute the length of the cardioid: $\rho = a(1 + \cos \theta)$, $\theta \in [0, 2\pi]$, where $a > 0$.

30. The parabola $y = \frac{x^2}{4}$, $x \in [0, 3]$, rotates around Oy -axis. Find the volume of the resultant solid.

31. Find the coordinates of the mass center of the figures bounded by the curves:

a) $\frac{x^2}{a^2} + \frac{y^2}{b^2} = 1$, $x, y \geq 0$, $x = 0$, $y = 0$; b) $y = x^2$, $y = \sqrt{x}$, $x \geq 0$.

32. Use the formulas (see also the chapter with line integrals of the first type):

$$\begin{aligned} L &= \int_0^{2\pi} \sqrt{x'^2 + y'^2} dt, \\ x_G &= \frac{\int_0^{2\pi} x \sqrt{x'^2 + y'^2} dt}{L}, \\ y_G &= \frac{\int_0^{2\pi} y \sqrt{x'^2 + y'^2} dt}{L} \end{aligned}$$

in order to compute the coordinates of the mass center of the line:

$$\begin{cases} x = a(t - \sin t) \\ y = a(1 - \cos t) \end{cases}, t \in [0, 2\pi).$$

33. Let $M_1(0, \frac{1}{2})$, $M_2(1, 1)$, $M_3(2, \frac{1}{2})$, $M_4(3, 1)$ and $M_5(4, \frac{1}{2})$ be 5 points in the xOy -plane. Write the Lagrange's polynomial for these points and compute the area bounded by it, the lines $x = 0$, $x = 4$, $y = 0$ and the graphic of this polynomial.

34. Use the trapezoid method with $n = 5$ to approximately compute $\int_0^4 x dx$. Compute this integral by Newton-Leibniz formula and observe the committed error.

CHAPTER 3

Improper (generalized) integrals

1. More on limits of functions of one variable

Usually, whenever we say that a sequence $\{x_n\}$ is convergent to b , b is considered to be a real number. Let us extend the notion of convergence to the "completed" real line $\overline{\mathbb{R}} = \mathbb{R} \cup \{-\infty, \infty\}$. If $b = \infty$, we say $\{x_n\}$ is convergent to b if for any real number M , there exists a rank N_M such that if $n \geq N_M$, then $x_n \geq M$. If $b = -\infty$, we say that $\{x_n\}$ is convergent to b if for any real number M , there exists a rank N_M such that if $n \geq N_M$, then $x_n \leq M$.

Let A be a nonempty subset of \mathbb{R} . We say that $b \in \overline{\mathbb{R}} = \mathbb{R} \cup \{-\infty, \infty\}$ is a *limit point* of A if there exists a nonconstant sequence $\{a_n\}$ of elements of A which is convergent to b . For instance, 0 is a limit point of $A = \{\frac{1}{n}\}$ and ∞ is a limit point of $A = \{n\}$. For an interval I (finite, infinite, closed, open or neither closed nor open) any point of I or of ∂I , the boundary of I in $\overline{\mathbb{R}}$, is a limit point of I (prove it!).

DEFINITION 9. (*limit of a function at a given point*) Let $f : A \rightarrow \mathbb{R}$ be a function defined on a subset A of $\overline{\mathbb{R}}$ with real values and let $b \in \overline{\mathbb{R}}$ be a limit point of A . We say that $L = L(f, b) \in \overline{\mathbb{R}}$ is the limit of f at b if for any sequence $\{x_n\}$, $x_n \in A$, which is convergent to b , the sequence $\{f(x_n)\}$ is convergent to L . If L is finite, i.e. if $L \in \mathbb{R}$, we say that f has the finite limit L at b or that f has the limit L at b . We note this by $L = \lim_{x \rightarrow b} f(x)$.

If in this definition we take only sequences $\{x_n\}$, $x_n \in A$, $x_n < b$, $x_n \rightarrow b$ then, if the limit $L_l(f, b) = \lim_{x_n \rightarrow b, x_n \leq b} f(x_n)$ exist and it is the same for any such sequence, we say that $L_l(f, b)$ is the *left limit* of f at b . If we take sequences $\{x_n\}$, $x_n \in A$, $x_n > b$, $x_n \rightarrow b$ then, if the limit $L_r(f, b) = \lim_{x_n \rightarrow b, x_n \geq b} f(x_n)$ exists and it does not depend on the sequence $\{x_n\}$, we say that $L_r(f, b)$ is the *right limit* of f at b . Sometimes it is not possible to define one of these limits. For instance, if $f : [0, 1] \rightarrow \mathbb{R}$ and $b = 0$, it is not possible to define the left limit of f at 0. In this case we call $L_r(f, 0) = L(f, b)$ the limit of f at 0. $L_l(f, b)$ and $L_r(f, b)$ are called the *side limits* of f at b . Let us use the above definitions to

compute the side limits and the limit of $f : \mathbb{R} \rightarrow \mathbb{R}$, $f(x) = x^2 + 1$ at $x = 2$. If $x_n \rightarrow 2$, $x_n \leq 2$, then $f(x_n) = x_n^2 + 1 \rightarrow 5$. So $L_l(f, 2) = 5$. It is easy to see that $L_r(f, 2) = L(f, 2) = 5$. But, if

$$f(x) = \begin{cases} x^2, & \text{if } x \leq 2 \\ 3, & \text{if } x > 2 \end{cases}, \quad f : \mathbb{R} \rightarrow \mathbb{R},$$

then $L_l(f, 2) = 4$, $L_r(f, 2) = 3$, and $L(f, 2)$ does not exist because, generally speaking, any sequence $\{z_n\}$ which is convergent to 2 and which has an infinite number of terms on the left and on the right of 2, can be written like a union of two subsequences of it, $\{z_{k_n}^{(1)}\}$ and $\{z_{t_n}^{(2)}\}$, such that $z_{k_n}^{(1)} \leq 2$ and $z_{t_n}^{(2)} \geq 2$. This means that $f(z_{k_n}^{(1)}) \rightarrow 4$ and $f(z_{t_n}^{(2)}) \rightarrow 3$, thus the whole sequence $\{f(z_n)\}$ has not a unique limit when $n \rightarrow \infty$. This is why we say that this f has not a limit at 2.

The following theorem makes light on the relation between the side limits and the limit itself.

THEOREM 29. *Let A be a nonempty subset of \mathbb{R} and let b be a limit point of A in \mathbb{R} . Let us assume that both side limits of f at b exist and that they are equal to M . Then f has a limit at b and this limit is equal to M .*

PROOF. Let $\{x_n\}$ be a sequence of elements of A which is convergent to b . If this sequence has either a finite terms on the left of b or a finite terms on the right of b , then the limit of the sequence $\{f(x_n)\}$ is either $L_l(f, b)$ or $L_r(f, b)$ respectively. Since both these numbers are equal to M , the limit of $\{f(x_n)\}$ is M in this case. Assume now that the sequence $\{x_n\}$ is the disjoint union of two subsequences $\{z_{k_n}^{(1)}\}$ and $\{z_{t_n}^{(2)}\}$ such that the terms of $\{z_{k_n}^{(1)}\}$ are on the left of b and the terms of $\{z_{t_n}^{(2)}\}$ are on the right of b . Here "disjoint" means that these last sequences have no terms in common. Since the left limit at b and the right limit at the same point are equal to M , $\{f(z_{k_n}^{(1)})\}$ and $\{f(z_{t_n}^{(2)})\}$ are both convergent to M . Let us prove that the whole sequence $\{f(x_n)\}$ is convergent to M . For this let us take an ε -neighborhood $(M - \varepsilon, M + \varepsilon)$ of M . There are two natural numbers N_1 and N_2 such that if $k_n \geq N_1$ and $t_n \geq N_2$ one has that $f(z_{k_n}^{(1)}) \in (M - \varepsilon, M]$ and $f(z_{t_n}^{(2)}) \in [M, M + \varepsilon)$. Let $N = \max\{N_1, N_2\}$, the greatest element of the set $\{N_1, N_2\}$. Now, if $m \geq N$, then x_m is either a $z_{k_n}^{(1)}$ with $k_n \geq N_1$ or a $z_{t_n}^{(2)}$ with $t_n \geq N_2$. Thus $f(x_m) \in (M - \varepsilon, M + \varepsilon)$ in both cases. Hence, $f(x_m) \rightarrow M$ whenever $m \rightarrow \infty$ and the proof is complete. \square

REMARK 16. *Since on the real line \mathbb{R} we have two directions around a given point b , on the left and on the right, we might be inclined to generalize theorem 29 to the case of a function of many variables, say of two variables, in the following sense. Let A be a nonempty domain (open and connected, see [Po] for instance) of the xOy -plane and let $\mathbf{b} = (b_1, b_2)$ be a limit point of A . Let $f : A \rightarrow \mathbb{R}$ be a function of two variables defined on A with scalar real values. The temptation is to say that if the limit along any straight line which is passing through \mathbf{b} exists and it does not depend on the direction of these lines (this means that there exist a real number L such that if $\{M_n = (x_n, y_n)\}$ is a sequence of points on a line $y - b_2 = m(x - b_1)$ for all slopes m , i.e. $y_n - b_2 = m(x_n - b_1)$ for any n , then $f(x_n, y_n)$ has a limit at \mathbf{b}). But this statement is wrong as follows from the example bellow. Let*

$$f(x, y) = \begin{cases} \frac{y}{\sqrt[3]{x+y}}, & \text{if } y \neq -\sqrt[3]{x} \\ 0, & \text{if } y = -\sqrt[3]{x} \end{cases},$$

$f : \mathbb{R} \rightarrow \mathbb{R}$. Take $\mathbf{b} = (0, 0)$ and an arbitrary line $y = mx$ which passes through $(0, 0)$. If (x_n, y_n) is such that $y_n = mx_n$, then

$$f(x_n, y_n) = \frac{mx_n^{\frac{2}{3}}}{1 + mx_n^{\frac{2}{3}}} \rightarrow 0,$$

when $(x_n, y_n) \rightarrow (0, 0)$. But, if $(x_n, y_n) \rightarrow (0, 0)$, $x_n \neq 0$ and $y_n = \sqrt[3]{x_n}$, then

$$f(x_n, y_n) = \frac{1}{2} \nrightarrow 0.$$

Thus 0 cannot be the limit of f at $(0, 0)$. Hence, even f has the limit 0 on any lines which is passing through $(0, 0)$, it has limit $1/2$ on the cubic curve $y^3 = x$. It can be proved that a function f defined on a plane domain A has limit L at a point \mathbf{b} of A if and only if it has the same limit L along any smooth curve γ which is passing through \mathbf{b} and is contained in A . This comes from the fact that any sequence of points $M_n(x_n, y_n)$ which converges to \mathbf{b} can be interpolated by a smooth curve γ which contains the point \mathbf{b} too. This last statement reduces to the following fact. For any $n = 2, 3, \dots$, three distinct points $P_{n-1}(x_{n-1}, y_{n-1})$, $P_n(x_n, y_n)$, $P_{n+1}(x_{n+1}, y_{n+1})$ and two straight lines d_{n-1} , d_{n+1} which is passing through P_{n-1} and P_{n+1} respectively, there is a parametric curve of class C^1 of the form

$$\Gamma_n := \begin{cases} x(t) = x_{n-1} + A_{n-1}(t - n + 1) + A_n(t - n + 1)^2 + \\ \quad + A_{n+1}(t - n + 1)^3 + C_{n+1}(t - n + 1)^4, \\ y(t) = y_{n-1} + B_{n-1}(t - n + 1) + B_n(t - n + 1)^2 + \\ \quad + B_{n+1}(t - n + 1)^3 + D_{n+1}(t - n + 1)^4 \end{cases},$$

$t \in [n-1, n+1]$ such that it passes through our three points and is tangent to d_{n-1} , d_{n+1} at the points P_{n-1} and P_{n+1} respectively. For $t = n-1$, $x(n-1) = x_{n-1}$ and $y(n-1) = y_{n-1}$. Since $x'(n-1) = A_{n-1}$ and $y'(n-1) = B_{n-1}$, one can find A_{n-1} and B_{n-1} respectively as being the direction of d_{n-1} . Let (l_{n+1}, m_{n+1}) the direction of the line d_{n+1} . Then the coefficients A_n , A_{n+1} , C_{n+1} can be determined by solving the following linear system (in these unknowns A_n , A_{n+1} , and C_{n+1})

$$\begin{cases} 4A_n + 12A_{n+1} + 32C_{n+1} = l_2 - A_{n-1} \\ A_n + A_{n+1} + C_{n+1} = x_n - x_{n-1} - A_{n-1} \\ 4A_n + 8A_{n+1} + 16C_{n+1} = x_{n+1} - x_{n-1} - 2A_{n-1} \end{cases}.$$

The determinant of this linear system is equal to -16 , so the system has a unique solution. This last system came from the conditions that Γ_n be tangent to d_{n+1} at P_{n+1} , $x(n) = x_n$ and $y(n) = y_n$. An analogous system for $y(x)$ will determine the coefficients B_n , B_{n+1} and D_{n+1} . Finally, in order to obtain an interpolating curve Γ of class C^1 for a sequence $\{P_n(x_n, y_n)\}$ which converges to \mathbf{b} , such that Γ passes through \mathbf{b} , we take a sequence of straight lines $\{d_n\}$ with its sequence of slopes $\{m_n\}$ convergent to a real number, say r and Γ to be the joint union of all Γ_n , $n = 2, 4, 6, \dots$, constructed above and the point \mathbf{b} itself with the coordinates $x(\infty)$ and $y(\infty)$. When t runs from 1 up to ∞ , $t \in \overline{\mathbb{R}}$, the corresponding point $M(x(t), y(t))$ goes from $P_1(x_1, y_1)$ up to $P(b_1, b_2)$. Moreover, $M(x(t), y(t))$ is passing through $P_2, P_3, \dots, P_n, \dots$ successively.

Practically, how do we prove that a function $f : A \rightarrow \mathbb{R}$ has a limit L at a limit point $b \in \overline{\mathbb{R}}$ of A and how do we compute it? We simply take an arbitrary sequence $\{x_n\}$, $x_n \in A$ for all n , which converges to b and then ask ourselves if the sequence $\{f(x_n)\}$ is convergent to L . If we do not know the value of L in advance, we compute the limit of $\{f(x_n)\}$ if it exists and, if this limit exists and if it does not depend of the sequence $\{x_n\}$ which converges to b , we must conclude that f has this last limit just computed at the point b .

For instance, let us study if the function $f(x) = \ln(x^2 + 1)$ has a limit at $x = 0$. For this let $x_n \rightarrow 0$ be a sequence which converges to 0. Then, taking count of the usual elementary operations with sequences, we get that $x_n^2 + 1 \rightarrow 1$. Since the function $\ln : (0, \infty) \rightarrow \mathbb{R}$ is continuous as being an elementary function (see [Po]), we get that the sequence $\ln(x_n^2 + 1) \rightarrow \ln 1 = 0$. This last number does not depend on the convergent to zero sequence $\{x_n\}$, so the function $f(x) = \ln(x^2 + 1)$ has the limit $L = 0$ at $x = 0$. In particular, the both side limits of f at zero are equal to zero.

The following two criteria are very useful in this chapter.

THEOREM 30. (ε - δ criterion) *Let A be an interval in \mathbb{R} and let b be a limit point of it in $\overline{\mathbb{R}}$. Let $f : A \rightarrow \mathbb{R}$ be a function defined on A with real values. a) Assume that b is finite, i.e. it is in \mathbb{R} . Then f has a limit $L \in \mathbb{R}$ at b if and only if for any $\varepsilon > 0$ (usually small) there exists a real number δ which depends on ε such that whenever $x \in A \cap (b - \delta, b + \delta)$, then $f(x) \in (L - \varepsilon, L + \varepsilon)$, i.e. $|f(x) - L| < \varepsilon$. This means that if we go with x very close to b , then $f(x)$ becomes very close to L . b) Assume now that $b = \infty$. Then f has a limit L at b if and only if for any $\varepsilon > 0$ (usually small) there exists a sufficiently large number $\delta > 0$ which depends on ε such that whenever $x \in (\delta, b = \infty)$ (a neighborhood of ∞), then $f(x) \in (L - \varepsilon, L + \varepsilon)$, i.e. $|f(x) - L| < \varepsilon$. This means that if we push x very close to ∞ , then $f(x)$ becomes very close to L . If $b = -\infty$, then $\delta < 0$ and $-\delta$ is large enough, i.e. in this last case δ is very close to $-\infty$. Moreover, the expression " $x \in (\delta, b = \infty)$ (a neighborhood of ∞)" must be substituted with " $x \in (-\infty, \delta)$ (a neighborhood of $-\infty$)".*

PROOF. a) Suppose that f has a limit $L \in \mathbb{R}$ at $b \in \mathbb{R}$, i.e. for all sequences $x_n \rightarrow b$ one has that $f(x_n) \rightarrow L$. If for a fixed $\varepsilon > 0$ such a number δ did not exist, then, for every natural number $n = 1, 2, \dots$, we could find a $z_n \in A \cap (b - 1/n, b + 1/n)$ such that $f(z_n) \notin (L - \varepsilon, L + \varepsilon)$. Thus $z_n \rightarrow b$ and $\{f(z_n)\}$ does not converge to L , i.e. L cannot be a limit for f at b , a contradiction! Hence such a δ with the required properties in the statement of the theorem must exist.

Conversely, assume that for any $\varepsilon > 0$ there exists a δ with the property described in the theorem. Take $x_n \rightarrow b$, $x_n \in A$ and take also a small $\varepsilon > 0$. For the corresponding δ (which depend on ε) one can find a natural number N which depend on this δ such that if $n \geq N$, then $x_n \in A \cap (b - \delta, b + \delta)$. Use now the assumption and conclude that for $n \geq N$, $f(x_n) \in (L - \varepsilon, L + \varepsilon)$, i.e. $f(x_n) \rightarrow L$, so L is the limit of f at the point b .

b) If $b = \infty$, let us assume that L is the limit of f at $b = \infty$, i.e. $x_n \rightarrow \infty$, $x_n \in A$, then $f(x_n) \rightarrow L$. If one could find an $\varepsilon > 0$ for which such a large number δ (depending on ε) with the property described in theorem, b), did not exist, then, for this ε and for any $n = 1, 2, \dots$ we could construct a $y_n \in A \cap (n, \infty)$ such that $f(y_n) \notin (L - \varepsilon, L + \varepsilon)$. Hence, $y_n \rightarrow \infty$ and $f(y_n) \not\rightarrow L$, a contradiction! So such a δ must exist.

Conversely, if for any small $\varepsilon > 0$ there exists a δ with the properties described in theorem, b), take a sequence $t_n \rightarrow b = \infty$, $t_n \in A$. For such δ one can find a natural number M such that if $n \geq M$, one has that $t_n \in A \cap (\delta, \infty)$. Let us use now the hypothesis and conclude that

$f(t_n) \in (L - \varepsilon, L + \varepsilon)$ for any $n \geq M$. Thus $f(t_n) \rightarrow L$ and the proof is completed. \square

Sometimes we cannot even guess the limit L in order to use the above definition of the limit of f at b . For instance, let $A = [0, \infty)$, $b = \infty$ and $f(x) = \int_0^x e^{-t^2} dt$, the famous Laplace error function which is a basic mathematical tool in statistics. In higher mathematics it is proved that the function $g(t) = e^{-t^2}$ has no elementary primitives, so we can never express $f(x)$ as a composition of elementary functions (polynomial, rational, trigonometric, exponential and logarithmic functions). Thus, if $x_n \rightarrow \infty$, how do we prove that the sequence $\left\{ f(x_n) = \int_0^{x_n} e^{-t^2} dt \right\}$ is convergent? How do we compute its limit? The following criterion of Cauchy can decide if a limit of a function f at a given point $b \in \overline{\mathbb{R}}$ exists or not, without guess a number L which could be a good candidate for the limit itself.

THEOREM 31. (*Cauchy criterion*) *Let A be an interval of \mathbb{R} and let $b \in \overline{\mathbb{R}}$ be a limit point of it. Let $f : A \rightarrow \mathbb{R}$ be a function defined on A , with values in \mathbb{R} . a) If b is finite, i.e. if $b \in \mathbb{R}$, then f has a limit at b if and only if for any small real number $\varepsilon > 0$ there is a real number $\delta > 0$ such that if two numbers x' and x'' are in $A \cap (b - \delta, b + \delta)$, then the distance between $f(x')$ and $f(x'')$ is less than ε , i.e. $|f(x') - f(x'')| < \varepsilon$. b) If b is not finite, say $b = \infty$, then f has a limit at b if and only if for any small real number $\varepsilon > 0$ there is a large real number $\delta > 0$ such that if two numbers x' and x'' are greater than δ , then the distance between $f(x')$ and $f(x'')$ is less than ε , i.e. $|f(x') - f(x'')| < \varepsilon$. For $b = -\infty$ we must replace this last δ with a negative, near to $-\infty$, δ , i.e. in this case $\delta < 0$ and $-\delta$ is very large. Moreover, the expression " x' and x'' are greater than δ " must be substituted with " x' and x'' are less than δ ".*

PROOF. a) Assume that L is the limit of f at b . Use now ε - δ criterion (see theorem 30, a)) for $\varepsilon/2$ instead of ε . Thus, there exists a $\delta > 0$ such that if $x \in A \cap (b - \varepsilon/2, b + \varepsilon/2)$, then $|f(x) - L| < \varepsilon/2$. Take now this δ and for $x', x'' \in A \cap (b - \varepsilon/2, b + \varepsilon/2)$ one has that $|f(x') - L| < \varepsilon/2$ and $|f(x'') - L| < \varepsilon/2$. But

$$|f(x') - f(x'')| \leq |f(x') - L| + |f(x'') - L| < \varepsilon/2 + \varepsilon/2 = \varepsilon.$$

Conversely, suppose that for any $\varepsilon > 0$, there is a real number $\delta > 0$, such that if two numbers x' and x'' are in $A \cap (b - \delta, b + \delta)$, then the distance between $f(x')$ and $f(x'')$ is less than ε , i.e. $|f(x') - f(x'')| < \varepsilon$. We must prove that f has a limit L at b . For this, let $x_n \rightarrow b$, $x_n \in A$, and let fix a small $\varepsilon > 0$. For this ε we take that $\delta > 0$, defined by

the above hypothesis. Let N be a natural number such that if $n \geq N$, then $x_n \in A \cap (b - \delta, b + \delta)$. Applying our hypothesis to that fixed ε , we get that for any $n, m \geq N$, one has that $|f(x_n) - f(x_m)| < \varepsilon$, i.e. the sequence $\{f(x_n)\}$ is a Cauchy sequence which has a limit L , depending on the sequence $\{x_n\}$ which converges to b . If we take another sequence $y_n \rightarrow b$ and the same fixed ε with its corresponding δ , since $x_n, y_n \in A \cap (b - \delta, b + \delta)$ for any $n \geq N_*$, common to both sequences, one has that $|f(x_n) - f(y_n)| < \varepsilon$, i.e. the sequences $\{f(x_n)\}$ and $\{f(y_n)\}$ have one and the same limit L . Thus this L is the limit of f at b .

b) Assume now that $b = \infty$ and that f has the limit L at ∞ . Use again ε - δ criterion (see theorem 30, b)) for $\varepsilon/2$ instead of ε and continue the same reasoning as in the finite case a).

Conversely, assume that for any small real number $\varepsilon > 0$ there is a large real number $\delta > 0$ such that if two numbers x' and x'' are greater than δ , then the distance between $f(x')$ and $f(x'')$ is less than ε , i.e. $|f(x') - f(x'')| < \varepsilon$. We must prove that f has limit at $b = \infty$. For this take a sequence $x_n \rightarrow \infty$, $x_n \in A$ and an arbitrary small real number $\varepsilon > 0$. For this ε take the above δ and take a natural number N such that if $n \geq N$, then $x_n > \delta$. Take now $n, m \geq N$. Thus, $x_n, x_m > \delta$ and $|f(x_n) - f(x_m)| < \varepsilon$, i.e. the sequence $\{f(x_n)\}$ is a Cauchy sequence. So it is a convergent to L sequence. Like in the proof of a) one can prove that this L does not depend on the sequence $\{x_n\}$ which converges to b . Hence L is the limit of f at $b = \infty$. \square

EXAMPLE 45. (*Laplace error function*) Let us use Cauchy criterion described above to prove that the famous Laplace error function $f(x) = \int_0^x e^{-t^2} dt$, $x \geq 0$, has a (finite) limit at $b = \infty$. Take for this x' and $x'' \geq 0$ and let us evaluate the distance between $f(x')$ and $f(x'')$:

$$(1.1) \quad |f(x') - f(x'')| = \left| \int_{x'}^{x''} e^{-t^2} dt \right| \leq \left| \int_{x'}^{x''} e^{-t} dt \right| = \left| e^{-x'} - e^{-x''} \right|,$$

where $x', x'' > 1$. Take now a small $\varepsilon > 0$ and choose $\delta > 0$ large enough such that if $x \geq \delta$ one has that $e^{-x} < \varepsilon/2$. This is possible because $e^{-x} \rightarrow 0$, when $x \rightarrow \infty$. Coming back to formula (1.1) we finally get that

$$|f(x') - f(x'')| < \varepsilon/2 + \varepsilon/2 = \varepsilon.$$

Thus Cauchy criterion works and so f has a limit at ∞ . This limit is denoted by $\int_0^\infty e^{-t^2} dt$ and its computation will be given in the next two chapters. It is a first example of an improper (generalized) integral. It is called in the literature the "Poisson integral" and its value is $\frac{\sqrt{\pi}}{2}$. Why an "improper integral"? Because the interval on which we perform

the integral computation of the function e^{-t^2} is not finite (bounded). In the next section we shall systematically study such type of integrals.

2. Improper integrals of the first type

Up to now we have studied integrals on closed and bounded intervals or on some finite unions of these, namely on subsets of the form $A = \cup_{i=1}^n [a_i, b_i]$, where $a_i < b_i \leq a_{i+1} < b_{i+1}$ for any $i = 1, 2, \dots, n-1$. Let us call such type of subsets, *elementary subsets*. We shall now extend the usual notion of Riemann integrals on such type of subsets to unbounded intervals or on a union between an elementary subset and one or two unbounded intervals of the form $[a, \infty)$ or $(-\infty, b]$ under the hypotheses that any two of such subsets have in common at most a point. For instance,

$$B = (-\infty, -5] \cup [-5, 0] \cup [1, 2] \cup [5, \infty)$$

is such a union. Since we can define $\int_{-\infty}^b f(x)dx$ by $\int_{-b}^{\infty} f(-y)dy$ (make the "change of variable" $y = -x$ in your mind!), we can reduce everything to the definition of an integral of the following type $\int_a^{\infty} f(x)dx$, where f is a function defined on $[a, \infty)$. For $\int_{-\infty}^{\infty} f(x)dx$ we simply define it by $\lim_{\delta \rightarrow \infty} \int_{-\delta}^{\delta} f(x)dx$. If this last limit exists, then it is equal to $\int_{-\infty}^0 f(x)dx + \int_0^{\infty} f(x)dx$ (see their definitions bellow). If the limit $\lim_{\delta \rightarrow \infty} \int_{-\delta}^{\delta} f(x)dx$ exists, we call it the *principal value* (pv) of the improper integral $\int_{-\infty}^{\infty} f(x)dx$. For instance, take the integral $\int_{-\infty}^{\infty} \frac{1}{x^2+1} dx$:

$$pv \int_{-\infty}^{\infty} \frac{1}{x^2+1} dx = \lim_{\delta \rightarrow \infty} \int_{-\delta}^{\delta} \frac{1}{x^2+1} dx = \tan^{-1} \infty - \tan^{-1}(-\infty) = \pi.$$

DEFINITION 10. Let $f : [a, \infty) \rightarrow \mathbb{R}$ be a function defined on the unbounded interval (infinite interval) $[a, \infty)$ with real values such that it is integrable on any subinterval of the form $[a, x] \subset [a, \infty)$. If the new function $F(x) = \int_a^x f(t)dt$, $F : [a, \infty) \rightarrow \mathbb{R}$ has a limit $L \in \mathbb{R}$ at $b = \infty$, we say that the symbol $\int_a^{\infty} f(x)dx$ is convergent (or exists) and its value is that L , i.e.

$$\int_a^{\infty} f(x)dx = \lim_{x \rightarrow \infty} \int_a^x f(t)dt,$$

if this last limit exists. If the limit does not exist as a real number, we say that the integral $\int_a^{\infty} f(x)dx$ is divergent or that it does not exist. Such integrals like $\int_a^{\infty} f(x)dx$, $\int_{-\infty}^b f(x)dx$, or $\int_{-\infty}^{\infty} f(x)dx$ are called improper (generalized) integrals of the first type.

For instance, $\int_0^\infty \frac{1}{1+x^2} dx$ is convergent because

$$\lim_{x \rightarrow \infty} \int_0^x \frac{1}{1+t^2} dt = \lim_{x \rightarrow \infty} [\arctan x - \arctan 0] = \frac{\pi}{2}.$$

Thus, $\int_0^\infty \frac{1}{1+x^2} dx = \frac{\pi}{2}$.

EXAMPLE 46. (*Gabriel's trumpet*) Let us take $a > 0$ and $f(x) = \frac{1}{x}$ defined on the infinite interval $[a, \infty)$. Let us take $A > a$ and let us rotate the arc of the graphic of f restricted to $[a, A]$ around Ox -axis. The side surface of the solid obtained in this way is like a trumpet. Let us make A go to ∞ . The "infinite" trumpet obtained in this way is called a Gabriel's trumpet. The infinite area bounded by the graphic of $f(x)$, $x \in [a, \infty)$, the lines $x = a$ and the Ox -axis (see Fig.1)

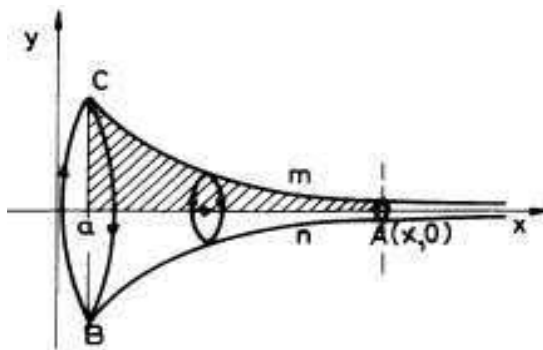

FIGURE 1

is

$$\int_a^\infty \frac{1}{x} dx = \lim_{x \rightarrow \infty} \int_a^x \frac{1}{t} dt = \lim_{x \rightarrow \infty} [\ln x - \ln a] = \infty,$$

so this last improper integral is divergent. Let us compute the volume of the revolutionary solid bounded by the Gabriel's trumpet:

$$\pi \int_a^\infty \frac{1}{x^2} dx = \pi \lim_{x \rightarrow \infty} \int_a^x \frac{1}{t^2} dt = \pi \lim_{x \rightarrow \infty} \left[-\frac{1}{x} + \frac{1}{a} \right] = \frac{\pi}{a}.$$

Thus the volume of this infinite solid is finite, namely $\frac{\pi}{a}$. Hence the last improper integral of the first type is convergent. If $a > 0$ goes to zero, the volume goes to ∞ . Very strange! The area of a longitudinal central section of the Gabriel's trumpet is infinite and its volume is finite!

THEOREM 32. (*zero criterion*) Let us consider the conditions and notation from definition 10. If the integral $\int_a^\infty f(x) dx$ is convergent, then there exists at least one sequence $\{q_n\}$, $q_n \rightarrow \infty$, such that $f(q_n) \rightarrow$

0. In particular, if the integral $\int_a^\infty f(x)dx$ is convergent, and if $\lim_{x \rightarrow \infty} f(x)$ exists, then it must be zero. Thus, if the integral $\int_a^\infty f(x)dx$ is convergent, if f is continuous and if $\lim_{x \rightarrow \infty} f(x)$ exists, then f must be bounded. Hence, if $\lim_{x \rightarrow \infty} f(x)$ exists and it is not equal to zero, then the improper integral $\int_a^\infty f(x)dx$ is divergent.

PROOF. Let n_0 be the least natural number greater than a . Then

$$\int_a^\infty f(x)dx = \int_a^{n_0} f(x)dx + \sum_{n=n_0}^{\infty} \int_n^{n+1} f(x)dx.$$

But

$$\int_n^{n+1} f(x)dx = f(q_n) \int_n^{n+1} dx = f(q_n),$$

where $q_n \in [n, n+1]$ (mean theorem). Since the series $\sum_{n=n_0}^{\infty} \int_n^{n+1} f(x)dx$ is convergent, its general term $f(q_n)$ converges to zero, when $n \rightarrow \infty$. The other statements are simple consequences of the definition of a limit of a function at ∞ ($\lim_{x \rightarrow \infty} f(x) = \lim_{n \rightarrow \infty} f(q_n) = 0$ for any sequence $q_n \rightarrow \infty$) and of the basic properties of sequences on a compact interval (see [P \bullet], Weierstrass theorem). Indeed, if f were not bounded, there exists a sequence $\{x_n\}$, $x_n \in [a, \infty)$ for $n = 1, 2, \dots$, such that $f(x_n) \rightarrow \infty$ (say; you can easily put $-\infty$ instead ∞). If $\{x_n\}$ itself is bounded, there is a subsequence $\{x_{k_n}\}$ of $\{x_n\}$ with $x_{k_n} \rightarrow x_0 \in [a, \infty)$ (Cesàro's Lemma, a particular case of Weierstrass theorem, see [P \bullet]). The continuity of f implies that $f(x_{k_n}) \rightarrow f(x_0)$. Since $\{f(x_{k_n})\}$ is a subsequence of $\{f(x_n)\}$, then $f(x_{k_n}) \rightarrow \infty$. The uniqueness of the limit of a sequence implies that $f(x_0) = \infty$, a pure contradiction! Thus the sequence $\{x_n\}$ is not bounded to ∞ . Let $\{x_{t_n}\}$ be a subsequence of $\{x_n\}$ with $x_{t_n} \rightarrow \infty$. Since $\lim_{x \rightarrow \infty} f(x) = 0$, one has that $f(x_{t_n}) \rightarrow 0$. But $f(x_{t_n}) \rightarrow \infty$, $\{x_{t_n}\}$ being a subsequence of $\{x_n\}$, thus we again obtain a contradiction ($0 = \infty!$). Hence f cannot be unbounded. \square

Here is an example of an unbounded function $f(x)$ on $[a, \infty)$ such that $\int_a^\infty f(x)dx$ is convergent (contrary to a Riemann integral on a finite and closed interval $[a, b]!$). Take N large enough such that $N \geq a$ and define $f : [a, \infty) \rightarrow \mathbb{R}$, $f(N+i) = N+i$ for any $i = 0, 1, 2, \dots$ and $f(x) = 0$ for any $x \notin \{N, N+1, N+2, \dots\}$. Using only the definition of an improper integral of the first type and theorem 19 we see that $\int_a^\infty f(x)dx$ is convergent and it is zero, in spite of that fact that f is unbounded: $f(N+i) = N+i \rightarrow \infty$, when $i \rightarrow \infty$.

The following example is a standard example.

EXAMPLE 47. Let a be a positive real number. For any $\alpha \in \mathbb{R}$ we define $I(\alpha) = \int_a^\infty \frac{1}{x^\alpha} dx$. Then this integral is convergent if and only if $\alpha > 1$. Indeed, if $\alpha = 1$, $I(1) = \ln x \Big|_a^\infty = \infty$. Assume that $\alpha \neq 1$. Then

$$F(x) = \int_a^x \frac{1}{t^\alpha} dt = \frac{t^{-\alpha+1}}{-\alpha+1} \Big|_a^x = \frac{x^{-\alpha+1}}{-\alpha+1} - \frac{a^{-\alpha+1}}{-\alpha+1}.$$

Since $\lim_{x \rightarrow \infty} x^{-\alpha+1}$ is finite and 0 in this case, if and only if $-\alpha+1 < 0$, i.e. $\alpha > 1$.

There is a great number of similarities between the improper integrals of the first type and the numerical series. First of all, for a function $f : [a, \infty) \rightarrow \mathbb{R}_+$, such that for any $x > a$ the "proper" integral $\int_a^x f(t) dt$ exists, let us write formally (for a fixed natural number $N \geq a$):

$$(2.1) \quad \int_a^\infty f(x) dx = \int_a^N f(x) dx + \sum_{n=N}^\infty c_n,$$

where $c_n = \int_n^{n+1} f(x) dx$, $n = N, N+1, \dots$. It is clear that the improper integral is convergent if and only if the last numerical series on the right is convergent (sketch a proof!). If f has positive and also negative values "up to ∞ ", this statement is not always true. Indeed, let $f(x) = \sin 2\pi x$, $x \in [0, \infty)$. Since

$$F(x) = \int_0^x \sin 2\pi t dt = -\frac{\cos 2\pi t}{2\pi} \Big|_0^x = \frac{1}{2\pi} [1 - \cos 2x],$$

and since $\cos x$ has no limit at ∞ , $F(x)$ has no limit at ∞ . Thus the improper integral $\int_0^\infty \sin 2\pi x dx$ is not convergent.

However, $c_n = \int_n^{n+1} \sin 2\pi x dx = 0$ and the series on the right in formula (2.1) is equal to zero!

We recall a nice theorem (theorem 21-the integral test, [Po]) which is stated here in language of improper integrals.

THEOREM 33. (series test) Let $f : [a, \infty) \rightarrow \mathbb{R}_+$, be a function f defined on an interval $[a, \infty)$, $a \geq 0$, with nonnegative values. Assume also that f is a continuous and a decreasing function. Let N be the first natural number greater or equal to a and let $c_n = f(n)$ for any $n = N, N+1, \dots$. Then the improper integral $\int_a^\infty f(x) dx$ is convergent if and only if the numerical series $\sum_{n=N}^\infty c_n$ is convergent.

Since the proof of this result was done in [Po], theorem 21, we omit it here.

For instance, the integral $\int_a^\infty \frac{1}{x^{100+1}} dx$, $a \geq 0$, is convergent because the numerical series $\sum_{n=[a]+1}^\infty \frac{1}{n^{100+1}}$ is convergent (apply the limit comparison test with the Riemann series for $\alpha = 100 > 1$, etc.). To try to compute directly a primitive for $\frac{1}{x^{100+1}}$ is a crazy idea! And, if we know that this integral is convergent but we cannot compute it exactly, where is the practical gain? There is a big one! If we know that this integral is convergent we can approximate it with $\int_a^M \frac{1}{x^{100+1}} dx$, where M is a large natural number. But this last integral can be easily approximately computed by using some specialized software.

If we try to use approximate methods for computing a divergent improper integral is another crazy idea! This means to obtain different numerical values which are randomly distributed to ∞ . Thus these values cannot approximate some unknown number!

This is way we need some tests in order to decide if an improper integral is convergent or not. A basic test is obtained by applying the Cauchy criterion for limits of functions (see theorem 31).

THEOREM 34. (*Cauchy criterion for improper integrals I*)

Let $f : [a, \infty) \rightarrow \mathbb{R}$ be a function which is integrable on any finite interval $[a, x]$ for $x \in [a, \infty)$. Then $\int_a^\infty f(x)dx$ is convergent if and only if for any small $\varepsilon > 0$, there exists δ large enough and depending on ε , such that if $x', x'' \in [\delta, \infty)$, then $\left| \int_{x'}^{x''} f(x)dx \right| < \varepsilon$. This is equivalent to say that $\int_{x'}^{x''} f(x)dx \rightarrow 0$, whenever $x', x'' \rightarrow \infty$.

PROOF. We simply apply theorem 31, b) to the function $F(x) = \int_a^x f(t)dt$, etc. \square

EXAMPLE 48. Let us study the convergence of the integral $I = \int_1^\infty \frac{\arctan x}{x^2} dx$. Practically we want to prove that the limit of the function $G(x', x'') = \left| \int_{x'}^{x''} \frac{\arctan x}{x^2} dx \right|$ is equal to zero, whenever $x', x'' \rightarrow \infty$, independently. Indeed, use the basic mean theorem (see theorem 22) and find

$$\left| \int_{x'}^{x''} \frac{\arctan x}{x^2} dx \right| = |\arctan c| \left| \int_{x'}^{x''} \frac{1}{x^2} dx \right| \leq \frac{\pi}{2} \left| \frac{1}{x'} - \frac{1}{x''} \right| \rightarrow 0,$$

when $x', x'' \rightarrow \infty$.

This last test is very used to derive other more useful in practice tests. In many cases the following test reduces the study of the improper integrals of the first type $\int_a^\infty f(x)dx$ to the case of the nonnegative function $|f(x)|$. If the integral $\int_a^\infty |f(x)| dx$ is convergent, we say that $\int_a^\infty f(x)dx$ is *absolutely convergent*.

THEOREM 35. (*absolute convergence implies convergence*) Suppose that the integral $\int_a^\infty f(x)dx$ is absolutely convergent. Then it is also convergent.

PROOF. Since $\int_a^\infty f(x)dx$ is absolutely convergent, one has that the integral $\int_a^\infty |f(x)| dx$ is convergent, so by using Cauchy criterion we have that

$$\left| \int_{x'}^{x''} |f(x)| dx \right| \rightarrow 0,$$

whenever $x', x'' \rightarrow \infty$. Since

$$\left| \int_{x'}^{x''} f(x)dx \right| \leq \left| \int_{x'}^{x''} |f(x)| dx \right|,$$

one has that $\left| \int_{x'}^{x''} f(x)dx \right| \rightarrow 0$, whenever $x', x'' \rightarrow \infty$, i.e. our integral $\int_a^\infty f(x)dx$ is also convergent. \square

For instance, let us prove that the integral $I = \int_1^\infty \frac{\sin x}{x^2} dx$ is convergent. We shall prove that it is absolutely convergent. Indeed,

$$\left| \int_{x'}^{x''} \frac{|\sin x|}{x^2} dx \right| \leq \left| \int_{x'}^{x''} \frac{1}{x^2} dx \right| = \left| \frac{1}{x'} - \frac{1}{x''} \right| \rightarrow 0,$$

when x' and x'' go to ∞ . Applying again Cauchy criterion, we get that the integral I is absolutely convergent.

We give now some convergence criteria for improper integrals of the first type of nonnegative functions.

THEOREM 36. (*comparison test 1*) Let $f, g : [a, \infty) \rightarrow \mathbb{R}_+$ be two functions defined on the interval $[a, \infty)$ with nonnegative values, integrable on any subinterval $[a, x] \subset [a, \infty)$ and such that $f(x) \leq g(x)$ for any $x \in [a, \infty)$. i) If $\int_a^\infty g(x)dx$ is convergent, then $\int_a^\infty f(x)dx$ is also convergent. ii) If $\int_a^\infty f(x)dx$ is divergent, then $\int_a^\infty g(x)dx$ is also divergent.

PROOF. We apply the Cauchy criterion in both cases.

i) If $\int_a^\infty g(x)dx$ is convergent, then

$$\left| \int_{x'}^{x''} g(x)dx \right| \rightarrow 0,$$

when $x', x'' \rightarrow \infty$. But

$$\left| \int_{x'}^{x''} f(x)dx \right| \leq \left| \int_{x'}^{x''} g(x)dx \right| \rightarrow 0,$$

so $\left| \int_{x'}^{x''} f(x) dx \right| \rightarrow 0$, whenever $x', x'' \rightarrow \infty$. Hence $\int_a^\infty f(x) dx$ is convergent.

ii) If $\int_a^\infty g(x) dx$ were convergent, from i) we would have that $\int_a^\infty f(x) dx$ is convergent, a contradiction. So $\int_a^\infty g(x) dx$ must be divergent. \square

For instance, since

$$\frac{1}{x^8 + 7} < \frac{1}{x^8}$$

and since $\int_1^\infty \frac{1}{x^8} dx$ is convergent ($\alpha = 8 > 1$ in example 47), this last theorem tells us that $\int_1^\infty \frac{1}{x^8 + 7} dx$ is convergent. Since

$$\int_0^\infty \frac{1}{x^8 + 7} dx = \int_0^1 \frac{1}{x^8 + 7} dx + \int_1^\infty \frac{1}{x^8 + 7} dx,$$

and since $\int_0^1 \frac{1}{x^8 + 7} dx$ is a proper integral, one has that $\int_0^\infty \frac{1}{x^8 + 7} dx$ is a convergent integral. This is because

$$\begin{aligned} \lim_{x \rightarrow \infty} \int_0^x \frac{1}{t^8 + 7} dt &= \lim_{x \rightarrow \infty} \int_0^1 \frac{1}{t^8 + 7} dt + \lim_{x \rightarrow \infty} \int_1^x \frac{1}{t^8 + 7} dt = \\ &= \int_0^1 \frac{1}{t^8 + 7} dt + \int_1^\infty \frac{1}{t^8 + 7} dt. \end{aligned}$$

THEOREM 37. (*limit comparison test*) Let $f, g : [a, \infty) \rightarrow \mathbb{R}_+$ be two functions defined on the interval $[a, \infty)$ with nonnegative values, integrable on any subinterval $[a, x] \subset [a, \infty)$. Assume in addition that $g(x) > 0$ for any $x \in [a, \infty)$ and that the following limit "exists": $\lim_{x \rightarrow \infty} \frac{f(x)}{g(x)} = L \in \mathbb{R} \cup \{\infty\}$.

i) If $L \neq 0, \infty$, then the improper integrals $\int_a^\infty f(x) dx$ and $\int_a^\infty g(x) dx$ have the same nature, i.e. they are simultaneously convergent or divergent.

ii) If $L = 0$ and $\int_a^\infty g(x) dx$ is convergent, then $\int_a^\infty f(x) dx$ is also convergent.

iii) If $L = \infty$ and $\int_a^\infty g(x) dx$ is divergent, then $\int_a^\infty f(x) dx$ is also divergent.

PROOF. i) Take an $\varepsilon > 0$ sufficiently small such that $L - \varepsilon > 0$ (since f and g have nonnegative values, L is nonnegative). Since $\lim_{x \rightarrow \infty} \frac{f(x)}{g(x)} = L$, there exists a large enough $\delta > a$ such that if $x \in [\delta, \infty)$, then

$$(2.2) \quad L - \varepsilon < \frac{f(x)}{g(x)} < L + \varepsilon,$$

or

$$(2.3) \quad (L - \varepsilon)g(x) < f(x) < (L + \varepsilon)g(x).$$

If $\int_a^\infty f(x)dx$ is convergent, then $\int_\delta^\infty f(x)dx$ and $\int_\delta^\infty \frac{f(x)}{L-\varepsilon}dx$ are also convergent; since $g(x) < \frac{f(x)}{L-\varepsilon}$, one has that $\int_\delta^\infty g(x)dx$ is also convergent (see theorem 36). Since

$$\int_a^\infty g(x)dx = \int_a^\delta g(x)dx + \int_\delta^\infty g(x)dx,$$

we have that $\int_a^\infty g(x)dx$ is convergent. If $\int_a^\infty g(x)dx$ is convergent, then $(L + \varepsilon)\int_a^\infty g(x)dx$ and $(L + \varepsilon)\int_\delta^\infty g(x)dx$ are also convergent. Use the last inequality of 2.3 and theorem 36 to see that $\int_\delta^\infty f(x)dx$ is also convergent. Since

$$(2.4) \quad \int_a^\infty f(x)dx = \int_a^\delta f(x)dx + \int_\delta^\infty f(x)dx,$$

one has that $\int_a^\infty f(x)dx$ is convergent.

ii) If $L = 0$, in formula (2.3) we use only the last inequality to see that if $\int_a^\infty g(x)dx$ is convergent, then $\varepsilon\int_a^\infty g(x)dx$ and $\varepsilon\int_\delta^\infty g(x)dx$ are also convergent so $\int_\delta^\infty f(x)dx$ is convergent. From formula (2.4) we get that $\int_a^\infty f(x)dx$ itself is convergent.

iii) If $L = \infty$, then for any fixed $M > 0$, there exists a large number $\delta > a$ such that $\frac{f(x)}{g(x)} > M$ if $x \in [\delta, \infty)$. Since $f(x) > Mg(x)$, $x \in [\delta, \infty)$ and since $\int_a^\infty g(x)dx$ and $M\int_\delta^\infty g(x)dx$ are divergent, then $\int_\delta^\infty f(x)dx$ is divergent. Now we apply again formula (2.4) to see that $\int_a^\infty f(x)dx$ is divergent. \square

For instance, since

$$\lim_{x \rightarrow \infty} \frac{\frac{1}{\sqrt[3]{x^2+1}}}{\frac{1}{x^{\frac{2}{3}}}} = 1$$

and since $\int_1^\infty \frac{1}{x^{\frac{2}{3}}}dx$ is divergent ($\alpha = 2/3$ in example 47), this last theorem says that $\int_1^\infty \frac{1}{\sqrt[3]{x^2+1}}dx$ is divergent.

If in theorem 37 we take $a > 0$ and $g(x) = \frac{1}{x^p}$, we get a very useful test.

THEOREM 38. (test p) Let $f : [a, \infty) \rightarrow \mathbb{R}_+$ be a function defined on the interval $[a, \infty)$ with nonnegative values, integrable on any subinterval $[a, x] \subset [a, \infty)$. Let

$$\lim_{x \rightarrow \infty} x^p f(x) = L \in \mathbb{R} \cup \{\infty\}.$$

i) If $L \neq 0, \infty$ and $p > 1$, then $\int_a^\infty f(x)dx$ is convergent. If $L \neq 0, \infty$ and $p \leq 1$, then $\int_a^\infty f(x)dx$ is divergent.

ii) If $L = 0$ and $p > 1$, then $\int_a^\infty f(x)dx$ is convergent.

iii) If $L = \infty$ and $p \leq 1$, then $\int_a^\infty f(x)dx$ is divergent.

If $L \neq 0, \infty$, we call the number $k = -p$, Abel's degree of $f(x)$. For instance, Abel degree of $f(x) = x^3 + 1$ is equal to $k = 3$ because $\lim_{x \rightarrow \infty} x^{-3}(x^3 + 1) = 1$. The Abel degree is uniquely determined. Indeed, $\lim_{x \rightarrow \infty} x^p f(x) = \lim_{x \rightarrow \infty} x^{p'} f(x) = L \neq 0$ implies that $\lim_{x \rightarrow \infty} x^{p-p'} = 1$, or that $p = p'$.

Test p is very useful in apparently complicated problems. For instance, is it possible to use an approximation like this:

$$\int_0^\infty \frac{\sqrt{x+1} - \sqrt{x}}{\sqrt[3]{x^2+1}} dx \approx \int_0^{10000} \frac{\sqrt{x+1} - \sqrt{x}}{\sqrt[3]{x^2+1}} dx?$$

To find an elementary primitive of $\frac{\sqrt{x+1} - \sqrt{x}}{\sqrt[3]{x^2+1}}$ is not a good idea! Let us prove that this improper integral of the first type is convergent and then everything will be clear.

For this, let us use test p (see theorem 38):

$$\begin{aligned} \lim_{x \rightarrow \infty} x^p \frac{\sqrt{x+1} - \sqrt{x}}{\sqrt[3]{x^2+1}} &= \lim_{x \rightarrow \infty} \frac{x^p}{(\sqrt{x+1} + \sqrt{x}) \sqrt[3]{x^2+1}} = \\ &= \lim_{x \rightarrow \infty} \frac{x^p}{x^{\frac{1}{2}} \left(\sqrt{1 + \frac{1}{x}} + 1 \right) x^{\frac{2}{3}} \sqrt[3]{1 + \frac{1}{x^2}}} = \frac{1}{2} \lim_{x \rightarrow \infty} \frac{x^p}{x^{\frac{1}{2} + \frac{2}{3}}} \neq 0, \infty \end{aligned}$$

if and only if $p = \frac{7}{6}$, which is greater than 1. Thus, our integral is convergent (see theorem 38) and we can use that approximation. The approximate integral $\int_0^{10000} \frac{\sqrt{x+1} - \sqrt{x}}{\sqrt[3]{x^2+1}} dx$ is a Riemann integral and it can be easily approximated by one the usual method described in Chapter 1.

Except Cauchy criterion, all the other tests given above are about improper integrals of a nonnegative function. Here is a basic and useful test on improper integrals of functions which are not necessarily nonnegative.

THEOREM 39. (*Dirichlet's test*) Let f, g be two continuous functions defined on $[a, \infty)$ with values in \mathbb{R} . Assume that the Newton primitive function $F(x) = \int_a^x f(t)dt$ is bounded on $[a, \infty)$, i.e. there exists a number $M > 0$ such that $|F(x)| \leq M$ for any $x \in [a, \infty)$. We also assume that g is a function of class C^1 on $[a, \infty)$ and $\lim_{x \rightarrow \infty} g(x) = 0$. Then $\int_a^\infty f(x)g(x)dx$ is convergent.

PROOF. We simply apply the Cauchy criterion (see theorem 34).

$$\begin{aligned} \int_{x'}^{x''} f(x)g(x)dx &= \int_{x'}^{x''} F'(x)g(x)dx \stackrel{\text{by parts}}{=} F(x)g(x) \Big|_{x'}^{x''} - \\ &- \int_{x'}^{x''} F(x)g'(x)dx \stackrel{\text{mean formula}}{=} F(x'')g(x'') - F(x')g(x') - \\ &- F(c_{x',x''}) [g(x'') - g(x')], \text{ where } c_{x',x''} \in [x', x'']. \end{aligned}$$

Thus,

$$\begin{aligned} \left| \int_{x'}^{x''} f(x)g(x)dx \right| &\leq \\ &\leq |F(x'')g(x'')| + |F(x')g(x')| + |F(c_{x',x''})| [|g(x'')| + |g(x')|] \leq \\ (2.5) \end{aligned}$$

$$M [|g(x'')| + |g(x')|] + M [|g(x'')| + |g(x')|] = 2M [|g(x'')| + |g(x')|].$$

Take now a small $\varepsilon > 0$ and let $\delta > 0$ be large enough such that if $x \in [\delta, \infty)$ then $|g(x)| < \frac{\varepsilon}{4M}$. This is true because $\lim_{x \rightarrow \infty} g(x) = 0$. This δ is the searched for δ in Cauchy criterion:

$$\left| \int_{x'}^{x''} f(x)g(x)dx \right| \leq 2M [|g(x'')| + |g(x')|] < 2M \left[\frac{\varepsilon}{4M} + \frac{\varepsilon}{4M} \right] = \varepsilon,$$

if $x', x'' \in [\delta, \infty)$. \square

EXAMPLE 49. (*Dirichlet's integral*) If β is a real number, the following integral $\int_0^\infty \frac{\sin \beta x}{x} dx$ is called the *Dirichlet's integral*. We can assume that $\beta > 0$. Let us prove that this integral is convergent. First of all let us remark that the function $\frac{\sin \beta x}{x}$ defined initially only on $(0, \infty)$ can be extended to a continuous function

$$h(x) = \begin{cases} \frac{\sin \beta x}{x}, & \text{if } x \in (0, \infty) \\ \beta, & \text{if } x = 0, \end{cases}$$

defined on $[0, \infty)$. Thus, we can substitute the initial integral with $\int_0^\infty h(x)dx$. This last one is "identical" with the initial one because does not matter what we put in $x = 0$, the value of the integral does not change if that one is convergent. Since

$$\int_0^\infty \frac{\sin \beta x}{x} dx = \int_0^1 \frac{\sin \beta x}{x} dx + \int_1^\infty \frac{\sin \beta x}{x} dx,$$

it will be enough to prove that the last integral $\int_1^\infty \frac{\sin \beta x}{x} dx$ is convergent. In order to prove this we apply the *Dirichlet's test* by putting $f(x) = \sin \beta x$, which has the Newton's primitive $F(x) = \int_1^x \sin \beta t dt = \frac{\cos \beta}{\beta} - \frac{\cos \beta x}{\beta}$ bounded by $\frac{2}{\beta}$ on $[1, \infty)$, and $g(x) = \frac{1}{x}$, which is of class C^1 and

decreasing to 0 at ∞ . Hence the Dirichlet's integral is convergent for any fixed $\beta \in \mathbb{R}$.

EXAMPLE 50. (Fresnel's integrals) The following integrals

$I = \int_0^\infty \sin x^2 dx$ and $J = \int_0^\infty \cos x^2 dx$ are called the Fresnel's integrals. Let us prove that I is convergent (in fact both are convergent!). For this, let us write

$$\int_0^\infty \sin x^2 dx = \int_0^1 \sin x^2 dx + \int_1^\infty \sin x^2 dx.$$

It is enough to prove that $\int_1^\infty \sin x^2 dx$ is convergent. Let us denote $F(x) = \int_1^x \sin t^2 dt$ and let us change the variable $t = \sqrt{u}$. So

$$\int_1^x \sin t^2 dt = \frac{1}{2} \int_1^{x^2} \frac{1}{\sqrt{u}} \sin u du.$$

Since any real number $z \in [1, \infty)$ can be written as $z = x^2$ for an $x \in [1, \infty)$, it is enough to see that the integral $\int_1^\infty \frac{1}{\sqrt{u}} \sin u du$ is convergent. Here we apply again the Dirichlet's test for $f(u) = \sin u$ and $g(u) = \frac{1}{\sqrt{u}}$. So the first Fresnel's integral is convergent. We leave as an exercise for the reader to prove (in the same way!) that the second Fresnel's integral is also convergent.

3. Improper integrals of the second type

Let $f : [a, b] \rightarrow \mathbb{R}$ be a (Riemann) integrable function on the closed and bounded interval $[a, b]$. Theorem 13 says that in this case f must be a bounded function, i.e. there exists a real number $M > 0$ such that $|f(x)| \leq M$ for any $x \in [a, b]$. The next result tries to say something on the reverse statement.

THEOREM 40. Let $f : [a, b) \rightarrow \mathbb{R}$ be a bounded function on the interval $[a, b)$ which is integrable on any closed subinterval $[a, x]$, where $x \in [a, b)$. Then f is integrable on the entire interval $[a, b]$ and

$$(3.1) \quad \int_a^b f(x) dx = \lim_{x \rightarrow b, x < b} \int_a^x f(t) dt.$$

If f is integrable on any subinterval $[y, b]$, where $y \in (a, b]$, then again f is integrable on the entire interval $[a, b]$ and

$$(3.2) \quad \int_a^b f(x) dx = \lim_{y \rightarrow a, y > a} \int_y^b f(t) dt$$

PROOF. Since the proof for the second part of the statement is very similar to the proof of the first part, we shall prove only this last one. To prove the integrability of f on $[a, b]$ we shall use Darboux Criterion (theorem 14). Since f is bounded on $[a, b]$ one can choose $M > 0$ such that $|f(x)| \leq M$ on $[a, b]$. Let $\varepsilon > 0$ be a small positive real number and let $\delta_1 = \varepsilon/2M$. Let $\delta > 0$ such that $\delta \leq \delta_1$ and for any partition $\Delta = \{a = x_0, x_1, \dots, x_{n-1} = b - \delta_1\}$ of the interval $[a, b - \delta_1]$ with $\|\Delta\| < \delta$, one has:

$$S_\Delta - s_\Delta = \sum_{i=1}^{n-1} (M_i - m_i)(x_i - x_{i-1}) < \varepsilon/2.$$

Here $M_i = \sup_{x \in [x_{i-1}, x_i]} f(x)$ and $m_i = \inf_{x \in [x_{i-1}, x_i]} f(x)$. Let us consider now the partition

$$(3.3) \quad \Delta' = \{a = x_0, x_1, \dots, x_{n-1}, x_n = b\} = \Delta \cup \{b\}$$

of the interval $[a, b]$. If we keep the above δ fixed, any partition Δ'' of $[a, b]$, $\|\Delta''\| < \delta$, can be represented as a partition Δ' like in formula (3.3), with a $\delta'_1 \leq \delta_1$, instead of δ_1 . Thus

$$S_{\Delta'} - s_{\Delta'} \leq S_\Delta - s_\Delta + (M_n - m_n)\delta_1 \leq \varepsilon/2 + M \cdot \varepsilon/2M = \varepsilon.$$

Applying Darboux Criterion we get that f is integrable and

$$\begin{aligned} \int_a^b f(x)dx &= \lim_{\|\Delta'\| \rightarrow 0} S_{\Delta'} = \lim_{\|\Delta\| \rightarrow 0} S_\Delta = \\ &= \lim_{\delta_1 \rightarrow 0} \int_a^{b-\delta_1} f(x)dx = \lim_{x \rightarrow b, x < b} \int_a^x f(t)dt. \end{aligned}$$

□

For instance, applying this last result we find that the noncontinuous function $f : [0, 1] \rightarrow \mathbb{R}$,

$$f(x) = \begin{cases} x, & \text{if } x \in [0, 1) \\ 2, & \text{if } x = 1 \end{cases},$$

is integrable and

$$\int_0^1 f(x)dx = \lim_{x \rightarrow 1, x < 1} \int_0^x tdt = \lim_{x \rightarrow 1, x < 1} \frac{x^2}{2} = \frac{1}{2}.$$

We say that a function $f : I \rightarrow \mathbb{R}$, defined on an interval I with real values is *unbounded at a limit point b of I* if there exists at least one sequence $\{x_n\}$ with $x_n \in I$, $x_n \rightarrow b$ such that the sequence $\{f(x_n)\}$ is not bounded. For instance, $f(x) = 1/x$, $x \in (0, 1]$ is not bounded at 0. We also say that 0 is a *singular point for f* . We can also write

$\lim_{x \rightarrow 0, x > 0} \frac{1}{x} = \infty$, thus $f(x) = 1/x$ is not bounded at 0. In our definition we can take $x_n = 1/n$.

DEFINITION 11. Let $[a, b]$ be a bounded and closed interval in \mathbb{R} and let $f : [a, b) \rightarrow \mathbb{R}$ such that f is integrable on any subinterval $[a, x]$, $x \in [a, b)$ and f is unbounded at b . We say that f is integrable on $[a, b]$ if the following limit $\lim_{x \rightarrow b, x < b} \int_a^x f(t) dt$ exists, is finite and in this case we denote it by $\int_a^b f(t) dt$. This last integral is called an improper integral of the second type with singularity at b . We also say that the integral $\int_a^b f(t) dt$ is convergent.

EXERCISE 7. Let $f : (a, b] \rightarrow \mathbb{R}$ be an integrable function on any interval $[x, b]$, $x \in (a, b]$ such that f is unbounded at a . Define the convergence of $\int_a^b f(t) dt$ in this last case.

For instance, $f(x) = 1/x$, $x \in (0, 1]$ is unbounded at 0 and $\int_0^1 \frac{1}{x} dx$ is divergent because

$$\lim_{x \rightarrow 0, x > 0} \int_x^1 \frac{1}{t} dt = \lim_{x \rightarrow 0, x > 0} [\ln 1 - \ln x] = \infty.$$

But $\int_0^1 \frac{1}{\sqrt{x}} dx$ is convergent because

$$\lim_{x \rightarrow 0, x > 0} \int_x^1 \frac{1}{\sqrt{t}} dt = \lim_{x \rightarrow 0, x > 0} \left. 2t^{\frac{1}{2}} \right|_x^1 = \lim_{x \rightarrow 0, x > 0} [2 - 2x^{\frac{1}{2}}] = 2.$$

If f is unbounded at an interior point c of $[a, b]$ but all the integrals $\int_a^x f(t) dt$, $x > a$, $x < c$ and $\int_y^b f(t) dt$, $y > c$, $y < b$ exist, then, by definition, $\int_a^b f(x) dx$ exists (is convergent) if both improper integrals of the second type $\int_a^c f(x) dx$ and $\int_c^b f(x) dx$ exist (are convergent). In this last case we write

$$\int_a^b f(x) dx = \int_a^c f(x) dx + \int_c^b f(x) dx.$$

For instance, $I = \int_{-1}^1 \frac{1}{\sqrt[3]{x}} dx$ is convergent because both integrals $I_1 = \int_{-1}^0 \frac{1}{\sqrt[3]{x}} dx$ and $I_2 = \int_0^1 \frac{1}{\sqrt[3]{x}} dx$ are convergent. Indeed,

$$\lim_{x \rightarrow 0, x < 0} \int_{-1}^x \frac{1}{\sqrt[3]{t}} dt = \lim_{x \rightarrow 0, x < 0} \left[\frac{3}{2} x^{\frac{2}{3}} - \frac{3}{2} \right] = -\frac{3}{2},$$

and

$$\lim_{x \rightarrow 0, x > 0} \int_x^1 \frac{1}{\sqrt[3]{t}} dt = \lim_{x \rightarrow 0, x > 0} \left[\frac{3}{2} - \frac{3}{2} x^{\frac{2}{3}} \right] = \frac{3}{2}.$$

Thus, $I = I_1 + I_2 = 0$.

In the case when at least one of the integrals $\int_a^c f(x)dx$ or $\int_c^b f(x)dx$ is divergent (nonconvergent) one can define the principal value of

$$\int_a^b f(x)dx$$

by the following formula

$$pv \int_a^b f(x)dx \stackrel{def}{=} \lim_{\varepsilon \rightarrow 0, \varepsilon > 0} \left[\int_a^{c-\varepsilon} f(x)dx + \int_{c+\varepsilon}^b f(x)dx \right].$$

If this last limit exists, in practice one can work with it, but,...very carefully, because its value is only a convention.

For instance, $\int_{-1}^1 \frac{1}{x}dx$ is divergent because neither $\int_{-1}^0 \frac{1}{x}dx$, nor $\int_0^1 \frac{1}{x}dx$ is convergent.

However, the principal value of $\int_{-1}^1 \frac{1}{x}dx$ is 0. Indeed,

$$\begin{aligned} \int_{-1}^1 \frac{1}{x}dx &= \lim_{\varepsilon \rightarrow 0, \varepsilon > 0} \left[\int_{-1}^{-\varepsilon} \frac{1}{x}dx + \int_{\varepsilon}^1 \frac{1}{x}dx \right] = \\ &= \lim_{\varepsilon \rightarrow 0, \varepsilon > 0} [\ln \varepsilon - \ln 1 + \ln 1 - \ln \varepsilon] = 0. \end{aligned}$$

To use in practice the definition 11 is usually a very difficult task because we must compute integrals of the type $\int_a^x f(t)dt$. In practical problems we want to know if our improper integral of the second type $\int_a^b f(x)dx$ with singularity at b is convergent or not. If it is convergent, then we can approximate it with $\int_a^{b-\varepsilon} f(x)dx$ for a very small chosen positive number ε . For instance, $\varepsilon = 10^{-6}$. Now, to compute this last Riemann integral $\int_a^{b-\varepsilon} f(x)dx$ one can use any approximate formula just studied in Chapter 2. To decide the convergence of an improper integral of the second type $\int_a^b f(x)dx$ with singularity at b , we need some "tests".

We begin with a standard example.

EXAMPLE 51. Let $I(\alpha) = \int_a^b \frac{1}{(b-x)^\alpha}dx$ be an improper integral of the second type with singularity at b , where α is a fixed positive real number. Let us prove that our integral is convergent if and only if $\alpha < 1$. Indeed,

$$(3.4) \quad I(\alpha) = \lim_{x \rightarrow b, x < b} \int_a^x \frac{1}{(b-t)^\alpha} dt.$$

But

$$\int_a^x \frac{1}{(b-t)^\alpha} dt = -\frac{(b-x)^{-\alpha+1}}{-\alpha+1} + \frac{(b-a)^{-\alpha+1}}{-\alpha+1},$$

if $\alpha \neq 1$, and

$$\int_a^x \frac{1}{(b-t)^\alpha} dt = \ln \frac{b-a}{b-x},$$

if $\alpha = 1$. It is easy to see that the limit in (3.4) exists if and only if $\alpha < 1$. In this last case $I(\alpha) = \frac{(b-a)^{-\alpha+1}}{-\alpha+1}$.

If $F(x) = \int_a^x f(t)dt$, $x \in [a, b)$ is the area function of Newton for function f which appears in the last definition, then $\int_a^b f(t)dt$ is convergent if and only if the function $F : [a, b) \rightarrow \mathbb{R}$ has a (unique) finite limit at the point b . Thus we can apply the general Cauchy Criterion (see theorem 31, a)) for the function F and obtain:

THEOREM 41. (*Cauchy criterion for improper integrals II*) Let $f : [a, b) \rightarrow \mathbb{R}$ be a function which is integrable on any finite interval $[a, x]$ for $x \in [a, b)$. Then $\int_a^b f(x)dx$ is convergent if and only if for any small $\varepsilon > 0$, there exists δ small enough and depending on ε , such that if $x', x'' \in (b - \delta, b)$, then $\left| \int_{x'}^{x''} f(x)dx \right| < \varepsilon$. This is equivalent to say that $\int_{x'}^{x''} f(x)dx \rightarrow 0$, whenever $x', x'' \rightarrow b$, $x', x'' \in [a, b)$ and $x', x'' < b$.

EXAMPLE 52. Let us apply this last Cauchy criterion to see if the improper integral of the second type $\int_1^2 \frac{\sin x}{\sqrt{x-1}} dx$ is convergent or not. Here $x = 1$ is the unique singularity of $f(x) = \frac{\sin x}{\sqrt{x-1}}$ on $(1, 2]$. Take an $\varepsilon > 0$ and let us evaluate the quantity $\left| \int_{x'}^{x''} \frac{\sin x}{\sqrt{x-1}} dx \right|$. Using the mean formula (see theorem 22), we get

$$\int_{x'}^{x''} \frac{\sin x}{\sqrt{x-1}} dx = \sin c \int_{x'}^{x''} \frac{1}{\sqrt{x-1}} dx.$$

Thus,

$$\left| \int_{x'}^{x''} \frac{\sin x}{\sqrt{x-1}} dx \right| \leq 2\sqrt{x''-1} + 2\sqrt{x'-1} < \varepsilon,$$

if $x', x'' \in (1, 1 + \delta)$, with $\delta = \frac{\varepsilon^2}{16}$. Here a neighborhood of 1 in $(1, 2]$ is of the form $(1, 1 + \delta)$, with δ small enough.

The similarity with the improper integrals of the first type is now very clear. Indeed, it is enough to put instead of ∞ , the real number b and instead of the neighborhood (δ, ∞) of infinite, with δ large enough, the "neighborhood" $(b - \delta, b) = [a, b) \cap (b - \delta, b + \delta)$ of b in $A = [a, b)$. Even the other results relative to improper integrals of the first type can be transferred almost word by word for improper integrals of the second type, to be clear, we prefer to present them here with proofs.

Cauchy criterion is very used to derive other more useful in practice tests. In many cases the following test reduces the study of the improper integrals of the second type $\int_a^b f(x)dx$, with singularity at b , to the case of the nonnegative function $|f(x)|$. If the integral $\int_a^b |f(x)| dx$ is convergent, we say that $\int_a^b f(x)dx$ is *absolutely convergent*.

THEOREM 42. (*absolute convergence implies convergence*) Suppose that the integral of the second type, $\int_a^b f(x)dx$, with singularity at b , is *absolutely convergent*. Then it is also convergent.

PROOF. Since $\int_a^b f(x)dx$ is absolutely convergent, one has that the integral $\int_a^b |f(x)| dx$ is convergent thus, by using Cauchy criterion, we have that

$$\left| \int_{x'}^{x''} |f(x)| dx \right| \rightarrow 0,$$

whenever $x', x'' \rightarrow b$. Since

$$\left| \int_{x'}^{x''} f(x)dx \right| \leq \left| \int_{x'}^{x''} |f(x)| dx \right|,$$

one has that $\left| \int_{x'}^{x''} f(x)dx \right| \rightarrow 0$, whenever $x', x'' \rightarrow b$, i.e. our integral $\int_a^\infty f(x)dx$ is also convergent. \square

For instance, let us use this last result to prove that the integral $I = \int_0^1 \frac{\sin(\sqrt[4]{x})}{\sqrt{x}} dx$, with the unique singularity $x = 0$, is convergent. We shall prove that it is absolutely convergent. Indeed,

$$\int_{x'}^{x''} \frac{|\sin(\sqrt[4]{x})|}{\sqrt{x}} dx \leq \left| \int_{x'}^{x''} \frac{1}{\sqrt{x}} dx \right| = \left| 2\sqrt{x''} - 2\sqrt{x'} \right| \rightarrow 0,$$

when x' and x'' go to 0. Applying again Cauchy criterion, we get that the integral I is absolutely convergent.

Thus, first of all we give some criteria for improper integrals of the second type of nonnegative functions.

THEOREM 43. (*comparison test 1*) Let $f, g : [a, b) \rightarrow \mathbb{R}_+$ be two functions defined on the interval $[a, b)$ with nonnegative values, integrable on any subinterval $[a, x] \subset [a, b)$, unbounded at b and such that $f(x) \leq g(x)$ for any $x \in [a, b)$. i) If $\int_a^b g(x)dx$ is convergent, then $\int_a^b f(x)dx$ is also convergent. ii) If $\int_a^b f(x)dx$ is divergent, then $\int_a^b g(x)dx$ is also divergent.

PROOF. We apply Cauchy criterion in both cases. i) If $\int_a^b g(x)dx$ is convergent, then

$$\left| \int_{x'}^{x''} g(x)dx \right| \rightarrow 0,$$

when $x', x'' \rightarrow b$, where $x', x'' \in [a, b)$. But

$$\left| \int_{x'}^{x''} f(x)dx \right| \leq \left| \int_{x'}^{x''} g(x)dx \right| \rightarrow 0,$$

so $\left| \int_{x'}^{x''} f(x)dx \right| \rightarrow 0$, whenever $x', x'' \rightarrow b$. Hence $\int_a^b f(x)dx$ is convergent.

ii) If $\int_a^b g(x)dx$ were convergent, from i) we would have that $\int_a^b f(x)dx$ is convergent, a contradiction. So $\int_a^b g(x)dx$ must be divergent. \square

For instance, since

$$\frac{1}{\sqrt{x}(1+x)} < \frac{1}{\sqrt{x}}, \text{ for any } x \in (0, 1],$$

and since $\int_0^1 \frac{1}{\sqrt{x}}dx$ is convergent ($\alpha = 1/2 < 1$ in example 51), this last theorem tells us that $\int_0^1 \frac{1}{\sqrt{x}(1+x)}dx$ is convergent.

THEOREM 44. (*limit comparison test*) Let $f, g : [a, b) \rightarrow \mathbb{R}_+$ be two functions defined on the interval $[a, b)$ with nonnegative values, with b as the unique singularity and integrable on any subinterval $[a, x] \subset [a, b)$. Assume in addition that $g(x) > 0$ for any $x \in [a, b)$ and that the following limit "exists": $\lim_{x \rightarrow b} \frac{f(x)}{g(x)} = L \in \mathbb{R} \cup \{\infty\}$.

i) If $L \neq 0, \infty$, then the improper integrals $\int_a^b f(x)dx$ and $\int_a^b g(x)dx$ have the same nature, i.e. they are simultaneously convergent or divergent.

ii) If $L = 0$ and $\int_a^b g(x)dx$ is convergent, then $\int_a^b f(x)dx$ is also convergent.

iii) If $L = \infty$ and $\int_a^b g(x)dx$ is divergent, then $\int_a^b f(x)dx$ is also divergent.

PROOF. i) Take an $\varepsilon > 0$ sufficiently small such that $L - \varepsilon > 0$ (since f and g have nonnegative values, L is nonnegative). Since $\lim_{x \rightarrow b} \frac{f(x)}{g(x)} = L$, there exists a small enough $\delta > 0$ such that $a < b - \delta$ and if $x \in [b - \delta, b)$, then

$$L - \varepsilon < \frac{f(x)}{g(x)} < L + \varepsilon,$$

or

$$(3.5) \quad (L - \varepsilon)g(x) < f(x) < (L + \varepsilon)g(x).$$

If $\int_a^b f(x)dx$ is convergent, then $\int_{b-\delta}^b f(x)dx$ and $\int_{b-\delta}^b \frac{f(x)}{L-\varepsilon}dx$ are also convergent; since $g(x) < \frac{f(x)}{L-\varepsilon}$, one has that $\int_{b-\delta}^b g(x)dx$ is also convergent (see theorem 43). Since

$$\int_a^b g(x)dx = \int_a^{b-\delta} g(x)dx + \int_{b-\delta}^b g(x)dx,$$

we have that $\int_a^b g(x)dx$ is convergent. If $\int_a^b g(x)dx$ is convergent, then $(L + \varepsilon)\int_a^b g(x)dx$ and $(L + \varepsilon)\int_{b-\delta}^b g(x)dx$ are also convergent. Use the last inequality of (3.5) and theorem 43 to see that $\int_{b-\delta}^b f(x)dx$ is convergent. Since

$$(3.6) \quad \int_a^b f(x)dx = \int_a^{b-\delta} f(x)dx + \int_{b-\delta}^b f(x)dx,$$

one has that $\int_a^b f(x)dx$ is convergent.

ii) If $L = 0$, in formula (3.5) we use only the last inequality to see that if $\int_a^b g(x)dx$ is convergent, then $\varepsilon\int_a^b g(x)dx$ and $\varepsilon\int_{b-\delta}^b g(x)dx$ are also convergent and $\int_{b-\delta}^b f(x)dx$ is convergent. From formula (3.6) we get that $\int_a^b f(x)dx$ itself is convergent.

iii) If $L = \infty$, then for any fixed $M > 0$, there exists a small number $\delta > 0$ such that $\frac{f(x)}{g(x)} > M$ if $x \in [b - \delta, b)$. Since $f(x) > Mg(x)$, $x \in [b - \delta, b)$ and since $\int_a^b g(x)dx$ and $M\int_{b-\delta}^b g(x)dx$ are divergent, then $\int_{b-\delta}^b f(x)dx$ is also divergent. Now we apply again formula (3.6) to see that $\int_a^b f(x)dx$ is divergent. \square

For instance, since

$$\lim_{x \rightarrow 0, x > 0} \frac{\frac{1}{\sqrt{x(x+1)}}}{\frac{1}{\sqrt{x}}} = 1$$

and since $\int_0^2 \frac{1}{\sqrt{x}}dx$ is convergent ($\alpha = 1/2 < 1$ in example 51), this last theorem says that $\int_0^2 \frac{1}{\sqrt{x(x+1)}}dx$ is convergent.

If in theorem 44 we take $g(x) = \frac{1}{(b-x)^q}$, we get a very useful test.

THEOREM 45. (test q) Let $f : [a, b) \rightarrow \mathbb{R}_+$ be a function defined on the interval $[a, b)$ with nonnegative values, with the unique singularity

b and integrable on any subinterval $[a, x] \subset [a, \infty)$. Let

$$\lim_{x \rightarrow b, x < b} (b - x)^q f(x) = L \in \mathbb{R} \cup \{\infty\}.$$

i) If $L \neq 0, \infty$ and $q < 1$, then $\int_a^b f(x) dx$ is convergent.

ii) If $L = 0$ and $q < 1$, then $\int_a^b f(x) dx$ is also convergent.

iii) If $L = \infty$ and $q \geq 1$, then $\int_a^b f(x) dx$ is divergent.

Test q is very useful in apparently complicated problems. For instance, is it possible to use an approximation like this:

$$\int_0^1 \frac{\sqrt{x^3 + 3}}{\sqrt[5]{1-x}} dx \approx \int_0^{0.99999} \frac{\sqrt{x^3 + 3}}{\sqrt[5]{1-x}} dx?$$

To find an elementary primitive of $\frac{\sqrt{x^3+3}}{\sqrt[5]{1-x}}$ is not a good idea! Let us prove that this improper integral of the second type is convergent and then everything will be clear (see definition 11).

For this, let us use test q (see theorem 45):

$$\lim_{x \rightarrow 1, x < 1} (1-x)^q \frac{\sqrt{x^3+3}}{\sqrt[5]{1-x}} = L \neq 0, \infty$$

if and only if $q = \frac{1}{5}$. Then $L = 2$. Since $q = 1/5$, test q says that our integral $\int_0^1 \frac{\sqrt{x^3+3}}{\sqrt[5]{1-x}} dx$ is convergent and so we can use the indicated approximation. The approximate integral $\int_0^{0.99999} \frac{\sqrt{x^3+3}}{\sqrt[5]{1-x}} dx$ is a Riemann integral and it can be easily approximated by one the usual method described in Chapter 2.

Except the Cauchy criterion, all the other tests given above are about improper integrals of a nonnegative function. Here is a basic and useful test on improper integrals of functions which are not necessarily nonnegative.

THEOREM 46. (*Dirichlet's test*) Let f, g be two continuous functions defined on $[a, b)$ with values in \mathbb{R} . Suppose that f and g are unbounded at b . Assume that the Newton primitive function $F(x) = \int_a^x f(t) dt$ is bounded on $[a, b)$, i.e. there exists a number $M > 0$ such that $|F(x)| \leq M$ for any $x \in [a, b)$. We also assume that g is a function of class C^1 on $[a, b)$ and $\lim_{x \rightarrow b} g(x) = 0$. Then $\int_a^b f(x)g(x) dx$ is convergent.

PROOF. We simply apply Cauchy criterion (see theorem 41).

$$\int_{x'}^{x''} f(x)g(x) dx = \int_{x'}^{x''} F'(x)g(x) dx \stackrel{\text{by parts}}{=} F(x)g(x) \Big|_{x'}^{x''} -$$

$$- \int_{x'}^{x''} F(x)g'(x)dx \stackrel{\text{mean formula}}{=} F(x'')g(x'') - F(x')g(x') - F(c_{x',x''}) [g(x'') - g(x')], \text{ where } c_{x',x''} \in [x', x''].$$

Thus,

$$\left| \int_{x'}^{x''} f(x)g(x)dx \right| \leq \\ \leq |F(x'')g(x'')| + |F(x')g(x')| + |F(c_{x',x''})| [|g(x'')| + |g(x')|] \leq \\ (3.7)$$

$$M [|g(x'')| + |g(x')|] + M [|g(x'')| + |g(x')|] = 2M [|g(x'')| + |g(x')|].$$

Take now a small $\varepsilon > 0$ and let $\delta > 0$ be small enough such that if $x \in [b - \delta, b)$ then $|g(x)| < \frac{\varepsilon}{4M}$. This is true because $\lim_{x \rightarrow b} g(x) = 0$. This δ is the searched for δ in the Cauchy criterion:

$$\left| \int_{x'}^{x''} f(x)g(x)dx \right| \leq 2M [|g(x'')| + |g(x')|] < 2M \left[\frac{\varepsilon}{4M} + \frac{\varepsilon}{4M} \right] = \varepsilon,$$

if $x', x'' \in [b - \delta, b)$. \square

Let us use this last theorem to decide if one can approximate the improper integral of the second type, $\int_0^1 \frac{\sin \sqrt[3]{1-x}}{\sqrt{1-x}} dx$, with singularity at 1 (why?), by the usual Riemann integral $\int_0^{0.99999} \frac{\sin \sqrt[3]{1-x}}{\sqrt{1-x}} dx$. This last one can be approximately computed by using one of the methods described in Chapter 2. Thus we must show that the integral $\int_0^1 \frac{\sin \sqrt[3]{1-x}}{\sqrt{1-x}} dx$ is convergent. Let us use the above Dirichlet's test. For this we take $f(x) = \frac{1}{\sqrt{1-x}}$ and $g(x) = \sin \sqrt[3]{1-x}$. A primitive of f is $F(x) = -2\sqrt{1-x}$, which is bounded on $[0, 2)$ ($|F(x)| \leq 2$). Since g is decreasing to 0 when $x \rightarrow 1$, Dirichlet's test tells us that the integral is convergent.

Sometimes an improper integral can be a "combination" between improper integrals of the first type and improper integrals of the second type, i.e. mixed improper integrals. For instance, let us see if the integral $I = \int_1^\infty \frac{1}{(x^2+1)\sqrt[3]{x-1}} dx$ is convergent or not. Here the integration interval is unbounded and the integrand function is also unbounded at $x = 1$. Take a $\lambda > 1$ and write formally:

$$I = \int_1^\infty \frac{1}{(x^2+1)\sqrt[3]{x-1}} dx = \int_1^\lambda \frac{1}{(x^2+1)\sqrt[3]{x-1}} dx + \\ + \int_\lambda^\infty \frac{1}{(x^2+1)\sqrt[3]{x-1}} dx.$$

The first integral in sum is an improper integral of the second type. We can use test q for $q = 1/3 < 1$ to prove that it is convergent. The second integral in the above sum is an improper integral of the first type. It is also convergent because we can apply test p for $p = 2 + 1/3 = 7/3 > 1$. Their sum will be by definition the value of I . It is easy to see that this value does not depend on the choice of $\lambda > 1$. Such an integral I is also called an improper integral. We must be very carefully with the operations with improper integrals. For instance a sum between a convergent integral and a divergent one is always a divergent integral. But, a sum between two divergent integrals is not always divergent as the following example shows. Let $I = \int_0^\infty (\sin x - \sin x) dx = 0$, but both $I_1 = \int_0^\infty \sin x dx$ and $I_2 = \int_0^\infty (-\sin x) dx$ are divergent. Thus, the decomposition $I = I_1 + I_2$ has no meaning at all!

We end this chapter with a more sophisticated example.

EXAMPLE 53. Let us see if the following integral $I = \int_0^\infty \frac{\sin x}{\sqrt{x+\sin x}} dx$ exists, i.e. if it is convergent. Let us see what happens on the interval $[0, \infty)$ with function $f(x) = \frac{\sin x}{\sqrt{x+\sin x}}$. It is easy to see that this function could be unbounded only at $x = 0$. But

$$\lim_{x \rightarrow 0, x > 0} \frac{\sin x}{\sqrt{x + \sin x}} = \lim_{x \rightarrow 0, x > 0} \frac{x - \frac{x^3}{3!} + \dots}{\sqrt{x + x - \frac{x^3}{3!} + \dots}} = 0,$$

so that our function is bounded on $[0, \infty)$ and the integral is an improper integral of the first type, i.e. it has a singularity only at ∞ . Let us write

$$I = I_1 + I_2,$$

where $I_1 = \int_0^2 \frac{\sin x}{\sqrt{x+\sin x}} dx$ and $I_2 = \int_2^\infty \frac{\sin x}{\sqrt{x+\sin x}} dx$. In order to prove that I is convergent (divergent) it is enough to prove that I_2 is convergent (divergent) because I_1 is a proper integral, i.e. an usual Riemann integral on $[0, 2]$. And any proper integral is convergent! Let us write now

$$\frac{\sin x}{\sqrt{x + \sin x}} = \frac{\sin x}{\sqrt{x}} - \frac{\sin^2 x}{\sqrt{x}(\sqrt{x + \sin x})}.$$

Applying Dirichlet's test (theorem 39) to the integral $\int_2^\infty \frac{\sin x}{\sqrt{x}} dx$ we get that this one is convergent. Thus the nature of the integral I_2 is the same like the nature of the integral $\int_2^\infty \frac{\sin^2 x}{\sqrt{x}(\sqrt{x+\sin x})} dx$. But this time the integrand function $\frac{\sin^2 x}{\sqrt{x}(\sqrt{x+\sin x})}$ is nonnegative and we can compare it with an easier nonnegative function $g(x) = \frac{\sin^2 x}{\sqrt{x}(\sqrt{x+1})} \leq f(x) = \frac{\sin^2 x}{\sqrt{x}(\sqrt{x+\sin x})}$. It is enough to prove that $\int_2^\infty \frac{\sin^2 x}{\sqrt{x}(\sqrt{x+1})} dx$ is divergent to

conclude that $\int_2^\infty \frac{\sin^2 x}{\sqrt{x}(\sqrt{x}+\sin x)} dx$ is divergent and so I_2 would be divergent. Since the integral

$$-\frac{1}{2} \int_2^\infty \frac{1-2\sin^2 x}{\sqrt{x}(\sqrt{x}+1)} dx = -\frac{1}{2} \int_2^\infty \frac{\cos 2x}{\sqrt{x}(\sqrt{x}+1)} dx$$

is convergent (apply again Dirichlet's test) and since the integral

$$\frac{1}{2} \int_2^\infty \frac{1}{\sqrt{x}(\sqrt{x}+1)} dx \text{ is divergent (apply test } p \text{ for } p=1), \text{ from}$$

$$\int_2^\infty \frac{\sin^2 x}{\sqrt{x}(\sqrt{x}+1)} dx = -\frac{1}{2} \int_2^\infty \frac{1-2\sin^2 x}{\sqrt{x}(\sqrt{x}+1)} dx + \frac{1}{2} \int_2^\infty \frac{1}{\sqrt{x}(\sqrt{x}+1)} dx,$$

we conclude that the integral $\int_2^\infty \frac{\sin^2 x}{\sqrt{x}(\sqrt{x}+1)} dx$ is divergent. Thus I_2 and I are also divergent. This information is very important because it will be a crazy idea to approximate with something a divergent integral. You can say "maybe the given integral has something wrong in its form if somebody insists to compute it!". For instance, if instead of \sqrt{x} one put $\sqrt[4]{x^3}$ the new obtained integral $\int_0^\infty \frac{\sin x}{\sqrt[4]{x^3}+\sin x} dx$ were convergent (prove this following the same steps as above!).

We saw that there is a close connection between the improper integrals of the first type and the numerical series (see theorem 33). One has an analogous result for the improper integrals of the second type.

THEOREM 47. (series test 1) *Let us consider the improper integral of the second type $I = \int_a^b f(x) dx$, with the unique singularity at the point b . We also assume that f is continuous on $[a, b)$. Let us take a sequence $a = b_0 < b_1 < \dots < b_n < \dots < b$ such that $b_n \rightarrow b$ and let us consider the numerical series $S = \sum_{n=0}^\infty u_n$, where $u_n = \int_{b_n}^{b_{n+1}} f(x) dx$. Then, if the integral I is convergent, the series S is also convergent and $S = I$. Moreover, if in addition f has nonnegative values on $[a, b)$, then the converse statement is also true. Namely, if the series S is convergent, then the integral I is also convergent and $I = S$.*

We leave the proof of this theorem as an exercise for the reader. What happens with the above result if $b = \infty$. For instance, in order to compute the series $-2 \sum_{n=1}^\infty \left[\frac{1}{\sqrt{n+1}} - \frac{1}{\sqrt{n}} \right]$, one take the function $f(x) = \frac{1}{\sqrt{1-x}}$ and compute $\int_0^1 f(x) dx = 2$. Hence the series is convergent and its sum is equal to 2. Here we take $b_n = 1 - \frac{1}{n}$, etc.

Can we reduce the study and the computation of an improper integral of the second type $\int_a^b f(x) dx$ with the unique singularity at b to an improper integral of the first type? The answer is yes! Let us take a small arbitrary number $\delta > 0$ and let us perform the change of

variables: $t = \frac{1}{b-x}$, $x = b - \frac{1}{t}$, in the integral $I(\delta) = \int_a^{b-\delta} f(x)dx$. Thus $I(\delta) = \int_{\frac{1}{b-a}}^{\frac{1}{b-a-\delta}} f\left(b - \frac{1}{t}\right) \cdot \frac{1}{t^2} dt$. Let us denote by $g(t)$ the new function of t , $\frac{f(b-\frac{1}{t})}{t^2}$. Since $\lim_{\delta \rightarrow 0} I(\delta)$ is the same with $\lim_{u \rightarrow \infty} \int_{\frac{1}{b-a}}^u g(t)dt$, the study of $\int_a^b f(x)dx$ was reduced to the study of $\int_{\frac{1}{b-a}}^{\infty} g(t)dt$. We leave as an exercise to the reader to prove the test q by using this last reduction and the test p .

Here is a last remark which is useful in the following chapter where we need to consider improper integrals of both types at the same time.

REMARK 17. Let b be a real number or ∞ ($b \in \mathbb{R} \cup \{\infty\}$) and let a a any fixed real number less than b . If $[a, b)$ is the obviously defined interval we say that V is a fundamental neighborhood of b in $[a, b)$ if V is of the form $(b - \delta, b)$, δ being any small nonnegative real number with $0 < \delta < b - a$, for $b \neq \infty$ and $V = (M, \infty)$ with any $M > a$ for $b = \infty$. Let $f : [a, b) \rightarrow \mathbb{R}$ be a function defined on $[a, b)$ with real values such that it is (Riemann) integrable on any subinterval $[a, c]$ with $a < c < b$. We say that b is the unique singular point of f if either $b = \infty$ and f is bounded at any point $c \in [a, \infty)$, or $b \neq \infty$ and f is unbounded at b and bounded at any other point $c \in [a, b)$. Let f be as above with the unique singularity at b . The integral $\int_a^b f(x)dx$ is called a (simple) improper integral. It is convergent if and only if the limit $\lim_{x \rightarrow b, x > a} \int_a^x f(t)dt$ exists. Its value is called the value of the improper integral $\int_a^b f(x)dx$. All the other results which were given when we separately discussed improper integrals of the first and of the second type can be reformulated in language of improper integrals defined like in this remark. For instance, Cauchy criterion says that $\int_a^b f(x)dx$ is convergent if and only if for any small $\varepsilon > 0$, there exists a fundamental neighborhood V_ε of b in $[a, b)$ such that whenever $x', x'' \in V_\varepsilon$ one has that $\left| \int_{x'}^{x''} f(x)dx \right| < \varepsilon$. We invite the reader to check that this last criterion is equivalent to each one of the Cauchy criterions given for the particular situations: $b = \infty$ and $b \neq \infty$. We also leave as an exercise for the reader to state the general form of the Dirichlet's criterion for the general definition given here in this remark.

By a proper integral we mean an usual Riemann integral $\int_a^b f(x)dx$, where $f : [a, b] \rightarrow \mathbb{R}$ is an integrable function on $[a, b] \subset \mathbb{R}$. Here the function f has no singular point. Moreover, being integrable it is bounded (see theorem 13). We say that this proper integral is convergent because the Cauchy criterion works in this case for the point

b. Indeed, let $\varepsilon > 0$ be a small number and let $M = \sup_{x \in [a, b]} |f(x)|$. Let $\delta > 0$ be small enough such that $b - \delta > a$ and $\delta < \frac{\varepsilon}{M}$. Let $x', x'' \in [b - \delta, b]$ for this choice of δ . Then

$$\left| \int_{x'}^{x''} f(x) dx \right| \leq M |x' - x''| < M \cdot \frac{\varepsilon}{M} = \varepsilon.$$

Thus Cauchy criterion works in the case of a proper integral. This is why we say that a proper integral can be viewed as a convergent improper integral of the second type.

4. Problems and exercises

1. Test the convergence of the following improper integrals:

- a) $\int_1^\infty \frac{dx}{2x + \sqrt[3]{x^2 + 1}}$; b) $\int_0^\infty \frac{x dx}{\sqrt{x^5 + 1}}$; c) $\int_0^1 \frac{dx}{\sqrt[3]{1 - x^4}}$; d) $\int_1^2 \frac{dx}{\ln x}$; e) $\int_{\frac{\pi}{2}}^\infty \frac{\sin x}{x^2} dx$;
 f) $\int_0^\infty \frac{x \sqrt{x^3 + 2}}{x^7 + 1} dx$; g) $\int_1^3 \frac{dx}{\sqrt[3]{x - 1}}$; h) $\int_{-1}^2 \frac{(x^2 + 1) dx}{(x + 1) \sqrt[3]{x - 1}}$; i) $\int_0^\infty \cos(x^2) dx$;
 j) $\int_0^\infty x^2 \cos 2x dx$; k) $\int_0^\infty \frac{\arctan x}{x} dx$; l) $\int_2^4 \frac{dx}{(x - 2)^5}$; m) $\int_1^\infty \frac{(x^2 + 1) dx}{x^4 \sqrt[3]{x - 1}}$; n) $\int_0^1 \frac{dx}{x \ln x}$;
 o) $\int_t^\infty \frac{dx}{\sqrt{x(x - a)(x - b)}}$, where $t > a > b > 0$; p) $\int_0^\infty \left(e^{-\frac{a^2}{x^2}} - e^{-\frac{b^2}{x^2}} \right) dx$.

2. Compute (in the convergence case!) the following improper integrals:

- a) $\int_0^\infty e^{-2x} \sin 3x dx$; b) $\int_0^\infty e^{-ax} \cos b x dx$, $a > 0$; c) $\int_0^\infty \frac{dx}{(x^2 + a^2)(x^2 + 4)}$;
 d) $\int_0^\infty \frac{\arctan x}{(1 + x^2)^{3/2}} dx$; e) $\int_{-\infty}^\infty \frac{dx}{1 + x^2}$; f) $\int_0^\infty \sin 2x dx$ g) $\int_0^\infty x e^{-x^2} dx$;
 h) $\int_0^\infty x^3 e^{-kx^4} dx$, $k > 0$.

3. Can you use a computer to approximately compute the improper integrals?:

- a) $\int_1^\infty \frac{dx}{2x + \sqrt[3]{x^2 + 4x + 5}}$; b) $\int_{-1}^\infty \frac{dx}{x^2 + \sqrt[3]{x^4 + 1}}$;
 c) $\int_0^1 x^{-\frac{1}{2}} (1 - x)^{-\frac{2}{3}} dx$; d) $\int_0^\infty x^{-\frac{1}{2}} e^{-x} dx$;
 e) $\int_0^\infty e^{-x^8} dx$; f) $\int_0^\infty e^{-4x^4} dx$; g) $\int_0^\infty \frac{\tan^{-1} x}{(4 + x^2)} dx$; h) $\int_0^\infty \cos x^2 dx$.

CHAPTER 4

Integrals with parameters

1. Proper integrals with parameters

EXAMPLE 54. (*a motivation*) A linear wire is a segment $[a, b]$ with a density function f defined on it. We assume that physical properties of the wire are changing during time. Thus $a = a(t)$, $b = b(t)$ are functions of time and the density function $f = f(x, t)$, where $x \in (a(t), b(t))$ is a function of time and of the point x . When time t varies in an interval J , we suppose that the extremities $a(t)$, $b(t)$ of the wire belong to a fixed interval K . At any fixed moment $t \in J$, the mass of the linear wire is:

$$(1.1) \quad M(t) = \int_{a(t)}^{b(t)} f(x, t) dx,$$

if the function $g_t(x) = f(x, t)$ is integrable on $[a(t), b(t)]$ for any $t \in J$. We just obtained a new function $M : J \rightarrow \mathbb{R}$ which describes the variation of the mass of the wire as a function of time t . Since the integral on the right in formula (1.1) depends on a "parameter" t , we say that this last integral is "an integral with a parameter t ".

Here is a more general definition for the notion of an integral with n parameters t_1, t_2, \dots, t_n . Let J be a subset of \mathbb{R}^n and let $\mathbf{t} = (t_1, t_2, \dots, t_n)$ be an arbitrary element of J . Let $a, b : J \rightarrow K \subset \mathbb{R} \cup \{\pm\infty\}$ be two functions of n variables defined on J with values into a fixed interval K of $\mathbb{R} \cup \{\pm\infty\}$ such that $a(\mathbf{t}) \leq b(\mathbf{t})$ for any \mathbf{t} in J . Let $f : K \times J \rightarrow \mathbb{R}$ be a (scalar) function of $n + 1$ variables $(x, t_1, t_2, \dots, t_n) = (x, \mathbf{t})$ which is integrable with respect to (w.r.t.) x on K for any fixed \mathbf{t} in J . This means that for any fixed \mathbf{t} in J , the integral $I(\mathbf{t}) = \int_{a(\mathbf{t})}^{b(\mathbf{t})} f(x, \mathbf{t}) dx$ exists for any fixed vector \mathbf{t} in J .

DEFINITION 12. The function $I : J \rightarrow \mathbb{R}$ defined by the formula

$$(1.2) \quad I(\mathbf{t}) = \int_{a(\mathbf{t})}^{b(\mathbf{t})} f(x, \mathbf{t}) dx$$

is said to be an integral with n parameters t_1, t_2, \dots, t_n . If for any $\mathbf{t} \in J$ this last integral $\int_{a(\mathbf{t})}^{b(\mathbf{t})} f(x, \mathbf{t}) dx$ is a proper integral we say that our integral is a proper integral with parameters t_1, t_2, \dots, t_n .

Let us now consider some examples of integrals with parameters. The integral $I(\lambda) = \int_0^1 \sin \lambda x dx$ with a parameter λ is defined for any $\lambda \in \mathbb{R}$. Thus $J = \mathbb{R}$ in this case. Functions $a(\lambda)$, $b(\lambda)$ are constant in this case, $a(\lambda) = 0$, and $b(\lambda) = 1$ for any $\lambda \in \mathbb{R}$. Thus $K = [0, 1]$ and so our integral is a proper integral with a parameter λ . Since a primitive $F(x) = \int \sin \lambda x dx$ can be computed in this case: $F(x) = -\frac{\cos \lambda x}{\lambda}$, if $\lambda \neq 0$ and $F(x) = 0$ if $\lambda = 0$. Hence

$$I(\lambda) = -\frac{\cos \lambda}{\lambda} + \frac{1}{\lambda} = \frac{1 - \cos \lambda}{\lambda},$$

if $\lambda \neq 0$. If $\lambda = 0$, $I(0) = 0$. A natural question arises: Is the function $I(\lambda)$ continuous at 0? Since $\lim_{\lambda \rightarrow 0} I(\lambda) = \frac{0}{0} \stackrel{\text{L'Hôpital}}{=} \lim_{\lambda \rightarrow 0} \sin \lambda = 0$, the answer is yes, because $I(0) = 0$. This example is the easiest possible case which can appear. Usually, the primitive with respect to x cannot be computed (expressed as an elementary function!) in $I(\mathbf{t}) = \int_{a(\mathbf{t})}^{b(\mathbf{t})} f(x, \mathbf{t}) dx$, so we need to use other "indirect" computation of this integral. For instance, $I(c) = \int_c^\infty e^{-cx^2} dx$, for $c > 0$ is an improper integral with a parameter c . Here $J = (0, \infty)$, $K = (0, \infty)$, $a(c) = c$, the identity function and $b(c) = \infty$. For any fixed $c > 0$ our integral is convergent (apply the test p for $p = 2$). Since any primitive of e^{-x^2} is not an elementary function (this is a very deep result in Math and cannot be proved in this course!), any primitive of e^{-cx^2} , $c > 0$, is not also an elementary function (why?). Thus we cannot directly compute $I(c)$. In the next section we shall see how to compute such integrals with parameters (not exactly this last one! We shall only compute $I'(c) = e^{-c^3} \left(\frac{1}{2c} - 1 \right)$).

Let us consider in the following only proper integrals with one parameter, because we can ignore all the others parameters while we separately work with one of them. Thus, let us consider $I(t) = \int_{a(t)}^{b(t)} f(x, t) dx$, $t \in J \subset \mathbb{R}$, J an interval, $a, b : J \rightarrow K \subset \mathbb{R}$ and $f(x, t)$ is integrable w.r.t. the variable x on the interval K . The first natural question is if the function I is continuous on J if the functions $a(t)$, $b(t)$ and $f(x, t)$ are continuous on J and respectively on $K \times J$.

THEOREM 48. (continuity theorem) *With the above notation, if functions $a(t)$, $b(t)$ and $f(x, t)$ are continuous on J and respectively*

on $K \times J$, then the new function $I : J \rightarrow \mathbb{R}$, $I(t) = \int_{a(t)}^{b(t)} f(x, t) dx$ is also continuous on J .

PROOF. Let us fix a point t_0 in J and let us prove that the function I is continuous at this fixed point t_0 . For this let us take an arbitrary sequence $\{t_n\}$ in J such that $t_n \rightarrow t_0$. To prove the continuity of I at t_0 it is enough to prove that $I(t_n) \rightarrow I(t_0)$. For this last statement, let us evaluate the difference $I(t_n) - I(t_0)$:

$$(1.3) \quad I(t_n) - I(t_0) = \int_{a(t_n)}^{b(t_n)} f(x, t_n) dx - \int_{a(t_0)}^{b(t_0)} f(x, t_0) dx =$$

$$\int_{a(t_n)}^{a(t_0)} f(x, t_n) dx + \int_{a(t_0)}^{b(t_0)} f(x, t_n) dx + \int_{b(t_0)}^{b(t_n)} f(x, t_n) dx - \int_{a(t_0)}^{b(t_0)} f(x, t_0) dx.$$

To evaluate the integrals $\int_{a(t_n)}^{a(t_0)} f(x, t_n) dx$ and $\int_{b(t_0)}^{b(t_n)} f(x, t_n) dx$ we apply the mean formula (see theorem 22) and find:

$$(1.4) \quad \int_{a(t_n)}^{a(t_0)} f(x, t_n) dx = f(c_n, t_n) [a(t_0) - a(t_n)]$$

and

$$(1.5) \quad \int_{b(t_0)}^{b(t_n)} f(x, t_n) dx = f(d_n, t_n) [b(t_n) - b(t_0)],$$

where c_n is between $a(t_n)$ and $a(t_0)$ and d_n is between $b(t_n)$ and $b(t_0)$. Since functions $a(t)$ and $b(t)$ are continuous and $t_n \rightarrow t_0$, we see that the sequence $\{c_n\}$ converges to $a(t_0)$ and the sequence $\{d_n\}$ tends to $b(t_0)$. Since f is a continuous function as a function of two variables, we see that $f(c_n, t_n) \rightarrow f(a(t_0), t_0)$ and $f(d_n, t_n) \rightarrow f(b(t_0), t_0)$. But $a(t_0) - a(t_n) \rightarrow 0$ and $b(t_n) - b(t_0) \rightarrow 0$, so that

$$\int_{a(t_n)}^{a(t_0)} f(x, t_n) dx \rightarrow f(a(t_0), t_0) \cdot 0 = 0$$

and

$$\int_{b(t_0)}^{b(t_n)} f(x, t_n) dx \rightarrow f(b(t_0), t_0) \cdot 0 = 0.$$

Thus, in formula (1.3) it remains to prove that

$$(1.6) \quad \int_{a(t_0)}^{b(t_0)} f(x, t_n) dx - \int_{a(t_0)}^{b(t_0)} f(x, t_0) dx = \int_{a(t_0)}^{b(t_0)} [f(x, t_n) - f(x, t_0)] dx \rightarrow 0,$$

whenever $n \rightarrow \infty$. By taking a sufficiently rich division $\Delta : t_0 = a(t_0) < t_1 < \dots < t_k = b(t_0)$

of the interval $[a(t_0), b(t_0)]$ and by using the uniform continuity of f , one can easily prove that

$$\int_{a(t_0)}^{b(t_0)} [f(x, t_n) - f(x, t_0)] dx \rightarrow 0. \quad \square$$

Why this last theorem is important? For instance, let $I(t) = \int_0^{t^2+2} e^{-tx^2} dx$, $t \in \mathbb{R}$ and the problem is to compute $L = \lim_{t \rightarrow 0} I(t)$. Usually, we make $t = 0$ in the integral expression of $I(t)$. But, making this, we just intrinsically applied the above continuity theorem. Indeed, $L = \lim_{t \rightarrow 0} I(t) = I(\lim_{t \rightarrow 0} t) = I(0) = \int_0^2 dx = 2$. Of course, the continuity conditions on $a(t) = t^2 + 2$, $b(t) = 0$ and on $f(x, t) = e^{-tx^2}$ are obviously satisfied (in order to be able to apply the continuity theorem).

In many practical problems we need to see if the function

$I(t) = \int_{a(t)}^{b(t)} f(x, t) dx$ is differentiable or not and, if it is so, how do we compute its derivative? The great German mathematician G. W. von Leibniz (1646-1716) discovered a very nice and useful formula for the computation of $I'(t)$, the differential of function $I(t)$.

We start with the case when both functions $a, b : J \rightarrow \mathbb{R}$ are constant, say $a(t) = a_0$ and $b(t) = b_0$ for any t in J . We also assume that $f(x, t)$ is differentiable with respect to t for any fixed x in K and that its differential $\frac{\partial f}{\partial t}(x, t)$ is a continuous function w. r. t. t .

THEOREM 49. *We assume that the functions a, b and f verify these last properties. Then the integral $I(t) = \int_{a_0}^{b_0} f(x, t) dx$ is differentiable and*

$$(1.7) \quad I'(t) = \int_{a_0}^{b_0} \frac{\partial f}{\partial t}(x, t) dx$$

for any $t \in J$.

PROOF. Let us fix t_0 in J and let us evaluate the ratio

$$\frac{I(t) - I(t_0)}{t - t_0} = \frac{\int_{a_0}^{b_0} [f(x, t) - f(x, t_0)] dx}{t - t_0}.$$

For any fixed x in $[a_0, b_0]$ we define $g_x : [t, t_0]^\pm \rightarrow \mathbb{R}$ by $g_x(\zeta) = f(x, \zeta)$. Here $[t, t_0]^\pm = [t, t_0]$ if $t \leq t_0$ and $[t, t_0]^\pm = [t_0, t]$ if $t_0 \leq t$. Let us write Lagrange's formula for the function g_x on the interval $[t, t_0]^\pm$ (i.e. we must consider 2 cases, $t \leq t_0$ and $t \geq t_0$ respectively). In both cases one has:

$$g_x(t) - g_x(t_0) = g'_x(c_{x,t})(t - t_0),$$

where $c_{x,t} \in [t, t_0]^\pm$. Thus

$$\frac{I(t) - I(t_0)}{t - t_0} = \frac{\int_{a_0}^{b_0} \frac{\partial f}{\partial t}(x, c_{x,t})(t - t_0) dx}{(t - t_0)} = \int_{a_0}^{b_0} \frac{\partial f}{\partial t}(x, c_{x,t}) dx.$$

Since $\frac{\partial f}{\partial t}(x, c_{x,t})$ is a new continuous function $h(x, t)$ of two variables, we can apply the continuity theorem 48 to the proper integral

$$\int_{a_0}^{b_0} \frac{\partial f}{\partial t}(x, c_{x,t}) dx = \int_{a_0}^{b_0} h(x, t) dx$$

with parameter t and obtain

$$\lim_{t \rightarrow t_0} \frac{I(t) - I(t_0)}{t - t_0} = \int_{a_0}^{b_0} \lim_{t \rightarrow t_0} h(x, t) dx = \int_{a_0}^{b_0} \frac{\partial f}{\partial t}(x, t_0) dx,$$

because $c_{x,t} \rightarrow t_0$, whenever $t \rightarrow t_0$. Hence $I(t)$ is differentiable at t_0 and formula (1.7) is true. \square

Let us use this last theorem to compute the derivative of the function $I(t) = \int_{\pi}^{\frac{\pi}{2}} \frac{\cos tx}{x} dx$. It is known in a very high level of Mathematics that in general no primitive of function $g(x) = \frac{\cos x}{x}$ can be an elementary function (in literature the primitive $\int \frac{\cos x}{x} dx$ is called the *integral cosine*). Thus, it cannot be computed with the usual Newton-Leibniz formula. Sometimes we are not interested in the mathematical expression of $I(t)$ but, for instance, we are interested to compute "its velocity" $I'(t)$. To do this, let us use formula 1.7

$$I'(t) = - \int_{\pi}^{\frac{\pi}{2}} \sin tx dx = \frac{1}{t} \left[\cos \pi t - \cos \frac{\pi}{2} t \right].$$

We now consider the case when one of functions $a(t)$ or $b(t)$ is constant and the other is not constant but it is differentiable on J . Take for instance $a(t)$ to be nonconstant and $b(t)$ to be a fixed constant b_0 . We also assume that $f(x, t)$ is continuous with respect to both of its variables and that $\frac{\partial f}{\partial t}(x, t)$ is continuous w.r t. t .

THEOREM 50. *We assume that all of these last conditions are satisfied for the integral of a parameter t , $I(t) = \int_{a(t)}^{b(t)} f(x, t) dx$, i.e. $I(t) = \int_{a(t)}^{b_0} f(x, t) dx$ in our case. Then function $I(t)$ is differentiable and*

$$(1.8) \quad I'(t) = \int_{a(t)}^{b_0} \frac{\partial f}{\partial t}(x, t) dx - a'(t) f(a(t), t)$$

for any $t \in J$.

PROOF. Let us fix a point $t_0 \in J$ and let us evaluate the ratio

$$\begin{aligned} \frac{I(t) - I(t_0)}{t - t_0} &= \frac{\int_{a(t)}^{b_0} f(x, t) dx - \int_{a(t_0)}^{b_0} f(x, t_0) dx}{t - t_0} = \frac{\int_{a(t)}^{a(t_0)} [f(x, t)] dx}{t - t_0} + \\ &+ \frac{\int_{a(t_0)}^{b_0} [f(x, t) - f(x, t_0)] dx}{t - t_0}. \end{aligned}$$

The limit of

$$\frac{\int_{a(t_0)}^{b_0} [f(x, t) - f(x, t_0)] dx}{t - t_0}$$

when $t \rightarrow t_0$ is exactly

$$\int_{a(t_0)}^{b_0} \frac{\partial f}{\partial t}(x, t_0) dx$$

(see the proof of theorem 49). Thus, it remains to prove that the limit of $\frac{\int_{a(t)}^{a(t_0)} [f(x, t)] dx}{t - t_0}$ when $t \rightarrow t_0$ is equal to $-a'(t_0)f(a(t_0), t_0)$. To do this, let us apply mean formula of theorem (22) to the integral $\int_{a(t)}^{a(t_0)} [f(x, t)] dx$:

$$\int_{a(t)}^{a(t_0)} [f(x, t)] dx = f(d_t, t) [a(t_0) - a(t)],$$

where $d_t \in [a(t), a(t_0)]^\pm$. Since $a(t)$ is also continuous, $a(t) \rightarrow a(t_0)$ and so $d_t \rightarrow a(t_0)$, whenever $t \rightarrow t_0$. Thus,

$$\lim_{t \rightarrow t_0} \frac{\int_{a(t)}^{a(t_0)} [f(x, t)] dx}{t - t_0} = f(a(t_0), t_0) \cdot \lim_{t \rightarrow t_0} \frac{a(t_0) - a(t)}{t - t_0} = -a'(t_0)f(a(t_0), t_0).$$

Finally we put together both limits computed above and obtain:

$$\begin{aligned} \lim_{t \rightarrow t_0} \frac{I(t) - I(t_0)}{t - t_0} &= \lim_{t \rightarrow t_0} \frac{\int_{a(t)}^{a(t_0)} [f(x, t)] dx}{t - t_0} + \lim_{t \rightarrow t_0} \frac{\int_{a(t_0)}^{b_0} [f(x, t) - f(x, t_0)] dx}{t - t_0} = \\ &= -a'(t_0)f(a(t_0), t_0) + \int_{a(t_0)}^{b_0} \frac{\partial f}{\partial t}(x, t_0) dx, \end{aligned}$$

i.e. we just obtained formula (1.8) for $t = t_0$. □

Let us apply this last formula to compute the following limit:

$$\lim_{t \rightarrow \frac{\pi}{2}} \frac{\int_{\sin t}^1 e^{x^2} dx}{\int_{\cos t}^0 e^{x^2} dx}.$$

Let us see that we are in the nondeterminate case $\frac{0}{0}$ and so we can apply l'Hôpital rule:

$$\lim_{t \rightarrow \frac{\pi}{2}} \frac{\int_{\sin t}^1 e^{x^2} dx}{\int_{\cos t}^0 e^{x^2} dx} = \lim_{t \rightarrow \frac{\pi}{2}} \frac{\left[\int_{\sin t}^1 e^{x^2} dx \right]'}{\left[\int_{\cos t}^0 e^{x^2} dx \right]'} = \lim_{t \rightarrow \frac{\pi}{2}} \frac{(-\cos t)e^{\sin^2 t}}{(\sin t)e^{\cos^2 t}} = 0.$$

Here we applied formula (1.8) to compute the both derivatives

$$\left[\int_{\sin t}^1 e^{x^2} dx \right]' \text{ and } \left[\int_{\cos t}^0 e^{x^2} dx \right]'$$

We are now ready to give the general formula of Leibniz for a proper integral with a parameter t .

THEOREM 51. (Leibniz formula) *Let $I(t) = \int_{a(t)}^{b(t)} f(x, t) dx$ be an integral with a parameter $t \in J$, where both functions $a(t)$ and $b(t)$ are differentiable on J and $f(x, t)$ is continuous and of class C^1 with respect to the variable t . Then the function $I(t)$ is differentiable and the following Leibniz formula is true:*

$$(1.9) \quad I'(t) = \int_{a(t)}^{b(t)} \frac{\partial f}{\partial t}(x, t) dx + b'(t)f(b(t), t) - a'(t)f(a(t), t).$$

PROOF. First of all let us see that this formula generalizes both formulas (1.7) and (1.8). We shall see that these last formulas are enough in order to deduce the general Leibniz formula (1.9). Let us fix a $t_0 \in J$ and let us write

$$I(t) = \int_{a(t)}^{b(t)} f(x, t) dx = \int_{a(t)}^{a(t_0)} f(x, t) dx + \int_{a(t_0)}^{b(t_0)} f(x, t) dx + \int_{b(t_0)}^{b(t)} f(x, t) dx.$$

It will be enough to prove that each integral-function of t on the right of this last formula is differential and to separately find a formula for its derivative.

Indeed, from formula (1.8) we see that

$$(1.10) \quad \left[\int_{a(t)}^{a(t_0)} f(x, t) dx \right]' = \int_{a(t)}^{a(t_0)} \frac{\partial f}{\partial t}(x, t) dx - a'(t)f(a(t), t).$$

From formula (1.7) we find

$$\left[\int_{a(t_0)}^{b(t_0)} f(x, t) dx \right]' = \int_{a(t_0)}^{b(t_0)} \frac{\partial f}{\partial t}(x, t) dx.$$

At last, from formula (1.8) one has:

$$(1.11) \quad \left[\int_{b(t_0)}^{b(t)} f(x, t) dx \right]' = - \left[\int_{b(t)}^{b(t_0)} f(x, t) dx \right]' =$$

$$= - \int_{b(t)}^{b(t_0)} \frac{\partial f}{\partial t}(x, t) dx + b'(t)f(b(t), t).$$

If we make the sum of both sides for these above three formulas we get

$$\begin{aligned} I'(t) &= \int_{a(t)}^{a(t_0)} \frac{\partial f}{\partial t}(x, t) dx - a'(t)f(a(t), t) + \int_{a(t_0)}^{b(t_0)} \frac{\partial f}{\partial t}(x, t) dx - \\ &\quad - \int_{b(t)}^{b(t_0)} \frac{\partial f}{\partial t}(x, t) dx + b'(t)f(b(t), t). \end{aligned}$$

But

$$\begin{aligned} &\int_{a(t)}^{a(t_0)} \frac{\partial f}{\partial t}(x, t) dx + \int_{a(t_0)}^{b(t_0)} \frac{\partial f}{\partial t}(x, t) dx - \int_{b(t)}^{b(t_0)} \frac{\partial f}{\partial t}(x, t) dx = \\ &= \int_{a(t)}^{a(t_0)} \frac{\partial f}{\partial t}(x, t) dx + \int_{a(t_0)}^{b(t_0)} \frac{\partial f}{\partial t}(x, t) dx + \int_{b(t_0)}^{b(t)} \frac{\partial f}{\partial t}(x, t) dx = \\ &= \int_{a(t)}^{b(t)} \frac{\partial f}{\partial t}(x, t) dx. \end{aligned}$$

Hence

$$I'(t) = \int_{a(t)}^{b(t)} \frac{\partial f}{\partial t}(x, t) dx + b'(t)f(b(t), t) - a'(t)f(a(t), t).$$

□

Let us compute $I'(t)$ for $I(t) = \int_t^{t^2} \frac{\sin tx}{x} dx$, for $t \in \mathbb{R}$. We simply use Leibniz formula and find

$$\begin{aligned} I'(t) &= \int_t^{t^2} \cos txdx + 2t \frac{\sin t^3}{t} - \frac{\sin t^2}{t} = \frac{\sin tx}{t} \Big|_t^{t^2} + 2 \sin t^3 - \frac{\sin t^2}{t} = \\ &= \frac{\sin t^3}{t} - 2 \frac{\sin t^2}{t} + 2 \sin t^3. \end{aligned}$$

The following result was discovered by the Italian mathematician Guido Fubini (1879–1943) in a more general form. This is why it is called Fubini's theorem. We state this result here in a particular form. This form is enough for us in the following applications.

THEOREM 52. (*Fubini's theorem*) *Let $K = [a, b]$ and $J = [c, d]$ be two real closed intervals and let $f : K \times J \rightarrow \mathbb{R}$ be a continuous function $f(x, t)$ of two variables. Then*

$$(1.12) \quad \int_a^b \left(\int_c^d f(x, t) dt \right) dx = \int_c^d \left(\int_a^b f(x, t) dx \right) dt.$$

PROOF. 1) First of all let us explain what formula (1.12) says. Let us denote $J(x) = \int_c^d f(x, t)dt$, a proper integral with a parameter x and let denote by $L(t) = \int_a^b f(x, t)dx$, a proper integral with a parameter t . Formula (1.12) says that $\int_a^b J(x)dx = \int_c^d L(t)dt$, i.e. we may change the order of integration.

For proving Fubini's formula we put $F(u) = \int_a^u \left(\int_c^d f(x, t)dt \right) dx$ and $G(u) = \int_c^d \left(\int_a^u f(x, t)dx \right) dt$ for any $u \in [a, b]$. If we succeed to prove that $F(u) = G(u)$ for any $u \in [a, b]$, by making $u = b$, we would obtain formula (1.12). Let us carefully use Leibniz formula (1.9) to compute $F'(u)$ and $G'(u)$.

$$F'(u) = \int_c^d f(u, t)dt, \quad G'(u) = \int_c^d f(u, t)dt.$$

Thus, $F'(u) = G'(u)$ for any $u \in [a, b]$. Hence $F(u) = G(u) + C$, where C is a constant w.r.t. u . Let us put $u = a$ and find $F(a) = G(a) + C$ and, since $F(a) = G(a) = 0$, we find that $C = 0$, i.e. $F(u) = G(u)$ and the first proof is completed. Here is another proof. We present it at an intuitive level. But, by using the uniform continuity of f , one can improve it up to a correct mathematical proof.

2) Let us consider two arbitrary divisions

$$\Delta_x : a = x_0 < x_1 < \dots < x_n = b$$

and

$$\Delta_t : c = t_0 < t_1 < \dots < t_m = d$$

of the intervals $[a, b]$ and $[c, d]$ respectively. Let us denote by $M_1 = \int_a^b J(x)dx$ and by $M_2 = \int_c^d L(t)dt$. We can approximate very well the number M_1 by Riemann sums of the form

$$(1.13) \quad \sum_{i=1}^n J(\xi_i)(x_i - x_{i-1}),$$

where $\xi_i \in [x_{i-1}, x_i]$ for any $i = 1, 2, \dots, n$. Here divisions Δ_x and $\xi_i \in [x_{i-1}, x_i]$ are arbitrary and if the norm $\|\Delta_x\| \rightarrow 0$, then the above Riemann sums become closer and closer to M_1 . Let us fix now such a division Δ_x and a set of marking points $\{\xi_i\}$ such that the corresponding Riemann sum to be as close as we want to M_1 . Each number $J(\xi_i) = \int_c^d f(\xi_i, t)dt$ can be well approximate by Riemann sums of the form

$$\sum_{j=1}^m f(\xi_i, \eta_j)(t_j - t_{j-1}).$$

Thus M_1 can be well approximate with sums of the type

$$(1.14) \quad \sum_{i=1}^n \sum_{j=1}^m f(\xi_i, \eta_j)(t_j - t_{j-1})(x_i - x_{i-1}).$$

In the same manner we can prove that $M_2 = \int_c^d L(t)dx$ can be well approximate with double sums of the form

$$(1.15) \quad \sum_{j=1}^m \sum_{i=1}^n f(\xi_i, \eta_j)(x_i - x_{i-1})(t_j - t_{j-1}).$$

Since the sum and the product are commutative we see that the above double sums are equal. Hence the numbers M_1 and M_2 can be well approximate by the one and the same set of numbers of the form

$$\sum_{i=1}^n \sum_{j=1}^m f(\xi_i, \eta_j)(t_j - t_{j-1})(x_i - x_{i-1}).$$

Let us denote by A this set of numbers. Assume that $M_1 \neq M_2$. Then, taking ε such that $0 < \varepsilon < \frac{|M_1 - M_2|}{2}$, one sees that

$$(M_1 - \varepsilon, M_1 + \varepsilon) \cap (M_2 - \varepsilon, M_2 + \varepsilon) = \emptyset.$$

But there exist an infinite number of elements in A which are contained in this intersection! Thus, our assumption that $M_1 \neq M_2$ is not true. This means that $M_1 = M_2$, i.e. Fubini's formula. \square

To change the order of integration could be a real necessity in some cases. For instance, the computation of $\int_1^2 \left(\int_1^2 \frac{\ln tx}{x} dx \right) dt$ in this order, i.e. first of all we compute $J(t) = \int_1^2 \frac{\ln tx}{x} dx$ and then we compute $\int_1^2 J(t)dt$, is more complicated than to change the order of integration (Fubini's formula), namely to compute $\int_1^2 \left(\int_1^2 \frac{\ln tx}{x} dt \right) dx$ (convince yourself!).

REMARK 18. If $f : D \rightarrow \mathbb{R}$, where D is the rectangle $[a, b] \times [c, d]$, then a double sum of the form

$$\sum_{j=1}^m \sum_{i=1}^n f(\xi_i, \eta_j)(x_i - x_{i-1})(t_j - t_{j-1})$$

is called a Riemann double sum for the function f . If all this double sums becomes closer and closer to a number I , we say that I is the

double integral of f on the rectangle D . Write $I = \iint_D f(x, t) dx dt$.

Fubini's formula says that if f is continuous, then this last number always exist and it can be computed as:

$$\iint_D f(x, t) dx dt = \int_a^b \left(\int_c^d f(x, t) dt \right) dx = \int_c^d \left(\int_a^b f(x, t) dx \right) dt.$$

Such formulas are called iterative formulas for the computation of a double integral on a rectangle $D = [a, b] \times [c, d]$ (see more on this topic in chapter 6).

2. Improper integrals with parameters

A function f with n parameters $\mathbf{t} = (t_1, t_2, \dots, t_n) \in J \subset \mathbb{R}^n$, where J is a domain in \mathbb{R}^n , is simply a function $f(x, \mathbf{t})$ of $n + 1$ variables, $f : K \times J \rightarrow \mathbb{R}$, where K is a real interval, finite or not. Let b be a limit point of K , i.e. $b \in \mathbb{R} \cup \{\pm\infty\}$ and it is a limit of at least an infinite sequence of elements of K . We assume that for any fixed \mathbf{t} in J the following limit $g(\mathbf{t}) = \lim_{x \rightarrow b} f(x, \mathbf{t})$ exists. The obtained function $g : J \rightarrow \mathbb{R}$ is called the *simple (pointwise) limit of f at b , along the set of parameters J* . The limit function g is said to be *uniform w.r.t. (along) the set of parameters J* if for any small $\varepsilon > 0$, there is a neighborhood V_b of b in K (it is of the form $(b - \delta, b + \delta) \cap K$, (M, ∞) if $b = \infty$, or $(-\infty, M)$ if $b = -\infty$) such that

$$|g(\mathbf{t}) - f(x, \mathbf{t})| < \varepsilon$$

for any $x \in V_b$ and for any $\mathbf{t} \in J$.

For instance $f(x, t) = e^{xt}$, $x \in (0, 1]$, $t \in J = (-3, 2]$ has the uniform function limit $g(t) = 1$ at $b = 0$. Indeed, if $\varepsilon > 0$, $|e^{xt} - 1| < \varepsilon$ if

$$x < \delta = \min \left\{ \frac{1}{2} \ln(1 + \varepsilon), -\frac{1}{3} \ln(1 - \varepsilon) \right\}$$

for any $t \in (-3, 2]$. If instead of $J = (-3, 2]$ we take $J = \mathbb{R}$, we easily see that $g(t) = 1$ is a simple limit of $f(x, t) = e^{xt}$ at $b = 0$, but it is not uniform.

It is obvious that if a function $f(x, \mathbf{t})$ of a variable x and with a set of n parameters $\mathbf{t} = (t_1, t_2, \dots, t_n) \in J \subset \mathbb{R}^n$, J a domain, $x \in K$, where K is a real interval in \mathbb{R} , has a uniform limit $g(\mathbf{t})$ at b , w.r.t. J , then it is also a simple limit at b .

Following the proof of theorem 31 it is not difficult to prove the following analogous result.

THEOREM 53. (*Cauchy criterion of the uniform limit*) Let K be an interval of \mathbb{R} and let $b \in \overline{\mathbb{R}}$ be a limit point of K . Let $f : K \times J \rightarrow \mathbb{R}$

be a function with n parameters $\mathbf{t} = (t_1, t_2, \dots, t_n) \in J \subset \mathbb{R}^n$, where J is a domain in \mathbb{R}^n . a) If b is finite, i.e. if $b \in \mathbb{R}$, then f has an uniform limit $g(\mathbf{t})$ at b along the set of parameters J , if and only if for any small real number $\varepsilon > 0$ there is a real number $\delta > 0$ such that if two numbers x' and x'' are in $K \cap (b - \delta, b + \delta)$, then the distance between $f(x', \mathbf{t})$ and $f(x'', \mathbf{t})$ is less than ε , i.e. $|f(x', \mathbf{t}) - f(x'', \mathbf{t})| < \varepsilon$ for any $\mathbf{t} \in J$. b) If b is not finite, say $b = \infty$, then f has a uniform limit at b along the set of parameters J if and only if for any small real number $\varepsilon > 0$ there is a large real number $M > 0$ such that if two numbers x' and x'' are greater than M , then the distance between $f(x', \mathbf{t})$ and $f(x'', \mathbf{t})$ is less than ε , i.e. $|f(x', \mathbf{t}) - f(x'', \mathbf{t})| < \varepsilon$ for any $\mathbf{t} \in J$. For $b = -\infty$ we must replace this last M with a negative, near to $-\infty$, M , i.e. in this case $M < 0$ and $-M$ is very large. Moreover, the expression " x' and x'' are greater than M " must be substituted with " x' and x'' are less than M ".

EXAMPLE 55. Here is a more complicated example of how we apply this last criterion. Let us define $f(x, t) = \int_0^x \frac{\arctan tu}{u(u+1)} du$, $x \in K = [0, \infty)$, $t \in J = \mathbb{R}$. Let us study the limit $\lim_{x \rightarrow \infty} f(x, t) = g(t)$. Here $b = \infty$ is a limit point of \mathbb{R} and it is the unique singular point of our integral because $\lim_{u \rightarrow 0} \frac{\arctan tu}{u(u+1)} = t$, i.e. 0 is a false (illusory) singular point. For any fixed t in \mathbb{R} this limit is nothing else than the improper integral $\int_0^\infty \frac{\arctan tu}{u(u+1)} du$. This integral is convergent because

$$\int_0^\infty \frac{\arctan tu}{u(u+1)} du = \int_0^1 \frac{\arctan tu}{u(u+1)} du + \int_1^\infty \frac{\arctan tu}{u(u+1)} du,$$

$$\left| \frac{\arctan tu}{u(u+1)} \right| \leq \frac{\pi}{2} \frac{1}{u(u+1)}$$

and

$$\int_1^\infty \frac{1}{u(u+1)} du$$

is convergent (apply test p with $p = 2$). Thus our limit exists for any fixed t in \mathbb{R} . Since $g(t) = \int_0^\infty \frac{\arctan tu}{u(u+1)} du$ we cannot (for the moment) compute $g(t)$ and then to use the definition of the uniform limit to decide if this limit is or is not uniform w.r.t. t . Let us use Cauchy criterion 53 to prove that our limit is a uniform one. For this let us evaluate $\int_{x'}^{x''} \frac{\arctan tu}{u(u+1)} du$ for x', x'' very close to ∞ (large enough). Simply, it is sufficient to prove that $\left| \int_{x'}^{x''} \frac{\arctan tu}{u(u+1)} du \right|$ becomes smaller and smaller when x', x'' become larger and larger independent (uniformly) with respect to the parameter t . Here we use a simple and efficient idea

of K . Weierstrass. Namely, let us put instead of $\left| \frac{\arctan tu}{u(u+1)} \right|$ a greater function $h(u)$ which does not contain the parameter t at all and then try to prove the Cauchy criterion for the improper integral $\int_1^\infty h(u)du$. Indeed, since $\left| \frac{\arctan tu}{u(u+1)} \right| \leq \frac{\pi}{2} \frac{1}{u(u+1)}$, $h(u) = \frac{\pi}{2} \frac{1}{u(u+1)}$ and, since the improper integral (without a parameter) $\frac{\pi}{2} \int_1^\infty \frac{1}{u(u+1)} du$ is convergent (apply test

p with $p = 2$), so the Cauchy criterion condition works, one has that for any small $\varepsilon > 0$ there exists $M > 0$ such that if $x', x'' > M$ we get $\frac{\pi}{2} \left| \int_{x'}^{x''} \frac{1}{u(u+1)} du \right| < \varepsilon$. Thus, since

$$\left| \int_{x'}^{x''} \frac{\arctan tu}{u(u+1)} du \right| \leq \int_{x'}^{x''} \left| \frac{\arctan tu}{u(u+1)} \right| du \leq \frac{\pi}{2} \left| \int_{x'}^{x''} \frac{1}{u(u+1)} du \right| < \varepsilon$$

we obtain that $\left| \int_{x'}^{x''} \frac{\arctan tu}{u(u+1)} du \right| < \varepsilon$ for any $x', x'' > M$. Hence

$$g(t) = \int_0^\infty \frac{\arctan tu}{u(u+1)} du = \int_0^1 \frac{\arctan tu}{u(u+1)} du + \int_1^\infty \frac{\arctan tu}{u(u+1)} du$$

is the uniform limit of $f(x, t)$ relative to the parameter t .

THEOREM 54. (continuity theorem) Let $f(x, \mathbf{t})$, $f : K \times J \rightarrow \mathbb{R}$, where K is a real interval and J is the domain of parameters $\mathbf{t} = (t_1, t_2, \dots, t_n)$, $J \subset \mathbb{R}^n$. Assume that f is continuous with respect to the variable vector \mathbf{t} and that f has a uniform limit $g(\mathbf{t})$ at a limit point b of K . Then $g(\mathbf{t}) = \lim_{x \rightarrow b} f(x, \mathbf{t})$ is a continuous function of its vector variable \mathbf{t} . Thus, for any fixed $\mathbf{t}_0 \in J$,

$$(2.1) \quad \lim_{\mathbf{t} \rightarrow \mathbf{t}_0} \left[\lim_{x \rightarrow b} f(x, \mathbf{t}) \right] = \lim_{x \rightarrow b} f(x, \mathbf{t}_0).$$

PROOF. Let us choose a fixed point \mathbf{t}_0 in J and let us prove the continuity of g at this point \mathbf{t}_0 . For this, let us evaluate the difference

$$(2.2) \quad |g(\mathbf{t}) - g(\mathbf{t}_0)| \leq |g(\mathbf{t}) - f(x, \mathbf{t})| + |f(x, \mathbf{t}) - f(x, \mathbf{t}_0)| + |f(x, \mathbf{t}_0) - g(\mathbf{t}_0)|.$$

Since f has a uniform limit $g(\mathbf{t})$ at b , for a fixed small $\varepsilon > 0$, there is a neighborhood V_b of b in K (see the above definition of this notion!) such that

$$(2.3) \quad |g(\mathbf{t}) - f(x, \mathbf{t})| < \frac{\varepsilon}{3}, \text{ and } |f(x, \mathbf{t}_0) - g(\mathbf{t}_0)| < \frac{\varepsilon}{3}$$

for any $x \in V_b$ and for any $\mathbf{t} \in J$. Now let us fix such an $x_0 \in V_b$ and write again the inequality (2.2) for $x = x_0$:

$$(2.4) \quad |g(\mathbf{t}) - g(\mathbf{t}_0)| \leq |g(\mathbf{t}) - f(x_0, \mathbf{t})| + |f(x_0, \mathbf{t}) - f(x_0, \mathbf{t}_0)| + |f(x_0, \mathbf{t}_0) - g(\mathbf{t}_0)|.$$

Since function $\mathbf{t} \rightarrow f(x_0, \mathbf{t})$ is continuous at \mathbf{t}_0 , there is a small real number $\delta > 0$ such that if $\|\mathbf{t} - \mathbf{t}_0\| < \delta$, we get

$$(2.5) \quad |f(x_0, \mathbf{t}) - f(x_0, \mathbf{t}_0)| < \frac{\varepsilon}{3}.$$

Let us use the three inequalities (2.3) and (2.5) in the evaluation (2.4) to finally obtain:

$$|g(\mathbf{t}) - g(\mathbf{t}_0)| < \varepsilon$$

for any $\mathbf{t} \in J$ with $\|\mathbf{t} - \mathbf{t}_0\| < \delta$. But this exactly means the continuity of the function g at \mathbf{t}_0 . \square

EXAMPLE 56. Let us take the function $g(t) = \int_0^\infty \frac{\arctan tu}{u(u+1)} du$ (this is an improper integral with a parameter t , see the definition bellow) obtained as a uniform limit of $f(x, t) = \int_0^x \frac{\arctan tu}{u(u+1)} du$ when $x \rightarrow \infty$ and let us compute

$$\lim_{t \rightarrow 0^+} g(t) = \lim_{t \rightarrow 0^+} \int_0^\infty \frac{\arctan tu}{u(u+1)} du.$$

Since g is continuous (see the last theorem above), we can write $0 = g(0) = \lim_{t \rightarrow 0^+} g(t)$. Thus this limit is equal to 0. We simply put $x = 0$ under the integral sign. But, we must be very careful and not to do this before you did not prove that the limit is uniform!

With the supplementary condition that $f(x, \mathbf{t})$ has a finite limit at a limit point \mathbf{t}_0 of J , one can extend formula (2.1) for this more general case. For instance, if $a > 0$, then

$$\lim_{t \rightarrow \infty} \int_a^\infty \frac{\arctan tu}{u(u+1)} du = \int_a^\infty \frac{\arctan \infty}{u(u+1)} du = -\frac{\pi}{2} \ln \frac{a}{a+1}.$$

(What happens when $a \rightarrow 0$?).

The above theorem is sometimes used to decide if a limit is uniform or not. For instance, take $f(x, t) = t^x$, where $x \in \mathbb{R}$ and $t \in (0, 1]$. If $g(t) = \lim_{x \rightarrow \infty} f(x, t)$, it is easy to see that

$$g(t) = \begin{cases} 0, & \text{if } t < 1 \\ 1, & \text{if } t = 1 \end{cases}.$$

Since this function is not a continuous function, the above limit cannot be uniform with respect to the parameter t . This is also a counterexample to the fact that the hypothesis on limit to be a uniform one is necessary.

THEOREM 55. (*integration theorem*) Let K and J be real intervals, let b be a limit point of K and let $f : K \times J \rightarrow \mathbb{R}$, $f(x, t)$, be a function which has a uniform limit $g(t)$ at b , relative to the parameter t . Assume that $[a, c]$ is an interval contained in J and that f is continuous with respect to t on $[a, c]$. Then g is integrable on $[a, c]$ and

$$(2.6) \quad \int_a^c g(t)dt = \lim_{x \rightarrow b} \int_a^c f(x, t)dt,$$

or

$$(2.7) \quad \lim_{x \rightarrow b} \int_a^c f(x, t)dt = \int_a^c \lim_{x \rightarrow b} f(x, t)dt.$$

PROOF. Let $\varepsilon > 0$ be a small real number and let V_b be a neighborhood of b in K such that $|f(x, t) - g(t)| < \frac{\varepsilon}{c-a}$ for any $x \in V_b$ and for any $t \in J$. Since g is continuous on $[a, c]$ (see theorem 54) it is integrable. Let us evaluate the difference

$$\left| \int_a^c f(x, t)dt - \int_a^c g(t)dt \right| \leq \int_a^c |f(x, t) - g(t)| dt < \frac{\varepsilon}{c-a} \int_a^c dt = \varepsilon.$$

Thus $|\int_a^c f(x, t)dt - \int_a^c g(t)dt| < \varepsilon$ for any $x \in V_b$ and for any $t \in J$. But this is equivalent to saying that $\int_a^c g(t)dt = \lim_{x \rightarrow b} \int_a^c f(x, t)dt$. \square

This theorem is useful in practice. Let us compute for instance

$\lim_{x \rightarrow \infty} \int_0^1 e^{-xt^2} dt$. We know that the primitive of e^{-xt^2} as a function of t cannot be computed because it is not an elementary function. Function $f(x, t) = e^{-xt^2}$, $x \in [0, \infty)$, $t \in [0, 1]$ has an uniform limit, $g(t) = 0$, when $x \rightarrow \infty$. Let us apply now the last theorem and find

$$\lim_{x \rightarrow \infty} \int_0^1 e^{-xt^2} dt = \int_0^1 \lim_{x \rightarrow \infty} e^{-xt^2} dt = 0.$$

The hypothesis on the limit to be uniform is necessary. For instance, let $f(x, t) = xte^{-xt^2}$, $t \in [0, 1]$ and $x \in \mathbb{R}$. Let $g(t) = \lim_{x \rightarrow \infty} xte^{-xt^2} = 0$ for any fixed t in $[0, 1]$. If this limit were a uniform one, then formula (2.6) would be true. But,

$$\lim_{x \rightarrow \infty} \int_0^1 xte^{-xt^2} dt = \lim_{x \rightarrow \infty} -\frac{1}{2}e^{-xt^2} \Big|_0^1 = \frac{1}{2} \neq 0.$$

Thus the limit cannot be uniform. To directly prove that this limit is not uniform w.r.t. t is not an easy task. Hence the condition of uniformity in the last theorem is necessary.

THEOREM 56. (*differentiation theorem*) Let K and J be real intervals, let b be a limit point of K and let $f : K \times J \rightarrow \mathbb{R}$, $f(x, t)$, be a

function which has a simple limit $g(t)$ at b . Assume that f is of class C^1 on J and that the function $\frac{\partial f}{\partial t}(x, t)$ has a uniform limit $h(t)$ at b . Then $g(t)$ is differentiable on J and $g'(t) = h(t)$ for any t in J . We also can write this as

$$\left[\lim_{x \rightarrow b} f(x, t) \right]'_t = \lim_{x \rightarrow b} \frac{\partial f}{\partial t}(x, t).$$

PROOF. For any $u \in J$ we define

$$F(x, u) = \int_a^u \frac{\partial f}{\partial t}(x, t) dt = f(x, u) - f(x, a),$$

where a is a fixed point in J . Taking the uniform limits in both sides we get

$$\begin{aligned} \lim_{x \rightarrow b} \int_a^u \frac{\partial f}{\partial t}(x, t) dt &\stackrel{th.55}{=} \int_a^u \lim_{x \rightarrow b} \frac{\partial f}{\partial t}(x, t) dt = \int_a^u h(t) dt = \\ &= g(u) - g(a). \end{aligned}$$

From the last equality we get that $u \rightarrow g(u)$ is a differentiable function (it is expressed as an area function of Newton!) and $g'(u) = h(u)$ for any $u \in J$ (here we applied Leibniz formula for a proper integral). \square

We can now apply the above theory to our main topic, improper integrals with parameters. What is such an integral? Assume that in the symbolic expression of an integral $I(t) = \int_{a(t)}^{b(t)} f(x, t) dx$, with a parameter $t \in J$, one of the functions $a(t)$ or $b(t)$ is a constant $b \in \mathbb{R} \cup \{\pm\infty\}$ (we just fixed $b(t)$ to be a constant!) and for any $t \in J$, on the interval $[a(t), b]^\pm$, b is a singular point for the integral $\int_{a(t)}^b f(x, t) dx$ and it is unique with this property. Such an integral is called an *improper integral with a parameter t* . The same definition can be given for many parameters instead of one. For instance, $I(t) = \int_t^\infty \frac{\arctan tx}{x(x+1)} dx$, $t > 0$, or $I(t) = \int_0^1 \frac{\sin tx}{\sqrt{1-x}} dx$ are improper integrals with a parameter t . In the first example, $b = \infty$ and the improper integral is of the first type. In the second case, $b = 1$ and the improper integral is of the second type. To study such an integral, we simply need to study the nature of a limit at the singular point b . Namely, let $I(t) = \int_{a(t)}^b f(x, t) dx$ with b as the unique singular point. In fact, $I(t) = \lim_{x \rightarrow b} F(x, t)$, where $F(x, t) = \int_{a(t)}^x f(u, t) du$. If for any fixed $t \in J$, this limit exists, i.e. the usual improper integral $\int_{a(t)}^b f(x, t) dx$ is convergent, we say that our improper integral with parameter t is *simple convergent*. If the limit

$$I(t) = \lim_{x \rightarrow b} F(x, t) = \lim_{x \rightarrow b} \int_{a(t)}^x f(u, t) du$$

is a uniform limit at b (a limit point of K) w.r.t. parameter t , we say that our improper integral is *uniformly convergent*. It is clear that a uniformly convergent integral is also a simple convergent one. Let us give a list with the above results, initial stated for limits of functions with parameters, applied here to the fixed integral $I(t) = \int_{a(t)}^b f(x, t)dx$, with a parameter t . We shall always assume that $f(x, t)$ is defined on $K \times J$, where K and J are intervals and that f is continuous with respect to x on K . Recall that $a : J \rightarrow K$ is a function defined on J with values in K . The following theorem is simply a translation of the results obtained in general for limits of functions with parameters in our particular case of limits of functions of the type $F(x, t) = \int_{a(t)}^x f(u, t)du$, with u in K , between $a(t)$ and $x \in K$. This is why we do not give a complete proof for the next theorem.

THEOREM 57. *With the above notation and hypotheses, one has the following statements:*

a) *The integral $I(t) = \int_{a(t)}^b f(x, t)dx$, with singularity b (a limit point of K), is uniformly convergent if and only if for any small real number $\varepsilon > 0$ there is a neighborhood V_b of b in K , such that $\left| \int_{x'}^{x''} f(x, t)dx \right| < \varepsilon$ for any x', x'' in V_b (Cauchy criterion).*

b) *If $I(t) = \int_{a(t)}^b f(x, t)dx$ is uniformly convergent on J , then $I(t)$ is continuous on J (continuity theorem).*

c) *If $I(t) = \int_{a(t)}^b f(x, t)dx$ is uniformly convergent on J and $[a, c] \subset K$, then*

$$\int_a^c \left[\int_{a(t)}^b f(x, t)dx \right] dt = \int_{a(t)}^b \left[\int_a^c f(x, t)dt \right] dx.$$

(Fubini theorem). *If a or c is the unique singularity of $I(t)$ in \overline{K} , the set of the limit points of K in $\mathbb{R} \cup \{\pm\infty\}$, and if all the integrals with parameters t or x are uniformly convergent, then the last formula is also true.*

d) *Let us assume that the integral $I(t) = \int_{a(t)}^b f(x, t)dx$ is convergent and, in addition, that the integral $H(t) = \int_{a(t)}^b \frac{\partial f}{\partial t}(x, t)dx$ is uniformly convergent. Then $I(t)$ is differentiable and:*

$$(2.8) \quad I'(t) = \int_{a(t)}^b \frac{\partial f}{\partial t}(x, t)dx - a'(t)f(a(t), t),$$

for any $t \in J$ (Leibniz formula).

e) (Weierstrass test) Let $I(t) = \int_a^b f(x, t)dx$, $a \in \mathbb{R}$, be an improper integral with a parameter t and with singularity b . If there exists a function $s(x)$, $s : K \rightarrow \mathbb{R}$ such that $|f(x, t)| \leq s(x)$ for any $x \in K$, $t \in J$ and if the improper integral $\int_a^b s(x)dx$ is convergent, then $I(t)$ is uniformly convergent.

PROOF. Let us prove for instance Leibniz formula d).

Let $F(x, t) = \int_{a(t)}^x f(u, t)du$. Since the integral $I(t) = \int_{a(t)}^b f(x, t)dx$ is convergent, the function $F(x, t)$ has as a limit at b , exactly the function $I(t)$. Since the integral $H(t) = \int_{a(t)}^b \frac{\partial f}{\partial t}(x, t)dx$ is uniformly convergent, the function $L(x, t) = \int_{a(t)}^x \frac{\partial f}{\partial t}(u, t)du$ has as a uniform limit the function $H(t)$. Applying theorem 56 we get that

$$\begin{aligned} I'(t) &= \lim_{x \rightarrow b} \frac{\partial F}{\partial t}(x, t) = \lim_{x \rightarrow b} \left[\int_{a(t)}^x \frac{\partial f}{\partial t}(u, t)du - a'(t)f(a(t), t) \right] = \\ &= \int_{a(t)}^b \frac{\partial f}{\partial t}(x, t)du - a'(t)f(a(t), t). \end{aligned}$$

Here we just applied Leibniz formula for the proper integral $\int_{a(t)}^x f(u, t)du$ with parameter t .

Let us prove now Weierstrass test e). In order to prove that the improper integral $I(t) = \int_a^b f(x, t)dx$ with parameter t is uniformly convergent, we use Cauchy criterion a) of the same theorem. Let $\varepsilon > 0$ be a small real number and let V_b be a neighborhood of b in K such that for any $x', x'' \in V_b$ one has $\left| \int_{x'}^{x''} s(x)dx \right| < \varepsilon$ (here we used the fact that the improper integral $\int_a^b s(x)dx$ is convergent). Since

$$\left| \int_{x'}^{x''} f(x, t)dx \right| \leq \int_{x'}^{x''} |f(x, t)| dx \leq \int_{x'}^{x''} s(x)dx < \varepsilon,$$

we finally derive that $\left| \int_{x'}^{x''} f(x, t)dx \right| < \varepsilon$ for any $x', x'' \in V_b$. Applying again the Cauchy criterion a), we get that the integral $I(t)$ is uniformly convergent. \square

Let us use Leibniz formula d) of this last theorem (for improper integrals with a parameter) to compute the integral $I(t) = \int_0^\infty \frac{\arctan tx}{x(1+x^2)}dx$, $t > 0$. We can easily see that this integral is uniformly convergent (for applying Leibniz formula this is not necessarily!). To see this we write

$$\left| \frac{\arctan tx}{x(1+x^2)} \right| \leq \frac{\pi}{2} \frac{1}{x(1+x^2)}.$$

Since the improper integral $\frac{\pi}{2} \int_1^\infty \frac{1}{x(1+x^2)} dx$ is convergent (apply p -test with $p = 3$), Weierstrass test e) in the above theorem says that $\int_1^\infty \frac{\arctan tx}{x(1+x^2)} dx$ is uniformly convergent. Since $\lim_{x \rightarrow 0} \frac{\arctan tx}{x(1+x^2)} = t$, the integral $\int_0^1 \frac{\arctan tx}{x(1+x^2)} dx$ is a proper integral. It is easy to see that a sum between a proper integral and an uniformly convergent improper integral is also an uniformly convergent improper integral (prove this!). Thus

$$I(t) = \int_0^\infty \frac{\arctan tx}{x(1+x^2)} dx = \int_0^1 \frac{\arctan tx}{x(1+x^2)} dx + \int_1^\infty \frac{\arctan tx}{x(1+x^2)} dx$$

is an uniformly convergent integral. We also need that the integral

$$H(t) = \int_0^\infty \frac{\partial}{\partial t} \left[\frac{\arctan tx}{x(1+x^2)} \right] dx = \int_0^\infty \frac{1}{(1+x^2)(1+t^2x^2)} dx$$

of the derivative function with respect to t be uniformly convergent. Since

$$\begin{aligned} \int_0^\infty \frac{1}{(1+x^2)(1+t^2x^2)} dx &= \int_0^1 \frac{1}{(1+x^2)(1+t^2x^2)} dx + \\ &+ \int_1^\infty \frac{1}{(1+x^2)(1+t^2x^2)} dx \end{aligned}$$

and since $\int_0^1 \frac{1}{(1+x^2)(1+t^2x^2)} dx$ is a proper integral for $t \neq 0$, it is sufficient to prove that $\int_1^\infty \frac{1}{(1+x^2)(1+t^2x^2)} dx$ is uniformly convergent. Since

$$\frac{1}{(1+x^2)(1+t^2x^2)} \leq \frac{1}{1+x^2}$$

and since $\int_1^\infty \frac{1}{(1+x^2)} dx$ is convergent (test p for $p = 2$), applying again Weierstrass test e) we get that $\int_1^\infty \frac{1}{(1+x^2)(1+t^2x^2)} dx$ is uniformly convergent. Now we can apply Leibniz formula for $a(t) = 0$ and $b = \infty$:

$$I'(t) = \int_0^\infty \frac{1}{(1+x^2)(1+t^2x^2)} dx.$$

But

$$\frac{1}{(1+x^2)(1+t^2x^2)} = \frac{1}{1-t^2} \cdot \frac{1}{1+x^2} - \frac{t^2}{1-t^2} \cdot \frac{1}{1+t^2x^2}$$

for any $t \neq 1$. Thus,

$$\begin{aligned} I'(t) &= \frac{1}{1-t^2} \int_0^\infty \frac{1}{1+x^2} dx - \frac{t^2}{1-t^2} \int_0^\infty \frac{1}{1+t^2x^2} dx = \\ &= \frac{1}{1-t^2} \arctan x \Big|_0^\infty - \frac{t}{1-t^2} \arctan tx \Big|_0^\infty = \frac{\pi}{2} \frac{1}{1+t}. \end{aligned}$$

Taking the primitive on both sides in

$$I'(t) = \frac{\pi}{2} \frac{1}{1+t},$$

we get $I(t) = \frac{\pi}{2} \ln(1+t) + C$, where C does not depend on t . Since $I(0) = 0$, we obtain $C = 0$. Thus, $I(t) = \frac{\pi}{2} \ln(1+t)$ for any $t > 0$, $t \neq 1$. Since both functions $I(t)$ and $\frac{\pi}{2} \ln(1+t)$ are continuous with respect to t , the equality is true even for $t = 1$.

Let us use now Weierstrass test e) of this last theorem to prove the uniform convergence of the integral $I(t) = \int_1^\infty \frac{\sin tx}{x^2} dx$. For this, let $\varepsilon > 0$ be a small real number and let $M > 0$ be a sufficiently large real number such that if $x', x'' > M$ then $\int_{x'}^{x''} \frac{1}{x^2} dx < \varepsilon$ (here we use the fact that the integral $\int_1^\infty \frac{1}{x^2} dx$ is convergent, see test p). But

$$\left| \int_{x'}^{x''} \frac{\sin tx}{x^2} dx \right| \leq \int_{x'}^{x''} \frac{|\sin tx|}{x^2} dx \leq \int_{x'}^{x''} \frac{1}{x^2} dx < \varepsilon$$

for any $x', x'' > M$. Thus, the Weierstrass test e) tells us that the integral $I(t) = \int_1^\infty \frac{\sin tx}{x^2} dx$ is uniformly convergent.

Now we give some applications to the effective computation of some classes of integrals with parameters.

EXAMPLE 57. *Let us compute the value of the following integral with two parameters α and β :*

$$(2.9) \quad I(\alpha, \beta) = \int_0^\infty \frac{e^{-\alpha x^2} - e^{-\beta x^2}}{x} dx, \alpha, \beta > 0.$$

Since

$$\lim_{x \rightarrow 0} \frac{e^{-\alpha x^2} - e^{-\beta x^2}}{x} = \frac{0}{0} = \lim_{x \rightarrow 0} \frac{-2\alpha x e^{-\alpha x^2} - 2\beta x e^{-\beta x^2}}{1} = 0,$$

for any fixed α and β , the integral has only $b = \infty$ as a singularity. Considering successively $I(\alpha, \beta)$ as an integral with a parameter α and then, with a parameter β respectively, we can apply Leibniz formula separately for α and β respectively. Let us prove the simple convergence of $I(\alpha, \beta)$. Since

$$\lim_{x \rightarrow \infty} x^2 \frac{e^{-\alpha x^2}}{x} = 0, \quad \lim_{x \rightarrow \infty} x^2 \frac{e^{-\beta x^2}}{x} = 0,$$

if $\alpha, \beta > 0$, the p -test with $p = 2$ gives us the simple convergence of $I(\alpha, \beta)$. We need now the uniform convergence of

$$\frac{\partial I}{\partial \alpha} = \int_0^\infty \frac{\partial}{\partial \alpha} \left[\frac{e^{-\alpha x^2} - e^{-\beta x^2}}{x} \right] dx = - \int_0^\infty x e^{-\alpha x^2} dx.$$

For any fixed $\alpha_1 > 0$, this last integral is uniformly convergent on the interval $J = [\alpha_1, \infty)$. Indeed,

$$\left| xe^{-\alpha x^2} \right| = xe^{-\alpha x^2} \leq xe^{-\alpha_1 x^2}$$

and $\int_0^\infty xe^{-\alpha_1 x^2} dx$ is convergent (apply test p for $p = 2$), thus applying again Weierstrass test e) of theorem 57 we obtain that the integral $-\int_0^\infty xe^{-\alpha x^2} dx$ is uniformly convergent w.r.t. α . In the same way we can prove that the integral

$$\frac{\partial I}{\partial \beta} = \int_0^\infty \frac{\partial}{\partial \beta} \left[\frac{e^{-\alpha x^2} - e^{-\beta x^2}}{x} \right] dx = \int_0^\infty xe^{-\beta x^2} dx$$

is uniformly convergent on any interval $[\beta_1, \infty)$ with respect to β if $\beta_1 > 0$ is fixed. Thus

$$(2.10) \quad \frac{\partial I}{\partial \alpha} = - \int_0^\infty xe^{-\alpha x^2} dx = \frac{1}{2\alpha} e^{-\alpha x^2} \Big|_0^\infty = -\frac{1}{2\alpha}$$

and

$$(2.11) \quad \frac{\partial I}{\partial \beta} = \int_0^\infty xe^{-\beta x^2} dx = -\frac{1}{2\beta} e^{-\beta x^2} \Big|_0^\infty = \frac{1}{2\beta}.$$

Integrating with respect to α in the equality (2.10) we get

$$I(\alpha, \beta) = -\frac{1}{2} \ln \alpha + C(\beta).$$

Let us introduce this expression of $I(\alpha, \beta)$ in formula (2.11):

$$C'(\beta) = \frac{1}{2\beta},$$

so $C(\beta) = \frac{1}{2} \ln \beta + k$, where k does not depend either on α or on β . Hence

$$I(\alpha, \beta) = -\frac{1}{2} \ln \alpha + \frac{1}{2} \ln \beta + k = \frac{1}{2} \ln \frac{\beta}{\alpha} + k.$$

We see that if $\alpha = \beta$, $I(\alpha, \alpha) = 0 = k$. Finally, $I(\alpha, \beta) = \frac{1}{2} \ln \frac{\beta}{\alpha}$.

This last example can be generalized in the following form.

THEOREM 58. (Froullani's integrals) Let $f : [0, \infty) \rightarrow \mathbb{R}$ be a continuous bounded function with $f(\infty) = \lambda$. For any $0 < a < b$ we define

$$I(a, b) = \int_0^\infty \frac{f(ax) - f(bx)}{x} dx.$$

a) Then the integral is simply convergent and

$$(2.12) \quad I(a, b) = [f(0) - f(\infty)] \ln \frac{b}{a}.$$

b) If in addition f is of class C^1 on $[0, \infty)$ and if for any $\varepsilon > 0$, $M > 0$ there is a continuous function $g(x)$, such that $|f'(xt)| \leq g(x)$ for all $x \in (0, \infty)$, $t \in [\varepsilon, M]$, and $\int_0^\infty g(x)dx$ is convergent, then $I(a, b)$ is uniformly convergent on any interval of the form $[\varepsilon, M]$ (i.e. $a, b \in [\varepsilon, M]$), where $0 < \varepsilon < M$.

PROOF. a) Let $0 < \delta < \Delta < \infty$ and let us estimate the integral

$$(2.13) \quad \int_{\delta}^{\Delta} \frac{f(ax) - f(bx)}{x} dx \stackrel{ax=z}{\underset{bx=z}{=}} \int_{a\delta}^{a\Delta} \frac{f(z)}{z} dz - \int_{b\delta}^{b\Delta} \frac{f(z)}{z} dz.$$

Since

$$\int_{a\delta}^{a\Delta} \frac{f(z)}{z} dz = \int_{a\delta}^{b\delta} \frac{f(z)}{z} dz + \int_{b\delta}^{a\delta} \frac{f(z)}{z} dz + \int_{a\delta}^{a\Delta} \frac{f(z)}{z} dz$$

and

$$\int_{b\delta}^{b\Delta} \frac{f(z)}{z} dz = \int_{b\delta}^{a\delta} \frac{f(z)}{z} dz + \int_{a\delta}^{a\Delta} \frac{f(z)}{z} dz + \int_{a\Delta}^{b\Delta} \frac{f(z)}{z} dz,$$

by subtraction these last two equalities we get

$$\int_{a\delta}^{a\Delta} \frac{f(z)}{z} dz - \int_{b\delta}^{b\Delta} \frac{f(z)}{z} dz = \int_{a\delta}^{b\delta} \frac{f(z)}{z} dz - \int_{a\Delta}^{b\Delta} \frac{f(z)}{z} dz.$$

Let us apply now the mean formula of theorem 22 to both of these last integrals. We obtain

$$(2.14) \quad \int_{\delta}^{\Delta} \frac{f(ax) - f(bx)}{x} dx = [f(\xi) - f(\eta)] \ln \frac{b}{a},$$

where $\xi \in [a\delta, b\delta]$ and $\eta \in [a\Delta, b\Delta]$. Let us make $\delta \rightarrow 0$ and $\Delta \rightarrow \infty$ in formula (2.14) we get

$$\int_0^\infty \frac{f(ax) - f(bx)}{x} dx = [f(0) - f(\infty)] \ln \frac{b}{a}.$$

b) Let us assume that f is of class C^1 on $[0, \infty]$ and let us denote by φ the function: $\varphi(t) = f(xt)$, $t \in [a, b]$, for a fixed $x \in (0, \infty)$. We apply Lagrange formula for this function φ on $[a, b]$:

$$\varphi(b) - \varphi(a) = \varphi'(c)(b - a),$$

or

$$f(bx) - f(ax) = f'(cx) \cdot x \cdot (b - a),$$

where $c \in (a, b)$. Thus, for $0 < \varepsilon < M$,

$$\left| \frac{f(ax) - f(bx)}{x} \right| \leq (b - a)g(x).$$

Since $(b-a) \int_0^\infty g(x) dx$ is convergent, Weierstrass test c) of theorem 57 tells us that $I(a, b) = \int_0^\infty \frac{f(ax)-f(bx)}{x} dx$ is uniformly convergent. \square

For instance,

$$I(a, b) = \int_0^\infty \frac{\arctan ax - \arctan bx}{x} dx = \frac{\pi}{2} \ln \frac{a}{b}.$$

Since $f(z) = \arctan z$ is of class C^1 on \mathbb{R} ,

$$f'(xt) = \frac{1}{1+x^2t^2} \leq \frac{1}{1+x^2\varepsilon^2} (= g(x))$$

for any $t \in [\varepsilon, M]$ with $[a, b] \subset [\varepsilon, M]$ and $\int_0^\infty \frac{1}{1+x^2\varepsilon^2} dx$ is convergent, we see that $I(a, b)$ is uniform convergent on $[\varepsilon, \infty)$ for any fixed $\varepsilon > 0$. But not always one can use Froullani's formula (2.12) even the integral is of the same form. For instance,

$$I(a, b) = \int_0^\infty \frac{\cos ax - \cos bx}{x} dx, 0 < a < b.$$

Here $f(z) = \cos z$ has no limit at $z = \infty$, so the above theorem cannot be applied. To compute it, we consider another integral with parameters:

$$J(a, k) = \int_0^\infty \frac{1 - \cos ax}{x} e^{-kx} dx, a > 0, k > 0.$$

Since the integral

$$\int_0^1 \frac{1 - \cos ax}{x} e^{-kx} dx$$

is a proper integral, the integral

$$\int_1^\infty \frac{1 - \cos ax}{x} e^{-kx} dx$$

is uniformly convergent with respect to a :

$$\left| \frac{1 - \cos ax}{x} e^{-kx} \right| \leq \frac{1}{x} e^{-kx}$$

and $\int_1^\infty \frac{1}{x} e^{-kx} dx$ is convergent, see test p , for $p = 2$ and also

$$\int_0^\infty e^{-kx} \sin ax dx$$

is uniformly convergent w.r.t. a :

$$|e^{-kx} \sin ax| \leq e^{-kx}$$

and $\int_0^\infty e^{-kx} dx$ is convergent, we can write (Leibniz's formula):

$$(2.15) \quad \frac{\partial J}{\partial a} = \int_0^\infty e^{-kx} \sin ax dx = \frac{a}{a^2 + k^2} \quad (\text{compute it two times by parts}).$$

Thus

$$J(a, k) = \int \frac{a}{a^2 + k^2} da = \frac{1}{2} \ln(a^2 + k^2) + C(k).$$

Making $a \rightarrow 0$, because of the continuity of $J(a, k)$ w.r.t. a (here we use the uniform continuity of J relative to a and theorem 57 b)), one has that $0 = \ln k + C(k)$, or $C(k) = -\ln k$. Thus

$$J(a, k) = \ln \frac{\sqrt{a^2 + k^2}}{k}.$$

If instead of a we put b , we get

$$\int_0^\infty \frac{1 - \cos bx}{x} e^{-kx} dx = \ln \frac{\sqrt{b^2 + k^2}}{k}.$$

But

$$\begin{aligned} I(a, b, k) &= \int_0^\infty \frac{\cos ax - \cos bx}{x} e^{-kx} dx = \\ &= \ln \frac{\sqrt{b^2 + k^2}}{k} - \ln \frac{\sqrt{a^2 + k^2}}{k} = \ln \frac{\sqrt{b^2 + k^2}}{\sqrt{a^2 + k^2}} \end{aligned}$$

for any $a, b, k > 0$. Since for any $k \in [\delta, \infty)$, with $\delta > 0$, the integral $I(a, b, k)$ is uniformly convergent w.r.t. k

$$\left(\left| \frac{\cos ax - \cos bx}{x} e^{-kx} \right| \leq \left| \frac{\cos ax - \cos bx}{x} e^{-\delta x} \right| \quad \text{and}$$

$$\int_0^\infty \frac{\cos ax - \cos bx}{x} e^{-\delta x} dx \text{ is convergent}),$$

fixing a $k_0 > 0$ and taking $0 < \delta < k_0$, we can apply again theorem 57 and find that $I(a, b, k)$ is continuous at k_0 as a function of k . Now we can make $k \rightarrow 0$ in the equality

$$(2.16) \quad \int_0^\infty \frac{\cos ax - \cos bx}{x} e^{-kx} dx = \ln \frac{\sqrt{b^2 + k^2}}{\sqrt{a^2 + k^2}}$$

and finally find that $\int_0^\infty \frac{\cos ax - \cos bx}{x} dx = \ln \frac{b}{a}$ for any $a, b > 0$. Is this last integral uniform convergent with respect to the parameters a and b ? To use formula 2.16 it is not a good idea because the integral $I(a, b, k)$ is uniformly convergent w.r.t. k only on any interval of the

type $[\delta, \infty)$ and not on the entire interval $(0, \infty)$. We shall prove now that the integral

$$I(a, b) = \int_0^{\infty} \frac{\cos ax - \cos bx}{x} dx = \ln \frac{b}{a}$$

is not uniformly convergent w.r.t. a and b (simultaneously), where $a, b \in (0, \infty)$. Suppose it is uniformly convergent. Applying theorem 57 b) we get for $a = \frac{1}{2n}$, $b = \frac{1}{n}$ and $n \rightarrow \infty$ that $0 = \ln 2$, a contradiction! Thus our integral cannot be uniformly convergent on $(0, \infty)$. It is an open problem for me if this integral is uniformly convergent on any interval of the type $[\delta, \infty)$, where $\delta > 0$. But on intervals of the type $[\delta, M]$, $0 < \delta < M$? These informations could not help us to compute the integral by Leibniz formula because the integral

$$\int_0^{\infty} \frac{\partial}{\partial a} \left[\frac{\cos ax - \cos bx}{x} \right] dx = - \int_0^{\infty} \sin ax dx$$

is not convergent!

EXAMPLE 58. (*Dirichlet's integral*) The following integral with a parameter β ,

$$I(\beta) = \int_0^{\infty} \frac{\sin \beta x}{x} dx$$

is very useful in different branches of science and technique. It was considered for the first time by the great German mathematician Johann Peter Gustave Lejeune Dirichlet in the XIX-th century. To prove its existence, for any fixed β , he invented the Dirichlet test (see theorem 39). In example 49 we just proved its simple convergence. In order to compute it we need it to be uniformly convergent. Even we had succeeded to prove such thing, Leibniz formula leads us to compute

$$\int_0^{\infty} \frac{\partial}{\partial \beta} \left[\frac{\sin \beta x}{x} \right] dx = \int_0^{\infty} \cos \beta x dx,$$

which is divergent! This is why Weierstrass invented an indirect method to compute this integral. To force the convergence to ∞ (0 is not a singular point!), Dirichlet considered the following more complicated integral with two parameters α, β :

$$(2.17) \quad D(\alpha, \beta) = \int_0^{\infty} e^{-\alpha x} \frac{\sin \beta x}{x} dx, \quad \alpha > 0, \beta \in \mathbb{R}.$$

It is easy to see that we can reduce ourselves to the case $\beta > 0$. It is also clear that the integral $D(\alpha, \beta)$ is uniformly convergent if $\alpha \in [\alpha_0, \infty)$,

$\beta > 0$, where α_0 is a fixed positive real number as small as we want. Indeed, since

$$\left| e^{-\alpha x} \frac{\sin \beta x}{x} \right| \leq \frac{e^{-\alpha_0 x}}{x},$$

since the integral $\int_1^\infty \frac{e^{-\alpha_0 x}}{x} dx$ is convergent (test p for $p = 2$) and since

$$\int_0^\infty e^{-\alpha x} \frac{\sin \beta x}{x} dx = \int_0^1 e^{-\alpha x} \frac{\sin \beta x}{x} dx + \int_1^\infty e^{-\alpha x} \frac{\sin \beta x}{x} dx,$$

the first integral being a proper one, Weierstrass test e) of theorem 57 tells us that the initial integral $D(\alpha, \beta)$ is uniformly convergent. To apply Leibniz formula of differentiating under the integral sign with respect to β (see theorem 57 d)) we also need to prove that the integral

$$T(\beta) = \int_0^\infty \frac{\partial}{\partial \beta} \left[e^{-\alpha x} \frac{\sin \beta x}{x} \right] dx = \int_0^\infty e^{-\alpha x} \cos \beta x dx = \frac{\alpha}{\beta^2 + \alpha^2}$$

is uniformly convergent with respect to β . Indeed,

$$|e^{-\alpha x} \cos \beta x| \leq e^{-\alpha x}$$

and $\int_0^\infty e^{-\alpha x} dx$ is convergent ($= \frac{1}{\alpha}$) implies the uniform convergence of $T(\beta)$ (Weierstrass test). Hence, Leibniz formula applied to $D(\alpha, \beta)$ as an improper integral with parameter β gives:

$$\frac{\partial D}{\partial \beta} = \int_0^\infty \frac{\partial}{\partial \beta} \left[e^{-\alpha x} \frac{\sin \beta x}{x} \right] dx = \frac{\alpha}{\beta^2 + \alpha^2}.$$

Integrating with respect to β we get:

$$D(\alpha, \beta) = \int_0^\infty e^{-\alpha x} \frac{\sin \beta x}{x} dx = \arctan \frac{\beta}{\alpha} + C(\alpha).$$

The uniform continuity w.r.t. $\beta > 0$ makes $D(\alpha, \beta)$ a continuous function of β ((see theorem 57 b)). Thus $D(\alpha, 0) = 0 = C(\alpha)$ for any $\alpha > 0$. Hence we finally obtain

$$(2.18) \quad D(\alpha, \beta) = \int_0^\infty e^{-\alpha x} \frac{\sin \beta x}{x} dx = \arctan \frac{\beta}{\alpha}.$$

The uniform continuity of $D(\alpha, \beta)$ with respect to $\alpha \in [\alpha_0, \infty)$ for any $\alpha_0 > 0$, makes $D(\alpha, \beta)$ continuous with respect to $\alpha > 0$ (see theorem 57 b)). Thus $D(0, \beta) = \int_0^\infty \frac{\sin \beta x}{x} dx = \frac{\pi}{2}$. Now Dirichlet's integral is completely computed:

$$(2.19) \quad \int_0^\infty \frac{\sin \beta x}{x} dx = \begin{cases} \frac{\pi}{2}, & \text{if } \beta > 0 \\ 0, & \text{if } \beta = 0 \\ -\frac{\pi}{2}, & \text{if } \beta < 0. \end{cases}$$

Dirichlet's integral is very useful in the computation of other integrals. For instance,

$$I = \int_0^{\infty} \frac{\sin^2 5x}{x^2} dx = \lim_{x \rightarrow \infty} \int_0^x \frac{\sin^2 5u}{u^2} du = -\lim_{x \rightarrow \infty} \int_0^x \sin^2 5u \left(\frac{1}{u}\right)' du =$$

$$(2.20) \quad -\lim_{x \rightarrow \infty} \left[\sin^2 5u \cdot \frac{1}{u} \Big|_0^x - 10 \int_0^x \frac{\sin 5u \cos 5u}{u} du \right].$$

Since

$$\lim_{u \rightarrow 0} \frac{\sin^2 5u}{u} = 5 \lim_{u \rightarrow 0} \frac{\sin 5u}{5u} \cdot \lim_{u \rightarrow 0} \sin 5u = 5 \cdot 1 \cdot 0 = 0,$$

$\sin^2 5u \cdot \frac{1}{u} \Big|_0^x = \frac{\sin^2 5x}{x}$ and $10 \int_0^x \frac{\sin 5u \cos 5u}{u} du = 5 \int_0^x \frac{\sin 10u}{u} du$. Thus the value of I from (2.20) becomes

$$I = -\lim_{x \rightarrow \infty} \frac{\sin^2 5x}{x} - 5 \int_0^{\infty} \frac{\sin 10u}{u} du.$$

Since $\left| \frac{\sin^2 5x}{x} \right| \leq \frac{1}{x}$, we find that the limit is equal to 0. Looking at the Dirichlet's integral we see that $\int_0^{\infty} \frac{\sin 10u}{u} du = \frac{\pi}{2}$ (here $\beta = 10$). Thus, $I = -\frac{5\pi}{2}$.

EXAMPLE 59. (Euler-Poisson integral) The famous integral $J = \int_0^{\infty} e^{-x^2} dx$, which appears in Probability and Statistics whenever we work with the Gauss-Laplace distribution and in many other places of Mathematics, Mechanics, etc. is called the Euler-Poisson integral. To compute it (the p -test for $p = 2$ assure us on the convergence!) let us introduce a parameter u and a new variable t . Let us make a change of variables $x \leftrightarrow t$, $x = ut$ in J . We get $J = u \int_0^{\infty} e^{-u^2 t^2} dt$. Thus

$$e^{-u^2} J = u e^{-u^2} \int_0^{\infty} e^{-u^2 t^2} dt.$$

Let us integrate this last equality with respect to u and then let us change the order of integration (see Fubini's theorem for improper integrals, theorem 57 c); verify the uniform convergence!):

$$J \int_0^{\infty} e^{-u^2} du = J^2 = \int_0^{\infty} u e^{-u^2} du \cdot \int_0^{\infty} e^{-u^2 t^2} dt =$$

$$= \int_0^{\infty} \left(\int_0^{\infty} e^{-u^2(t^2+1)} u du \right) dt = \int_0^{\infty} -\frac{1}{2(t^2+1)} e^{-(1+t^2)u^2} \Big|_0^{\infty} dt =$$

$$= \frac{1}{2} \int_0^{\infty} \frac{1}{1+t^2} dt = \frac{1}{2} \arctan t \Big|_0^{\infty} = \frac{\pi}{4}.$$

Hence

$$(2.21) \quad J = \int_0^{\infty} e^{-x^2} dx = \frac{\sqrt{\pi}}{2}$$

If we put $x = \sqrt{t}u$, u being a new variable and $t > 0$ a parameter, we get

$$(2.22) \quad \int_0^{\infty} e^{-tu^2} du = \frac{1}{\sqrt{t}} \frac{\sqrt{\pi}}{2}.$$

EXAMPLE 60. (Fresnel's integrals) The following integrals $I_1 = \int_0^{\infty} \sin x^2 dx$ and $I_2 = \int_0^{\infty} \cos x^2 dx$ are called Fresnel's integrals. Let us see that I_1 is convergent and then we shall compute it. Since $I_1 = \lim_{A \rightarrow \infty} \int_0^A \sin x^2 dx$, let us evaluate $\int_0^A \sin x^2 dx$. Let us change the variable x with $u = x^2$, i.e. $x = \sqrt{u}$. Thus, $dx = \frac{1}{2\sqrt{u}} du$ and the last integral becomes $\int_0^{A^2} \frac{\sin u}{2\sqrt{u}} du$. In this last case $u = 0$ is a singularity point for this integral. But the integral is convergent because $\lim_{u \rightarrow 0, u > 0} u^{\frac{1}{2}} \frac{\sin u}{2\sqrt{u}} = 0$, $q = 1/2$ in the q -test, thus the integral is convergent. Moreover $I_1 = \int_0^{\infty} \frac{\sin u}{2\sqrt{u}} du$. It is also convergent at ∞ . Indeed, one can apply Dirichlet test (see theorem 39) and see that $\int_1^{\infty} \frac{\sin u}{2\sqrt{u}} du$ is convergent. We just proved that $\int_0^1 \frac{\sin u}{2\sqrt{u}} du$ ($A = 1$) is convergent, so

$$I_1 = \int_0^1 \frac{\sin u}{2\sqrt{u}} du + \int_1^{\infty} \frac{\sin u}{2\sqrt{u}} du$$

is also convergent. To compute $I_1 = \int_0^{\infty} \frac{\sin u}{2\sqrt{u}} du$ let us force the convergence to ∞ with a more complicated improper integral with a parameter k :

$$(2.23) \quad J_1(k) = \int_0^{\infty} \frac{\sin u}{2\sqrt{u}} e^{-ku} du.$$

It is easy to see that this integral is uniformly convergent on any interval of the type $[\delta, \infty)$ with $\delta > 0$ ($\left| \frac{\sin u}{2\sqrt{u}} e^{-ku} \right| \leq \frac{e^{-\delta u}}{\sqrt{u}}$, $\int_0^{\infty} \frac{e^{-\delta u}}{\sqrt{u}} du$ is convergent so we can apply Weierstrass test e) of theorem 57). This implies that the function $k \rightarrow J_1(k)$ is continuous on $(0, \infty)$ and it can be extended by continuity with $J_1(0) = \int_0^{\infty} \frac{\sin u}{2\sqrt{u}} du$ on $[0, \infty)$. Since $\int_0^{\infty} e^{-ut^2} dt = \frac{1}{\sqrt{u}} \frac{\sqrt{\pi}}{2}$ (see formula (2.22)), we can put instead of $\frac{1}{\sqrt{u}}$ in formula (2.23) the expression $\frac{2}{\sqrt{\pi}} \int_0^{\infty} e^{-ut^2} dt$. Thus we get

$$J_1(k) = \int_0^{\infty} \frac{\sin u}{2\sqrt{u}} e^{-ku} du = \frac{1}{\sqrt{\pi}} \int_0^{\infty} \left[e^{-ku} \sin u \int_0^{\infty} e^{-ut^2} dt \right] du =$$

$$= \frac{1}{\sqrt{\pi}} \int_0^{\infty} \left[\int_0^{\infty} \sin u \cdot e^{-u(k+t^2)} dt \right] du.$$

We now apply Fubini theorem (see theorem 57 c)) to change the order of integration:

$$J_1(k) = \frac{1}{\sqrt{\pi}} \int_0^{\infty} \left[\int_0^{\infty} \sin u \cdot e^{-u(k+t^2)} du \right] dt.$$

From formula (2.15), $\int_0^{\infty} e^{-kx} \sin ax dx = \frac{a}{a^2+k^2}$, we get

$$\int_0^{\infty} \sin u \cdot e^{-u(k+t^2)} du = \frac{1}{1+(k+t^2)^2}.$$

Thus

$$J_1(k) = \frac{1}{\sqrt{\pi}} \int_0^{\infty} \frac{1}{1+(k+t^2)^2} dt.$$

The continuity of $J_1(k)$ on $[0, \infty)$ finally implies that

$$(2.24) \quad I_1 = J_1(0) = \int_0^{\infty} \frac{\sin u}{2\sqrt{u}} du = \frac{1}{\sqrt{\pi}} \int_0^{\infty} \frac{1}{1+t^4} dt.$$

To compute $\int_0^{\infty} \frac{1}{1+t^4} dt$ we need the decomposition of $\frac{1}{1+t^4}$ into simple fractions. Since

$$t^4 + 1 = (t^2 + 1)^2 - 2t^2 = (t^2 + 1 - t\sqrt{2})(t^2 + 1 + t\sqrt{2}),$$

we get

$$\frac{1}{1+t^4} = \frac{At+B}{t^2+1-t\sqrt{2}} + \frac{Ct+D}{t^2+1+t\sqrt{2}},$$

where $A = -\frac{1}{2\sqrt{2}}$, $C = \frac{1}{2\sqrt{2}}$, $B = D = \frac{1}{2}$. Hence

$$\begin{aligned} \int \frac{1}{1+t^4} dt &= \frac{A}{2} \int \frac{(2t-\sqrt{2})}{t^2+1-t\sqrt{2}} dt + \frac{A+\sqrt{2}B}{\sqrt{2}} \int \frac{1}{t^2+1-t\sqrt{2}} dt + \\ &+ \frac{C}{2} \int \frac{(2t+\sqrt{2})}{t^2+1+t\sqrt{2}} dt + \frac{B\sqrt{2}-C}{\sqrt{2}} \int \frac{1}{t^2+1+t\sqrt{2}} dt = \\ &= \frac{1}{4\sqrt{2}} \ln \frac{t^2+1+t\sqrt{2}}{t^2+1-t\sqrt{2}} - \frac{1}{4} \int \frac{1}{\left(t-\frac{1}{\sqrt{2}}\right)^2 + \frac{1}{2}} d\left(t-\frac{1}{\sqrt{2}}\right) + \\ &+ \frac{1}{4} \int \frac{1}{\left(t+\frac{1}{\sqrt{2}}\right)^2 + \frac{1}{2}} d\left(t+\frac{1}{\sqrt{2}}\right) = \frac{1}{4\sqrt{2}} \ln \frac{t^2+1+t\sqrt{2}}{t^2+1-t\sqrt{2}} + \\ &+ \frac{1}{4} \cdot \sqrt{2} \tan^{-1}(\sqrt{2}t-1) + \frac{1}{4} \cdot \sqrt{2} \tan^{-1}(\sqrt{2}t+1). \end{aligned}$$

Thus,

$$\int_0^{\infty} \frac{1}{1+t^4} dt = 0 + \frac{\sqrt{2}}{4} \left[\frac{\pi}{2} + \frac{\pi}{4} + \frac{\pi}{2} - \frac{\pi}{4} \right] = \frac{\pi}{2\sqrt{2}}.$$

Finally, $I_1 = \frac{1}{\sqrt{\pi}} \cdot \frac{\pi}{2\sqrt{2}} = \frac{1}{2}\sqrt{\frac{\pi}{2}}$. We leave as an exercise for the reader to prove that $I_2 = \int_0^{\infty} \cos x^2 dx$ is also $\frac{1}{2}\sqrt{\frac{\pi}{2}}$.

REMARK 19. Sometimes we meet the following situation. Let K be an interval $[a, b]$ in $\mathbb{R} \cup \{\pm\infty\}$ and let $J = [t_0, T]$ be an interval in $\mathbb{R} \cup \{\infty\}$ such that $t_0 \in \mathbb{R}$. Let $f(x, t)$ be a function of two variables defined on $K \times J$ such that it is of class C^1 on $K \times J$. Let $I(t) = \int_a^b f(x, t) dx$ be an improper integral with a parameter t with a or b , or both of them as its unique singular points. Assume that for any $\delta > 0$, $\delta < T - t_0$, the integrals $I(t)$ and $L(t) = \int_a^b \frac{\partial f}{\partial t}(x, t) dx$ are uniformly convergent w.r.t. t on $[t_0 + \delta, T]$. We also assume that $I(t_0) = \int_a^b f(x, t_0) dx$ is convergent and that $L(t) = \int_a^b \frac{\partial f}{\partial t}(x, t) dx$ is bounded in any neighborhood $[t_0, t_0 + \delta]$ of t_0 . Then the function $t \rightarrow I(t) = \int_a^b f(x, t) dx$ is well defined on $[t_0, \infty)$ and it is continuous on this interval. Indeed, since $I(t)$ is uniformly convergent on any interval of the type $[t_0 + \delta, T]$ it is continuous on $(t_0, T]$ (see theorem 57 b)). Now we prove that we can "extend by continuity" this continuous function $I(t)$, $t \in (t_0, T]$ to the entire interval $[t_0, T]$ by putting $I(t_0) = \int_a^b f(x, t_0) dx$. Thus we want to prove the continuity of I at t_0 in $[t_0, T]$. Take a sequence $\{t_n\}_{n \geq 1}$, $t_n \in (t_0, T]$ and $t_n \rightarrow t_0$. Let us evaluate the difference $I(t_n) - I(t_0)$, when $n \rightarrow \infty$. For any fixed $x \in (a, b)$, let us apply Lagrange formula for the function $t \rightarrow f(x, t)$ on the interval $[t_0, t_n]$:

$$f(x, t_n) - f(x, t_0) = \frac{\partial f}{\partial t}(x, c_{x, t_n})(t_n - t_0),$$

where $c_{x, t_n} \in [t_0, t_n]$. Thus,

$$I(t_n) - I(t_0) = \int_a^b [f(x, t_n) - f(x, t_0)] dx = (t_n - t_0) \int_a^b \frac{\partial f}{\partial t}(x, c_{x, t_n}) dx$$

is convergent to 0 when $n \rightarrow \infty$ because $\int_a^b \frac{\partial f}{\partial t}(x, c_{x, t_n}) dx$ is bounded around the point t_0 . Hence $I(t)$ is also continuous at $t = t_0$.

For instance, let $I(t) = \int_0^{\infty} \frac{\sin x}{x} e^{-tx} dx$, $t \in [0, \infty)$. It is not difficult to prove that all conditions which appears in remark 19 are satisfied for $t_0 = 0$. Thus we can say that I is also continuous at $t = 0$. Its value $I(0) = \int_0^{\infty} \frac{\sin x}{x} dx = \frac{\pi}{2}$ (see Dirichlet's integral 2.19).

EXAMPLE 61. Let us study and compute the following integral

$I(\alpha, \beta) = \int_0^1 \frac{x^\alpha - x^\beta}{\ln x} dx$, $\alpha, \beta > -1$. For this let us formally write

$$I(\alpha, \beta) = \int_0^1 \frac{x^\alpha - 1}{\ln x} dx - \int_0^1 \frac{x^\beta - 1}{\ln x} dx.$$

It is sufficient to prove that any of this last two integrals are proper integrals (do it!). Thus $I(\alpha, \beta)$ is a proper integral and

$$\begin{aligned} \int_0^1 \frac{x^\alpha - x^\beta}{\ln x} dx &= \int_0^1 \left(\int_\beta^\alpha x^t dt \right) dx = \int_\beta^\alpha \left(\int_0^1 x^t dx \right) dt = \\ &= \int_\beta^\alpha \frac{x^{t+1}}{t+1} \Big|_0^1 dt = \int_\beta^\alpha \frac{1}{t+1} dt = \ln \frac{\alpha+1}{\beta+1}. \end{aligned}$$

Here we just applied Fubini theorem 52, because all integrals which appear can be considered proper integrals.

3. Euler's functions gamma and beta

A polynomial function, $P(x) = a_0 + a_1x + \dots + a_nx^n$, $x \in \mathbb{R}$, a_0, \dots, a_n are fixed real numbers, a rational function $R(x) = \frac{P(x)}{Q(x)}$, where $P(x)$, $Q(x)$ are polynomial functions, an exponential function $f(x) = a^x$, $a > 0, a \neq 1$, a logarithmic function $f(x) = \log_a x$, $x > 0, a > 0, a \neq 1$, a power function $f(x) = x^\alpha$, $x > 0, \alpha \in \mathbb{R}$, a trigonometric function $f(x) = \sin x, \cos x, \tan x, \cot x$, or their inverses, a composition of these previous ones, all of these functions are called *elementary functions*. We know that all these elementary functions are very useful in many branches of applied mathematics. The first function which is not elementary but is very useful in many applications of mathematics is the gamma function of L. Euler (1707 – 1783). It is also called Euler's function of the second type. Its formal definition is the following:

DEFINITION 13.

$$(3.1) \quad \Gamma(x) = \int_0^\infty t^{x-1} e^{-t} dt, \quad x \in (0, \infty).$$

We see that this function is in fact an improper integral with a parameter x . In this case we must begin with a proof of its existence. We shall prove something more.

THEOREM 59. As an improper integral with a parameter x , the gamma function $\Gamma(x) = \int_0^\infty t^{x-1} e^{-t} dt$, $x \in (0, \infty)$ is uniformly convergent on every closed subinterval $[\delta, M] \subset (0, \infty)$. In particular, it is

continuous and differentiable on $(0, \infty)$. Moreover, it is of class C^∞ on $(0, \infty)$ and its derivative of order k is

$$(3.2) \quad \Gamma^{(k)}(x) = \int_0^\infty t^{x-1} (\ln t)^k e^{-t} dt, \quad x \in (0, \infty)$$

for any $k = 0, 1, \dots$.

PROOF. Since for $k = 0$ in formula (3.2) we obtain the definition formula (3.1), we fix a k in \mathbb{N} and we shall prove the statement of theorem for a more general case of improper integral $\Gamma^{(k)}(x) = \int_0^\infty t^{x-1} (\ln t)^k e^{-t} dt$, $x \in (0, \infty)$ with parameter t . Let us formally write:

$$\Gamma^{(k)}(x) = \Gamma_1^{(k)}(x) + \Gamma_2^{(k)}(x),$$

where

$$\Gamma_1^{(k)}(x) = \int_0^1 t^{x-1} (\ln t)^k e^{-t} dt$$

and

$$\Gamma_2^{(k)}(x) = \int_1^\infty t^{x-1} (\ln t)^k e^{-t} dt.$$

If we could prove that these two last improper integrals with parameter x are uniformly convergent on $[\delta, M]$, their sum $\Gamma^{(k)}(x)$ would also be uniformly convergent on the same interval. Let us start with $\Gamma_1^{(k)}(x)$. It is an improper integral of the second type with a singular point $t = 0$. Since

$$|t^{x-1} (\ln t)^k e^{-t}| \leq t^{\delta-1} |\ln t|^k e^{-t} = t^{\delta-1} \left(\ln \frac{1}{t} \right)^k e^{-t},$$

applying Weierstrass test e) of theorem 57, it will be enough to prove the convergence of the integral $\int_0^1 t^{\delta-1} \left(\ln \frac{1}{t} \right)^k e^{-t} dt$. We can assume that δ is sufficiently small (we prove the uniform convergence on a larger interval if we diminish δ !), for instance that $0 < \delta < 1$. Let us fix now a number q such that $0 < q < 1$, $q + \delta - 1 > 0$ and another small number ε with $0 < \varepsilon < \frac{q-1+\delta}{k}$. We did this such that the following limit to be 0!

$$(3.3) \quad \lim_{t \rightarrow 0, t > 0} t^q t^{\delta-1} \left(\ln \frac{1}{t} \right)^k e^{-t} = \lim_{t \rightarrow 0, t > 0} t^q t^{\delta-1} t^{-k\varepsilon} \frac{\left(\ln \frac{1}{t} \right)^k}{\left(\frac{1}{t} \right)^{k\varepsilon}}.$$

But we know that function $\ln z$ goes to ∞ whenever $z \rightarrow \infty$ slower than any positive power of z , i.e. $\lim_{z \rightarrow \infty} \frac{\ln z}{z^\varepsilon} = 0$ (prove it again!). By

putting $z = \frac{1}{t}$, when $t \rightarrow 0$, $t > 0$, we get that $\frac{\left(\ln \frac{1}{t} \right)^k}{\left(\frac{1}{t} \right)^{k\varepsilon}} \rightarrow 0$, whenever

$t \rightarrow 0, t > 0$. Thus, in formula (3.3) we finally obtain:

$$\lim_{t \rightarrow 0, t > 0} t^q t^{\delta-1} \left(\ln \frac{1}{t} \right)^k e^{-t} = \lim_{t \rightarrow 0, t > 0} t^{q+\delta-1-k\varepsilon} \cdot 0 = 0,$$

because $q + \delta - 1 - k\varepsilon > 0$ (see here why we wanted ε to verify the inequalities: $0 < \varepsilon < \frac{q-1+\delta}{k}!$). Now, the q -test (see theorem 45) tells us that the improper integral $\int_0^1 t^{\delta-1} \left(\ln \frac{1}{t} \right)^k e^{-t} dt$ is convergent and that $\Gamma_1^{(k)}(x) = \int_0^1 t^{x-1} (\ln t)^k e^{-t} dt$ is uniformly convergent.

Let us prove now that $\Gamma_2^{(k)}(x) = \int_1^\infty t^{x-1} (\ln t)^k e^{-t} dt$ is also uniformly convergent. Since our integral is improper of the first type, we apply again Weierstrass test e) of theorem 57:

$$|t^{x-1} (\ln t)^k e^{-t}| \leq t^{M-1} (\ln t)^k e^{-t}.$$

It remains to prove that the improper integral $\int_1^\infty t^{M-1} (\ln t)^k e^{-t} dt$ is convergent. Let us apply the p -test (see theorem 38):

$$\lim_{t \rightarrow \infty} t^p t^{M-1} (\ln t)^k e^{-t} = \lim_{t \rightarrow \infty} \frac{t^p t^{M-1} t^k}{e^t} \left(\frac{\ln t}{t} \right)^k = 0$$

for any p because the exponential function e^t goes faster to ∞ than any power of t , i.e. $\lim_{z \rightarrow \infty} \frac{t^\alpha}{e^t} = 0$ (prove it again!). Take for instance $p = 2$ and the test p tells us that the integral is convergent. Now the proof of the theorem is complete. \square

Two problems arise: 1) Is our improper integral $\Gamma(x) = \int_0^\infty t^{x-1} e^{-t} dt$, uniform convergent on an interval of the type $(0, M]$, for $M > 0$? The answer is no. Indeed, for any $0 < \eta < 1$ one has:

$$(3.4) \quad \int_0^\eta t^{x-1} e^{-t} dt \geq e^{-\eta} \int_0^\eta t^{x-1} dt = e^{-\eta} \frac{\eta^x}{x} \rightarrow \infty,$$

whenever $x \rightarrow 0$. Thus, it is not possible for a given small $\varepsilon > 0$ to find a $\eta, 0 < \eta < 1$, such that

$$\left| \int_0^\eta t^{x-1} e^{-t} dt \right| < \varepsilon$$

for any $x \in (0, M]$ because the quantity on the left goes to ∞ when x becomes closer and closer to 0 (see formula (3.4)).

The second problem: 2) Is our integral $\Gamma(x) = \int_0^\infty t^{x-1} e^{-t} dt$ uniformly convergent on an interval of the type $[M, \infty)$, where $M > 0$? The answer is also no. Indeed, for any fixed $N > 1$,

$$\int_N^\infty t^{x-1} e^{-t} dt \geq N^{x-1} \int_N^\infty e^{-t} dt = N^{x-1} e^{-N} \rightarrow \infty,$$

when $x \rightarrow \infty$. Thus, for a given small $\varepsilon > 0$ it is not possible to find a sufficiently large $N > 1$ such that $\int_N^\infty t^{x-1}e^{-t}dt < \varepsilon$ for any $x \in [M, \infty)$.

One of the most important property of Euler gamma function is that one which refers to the "generalization" of the factorial function $f(n) = n!$, defined only on the set of natural numbers. Namely, $\Gamma(n) = (n-1)!$ for any $n \in \mathbb{N}$, $n > 0$. This formula will appear as a consequence of a more general recurrence property.

THEOREM 60. (*basic properties of gamma*)

1) $\Gamma(1) = 1$.

2) $\Gamma(2) = 1$.

3) $\Gamma(x) = (x-1)\Gamma(x-1)$ for any $x > 1$ (*simple recurrence formula or simple reduction formula*).

4) $\Gamma(x) = (x-1)(x-2)\dots(x-n)\Gamma(x-n)$ for any fixed $n \in \mathbb{N}$, $n \geq 1$ and for any $x > n$ (*general recurrence formula or reduction formula*)

5) *It is sufficient to know the values of Γ on the interval $(0, 1]$.*

6) $\Gamma(n) = (n-1)!$ for any $n \in \mathbb{N}$, $n > 0$.

7) $\Gamma(x)\Gamma(1-x) = \frac{\pi}{\sin \pi x}$, $x \in (0, 1)$ (*complementaries formula*).

8) *It is sufficient to know the values of Γ on the interval $(0, \frac{1}{2}]$ and $\Gamma(\frac{1}{2}) = \sqrt{\pi}$.*

9) $\int_0^\infty y^{p-1}e^{-ty}dy = \frac{\Gamma(p)}{t^p}$, $t > 0$, $p > 0$.

PROOF. Property 7) cannot be proved here because its proof is either too long or it is shorter but involves a lot of higher mathematics.

Let us prove the other statements.

1) $\Gamma(1) = \int_0^\infty e^{-t}dt = -e^{-t} \Big|_0^\infty = 1$.

2)

$$\begin{aligned} \Gamma(2) &= \int_0^\infty te^{-t}dt = \int_0^\infty t(-e^{-t})'dt \quad \text{by parts} \\ &= -te^{-t} \Big|_0^\infty + \int_0^\infty e^{-t}dt = 0 + 1 = 1. \end{aligned}$$

3)

$$\begin{aligned} \Gamma(x) &= \int_0^\infty t^{x-1}e^{-t}dt = \int_0^\infty t^{x-1}(-e^{-t})'dt = \\ &= -t^{x-1}e^{-t} \Big|_0^\infty + (x-1) \int_0^\infty t^{x-2}e^{-t}dt = (x-1)\Gamma(x-1) \end{aligned}$$

or

$$(3.5) \quad \Gamma(x) = (x-1)\Gamma(x-1)$$

for any $x > 1$.

4) We simply apply the simple recurrence formula n times:

$$\begin{aligned}\Gamma(x) &= (x-1)\Gamma(x-1) = (x-1)(x-2)\Gamma(x-2) = \\ &= (x-1)(x-2)(x-3)\Gamma(x-3) = \dots \\ &= (x-1)(x-2)\dots(x-n)\Gamma(x-n).\end{aligned}$$

5) We know that Archimede's axiom says that any $x > 0$ belongs to an interval of the type $(n, n+1]$, where $n \in \mathbb{N} = \{0, 1, 2, \dots\}$. Thus, $x-n \in (0, 1)$ and formula

$$(3.6) \quad \Gamma(x) = (x-1)(x-2)\dots(x-n)\Gamma(x-n)$$

reduces the computation of $\Gamma(x)$ to the computation of $\Gamma(x-n)$, where $x-n \in (0, 1)$.

6) The formula $\Gamma(n+1) = n!$ immediately appears if we put in formula (3.6) $x = n+1$. Put then $n-1$ instead of n in this last obtained formula, etc.

8) In 5) we saw how to reduce the computation of $\Gamma(x)$ to the computation of gamma at a subunitary value $z = x-n$. Assume that $z > \frac{1}{2}$. Then $1-z < \frac{1}{2}$ and, using the complementaries formula 7) we get:

$$\Gamma(z) = \frac{\pi}{\Gamma(1-z) \sin \pi z}.$$

If we put $x = \frac{1}{2}$ in the complementaries formula, we get $\Gamma(\frac{1}{2}) = \sqrt{\pi}$. Another way to compute $\Gamma(\frac{1}{2})$ is to use directly the definition of $\Gamma(\frac{1}{2})$:

$$\begin{aligned}\Gamma\left(\frac{1}{2}\right) &= \int_0^\infty t^{-\frac{1}{2}} e^{-t} dt \stackrel{t=z^2}{=} 2 \int_0^\infty z^{-1} e^{-z^2} z dz = \\ &= 2 \int_0^\infty e^{-z^2} dz = 2 \cdot \frac{\sqrt{\pi}}{2} = \sqrt{\pi},\end{aligned}$$

because $\int_0^\infty e^{-z^2} dz = \frac{\sqrt{\pi}}{2}$ (Euler-Poisson integral-see example 59).

9) In $\Gamma(p) = \int_0^\infty z^{p-1} e^{-z} dz$ we put $z = ty$, where y is the new variable and t is a positive parameter. Thus, $\Gamma(p) = t^p \int_0^\infty y^{p-1} e^{-ty} dy$ or $\int_0^\infty y^{p-1} e^{-ty} dy = \frac{\Gamma(p)}{t^p}$. \square

$$\text{For instance, } \Gamma\left(\frac{7}{2}\right) = \frac{5}{2}\Gamma\left(\frac{5}{2}\right) = \frac{5}{2} \cdot \frac{3}{2} \cdot \Gamma\left(\frac{3}{2}\right) = \frac{5}{2} \cdot \frac{3}{2} \cdot \frac{1}{2}\Gamma\left(\frac{1}{2}\right) = \frac{15\sqrt{\pi}}{8}.$$

EXAMPLE 62. (moment of order k) The following integral

$M_k = \int_{-\infty}^\infty x^k e^{-x^2} dx$ is called in Statistics and in Mechanics a moment of order k (...of something!). If k is odd $M_k = 0$ (Why?). If $k = 2n$ is even, then

$$M_{2n} = 2 \int_0^\infty x^{2n} e^{-x^2} dx \stackrel{x^2=t}{=} \int_0^\infty t^{(n+\frac{1}{2})-1} e^{-t} dt = \Gamma\left(n + \frac{1}{2}\right).$$

Let us use now the general recurrence formula and get:

$$M_{2n} = \left(n - \frac{1}{2}\right) \left(n - \frac{3}{2}\right) \dots \frac{1}{2} \Gamma\left(\frac{1}{2}\right) = \frac{(2n-1)(2n-3)\dots 1}{2^{n-1}} \cdot \frac{\sqrt{\pi}}{2}.$$

Let us give some information in order to sketch the graphic of $\Gamma(x)$ (see Fig.1)

THEOREM 61. (derivatives and graphic for $\Gamma(x)$) Gamma function $\Gamma(x) = \int_0^\infty t^{x-1} e^{-t} dt$, $x \in (0, \infty)$ has the following additional properties:

- 1) $\Gamma''(x) > 0$, i.e. the graphic of Γ is a convex one (keep water!-see Fig.1)
- 2) Γ has a unique local extremum point, namely a minimum point $x_{\min} \in (1, 2)$ (see Fig.1)
- 3) Oy -axis is a vertical asymptote (see Fig.1)
- 4) $\lim_{x \rightarrow \infty} \Gamma(x) = \infty$. Moreover, $\Gamma(x) \rightarrow \infty$, whenever $x \rightarrow \infty$ as fast as $n! \rightarrow \infty$, when $n \rightarrow \infty$ (see Fig.1).

PROOF. 1) Formula (3.2) implies $\Gamma''(x) = \int_0^\infty t^{x-1} (\ln t)^2 e^{-t} dt > 0$ for any $x \in (0, \infty)$. Thus the function $\Gamma(x)$ is convex.

2) Since $\Gamma(1) = \Gamma(2) = 1$ (see theorem 60), Rolle's theorem (see for instance [Po], Th.36) says that there exists a point $x_{\min} \in (1, 2)$ such that $\Gamma'(x_{\min}) = 0$. Since $\Gamma''(x) > 0$, x_{\min} is a point of minimum for Γ . It is the unique extremum point for Γ . Otherwise, if there was another one $z \neq x_{\min}$, then $\Gamma'(z) = 0$ (Fermat's theorem-see for instance [Po], Th.35). Applying Rolle's theorem to the function $\Gamma'(x)$ on the interval with ends z and x_{\min} respectively, we would find a point y in this last interval such that $\Gamma''(y) = 0$, a contradiction, because $\Gamma''(x) > 0$ for any $x \in (0, \infty)$. Thus x_{\min} is the unique extremum point for Γ .

3) Let us compute

$$\lim_{x \rightarrow 0, x > 0} \Gamma(x) = \lim_{x \rightarrow 0, x > 0} \frac{\Gamma(x+1)}{x} = \frac{1}{+0} = \infty.$$

Here we just used the recurrence formula $\Gamma(x+1) = x\Gamma(x)$ (see theorem 60) and the continuity of Γ (see theorem 59).

4) The continuity of Γ , just used above, and the basic formula $\Gamma(n) = (n-1)!$ implies that

$$\lim_{x \rightarrow \infty} \Gamma(x) = \lim_{n \rightarrow \infty} \Gamma(n) = \lim_{n \rightarrow \infty} (n-1)! = \infty.$$

□

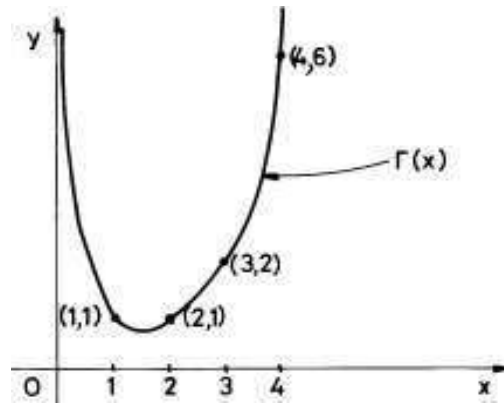

FIGURE 1

Another fundamental non-elementary function is the beta function of Euler or the first type Euler function. It is an improper integral with two parameters x and y . Its formal definition is:

DEFINITION 14.

$$(3.7) \quad B(x, y) = \int_0^1 t^{x-1}(1-t)^{y-1} dt, \quad x > 0, y > 0.$$

If $x \geq 1$ and $y \geq 1$ the beta function $B(x, y)$ is a proper integral with two parameters, i.e. it is convergent. The following result will clarify the other cases.

THEOREM 62. *The improper integral $B(x, y) = \int_0^1 t^{x-1}(1-t)^{y-1} dt$, $x > 0, y > 0$ is uniformly convergent on any strip of the form $[p_0, \infty) \times [q_0, \infty)$, where $p_0 > 0$ and $q_0 > 0$ (see Fig.2). In particular, the function $B(x, y)$ is continuous and even of class C^∞ on $(0, \infty) \times (0, \infty)$.*

PROOF. We see that $B(x, y)$ is an improper integral with two singularities: $t = 0$ and $t = 1$ when $x < 1$ and $y < 1$. This is why we consider the following decomposition (we separate these singularities):

$$B(x, y) = B_0(x, y) + B_1(x, y),$$

where

$$B_0(x, y) = \int_0^{\frac{1}{2}} t^{x-1}(1-t)^{y-1} dt$$

and

$$B_1(x, y) = \int_{\frac{1}{2}}^1 t^{x-1}(1-t)^{y-1} dt.$$

If we succeed to prove that both $B_0(x, y)$ and $B_1(x, y)$ are uniformly convergent on $[p_0, \infty) \times [q_0, \infty)$ for any $p_0, q_0 > 0$, then $B(x, y)$ itself would be uniformly convergent on $[p_0, \infty) \times [q_0, \infty)$. 1) Let us prove that $B_0(x, y)$ is uniformly convergent on $[p_0, \infty) \times [q_0, \infty)$. Since $t = 0$ is the only singularity in this last case, if $x < 1$, we can consider $p_0 < 1$ and $p_0 \leq x < 1$ (if $x \geq 1$ the integral is a proper one). Then

$$t^{x-1}(1-t)^{y-1} \leq t^{p_0-1}(1-t)^{y-1}.$$

Let us apply now the Weierstrass test c) of theorem 57 and try to prove that the integral $\int_0^{\frac{1}{2}} t^{p_0-1}(1-t)^{y-1} dt$ is convergent. For this we apply the q -test (the singularity is $t = 0$):

$$\lim_{t \rightarrow 0, t > 0} t^q t^{p_0-1}(1-t)^{y-1} = 1$$

for $q = 1 - p_0$, which is < 1 . Thus the integral is convergent and our integral $B_0(x, y)$ is uniformly convergent. 2) Let us now prove that the improper integral $B_1(x, y) = \int_{\frac{1}{2}}^1 t^{x-1}(1-t)^{y-1} dt$ is uniformly convergent. This time the integral has as its unique singular point the point $t = 1$. We can consider that $q_0 < 1$ (otherwise $x \geq 1$ and our integral would be a proper one, i.e. a convergent one). So $0 < q_0 < y < 1$ and we can try to apply Weierstrass test c) of theorem 57. Since

$$t^{x-1}(1-t)^{y-1} \leq t^{x-1}(1-t)^{q_0-1},$$

it remains to prove that the improper integral $\int_{\frac{1}{2}}^1 t^{x-1}(1-t)^{q_0-1} dt$ is convergent (the singularity is $t = 1$). Indeed, applying the same q -test for $q = 1 - q_0$ we get

$$\lim_{t \rightarrow 1, t < 1} (1-t)^{1-q_0} t^{x-1}(1-t)^{q_0-1} = 1.$$

Since $1 - q_0 < 1$, our last integral is convergent and consequently the integral $B_1(x, y)$ is uniformly convergent. Hence $B(x, y) = B_0(x, y) + B_1(x, y)$ is uniformly convergent on $[p_0, \infty) \times [q_0, \infty)$ for any $p_0, q_0 > 0$. The same type of proof can be done for the uniform convergence of $\int_0^1 \frac{\partial}{\partial x} [t^{x-1}(1-t)^{y-1}] dt$ or for $\int_0^1 \frac{\partial}{\partial y} [t^{x-1}(1-t)^{y-1}] dt$. Let us fix a point $(x_0, y_0) \in (0, \infty) \times (0, \infty)$ and let us choose $p_0, q_0 > 0$ such that $x_0 > p_0$ and $y_0 > q_0$. Thus, $(x_0, y_0) \in [p_0, \infty) \times [q_0, \infty)$ and, since the beta function $B(x, y)$ is uniformly convergent on $[p_0, \infty) \times [q_0, \infty)$, from theorem 57 b) and d), applied to $B_0(x, y)$ and to $B_1(x, y)$ separately, we see that $B(x, y)$ is continuous, differentiable and even of class C^∞ on $(0, \infty) \times (0, \infty)$ (work slowly everything!). \square

In the following result we put together the main properties of the function beta.

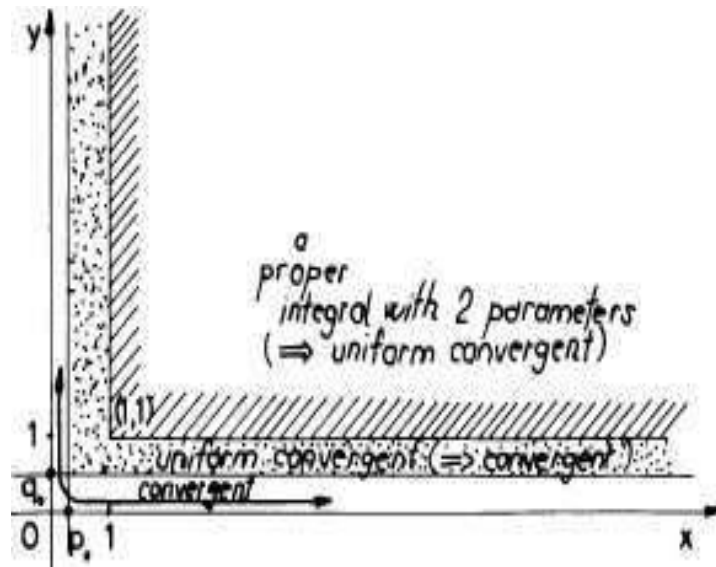

FIGURE 2

THEOREM 63. Let $B(x, y) = \int_0^1 t^{x-1}(1-t)^{y-1}dt$, $x > 0, y > 0$ be the beta function. Then

- 1) $B(x, y) = B(y, x)$ (symmetry).
- 2) $B(x, y+1) = \frac{y}{x+y}B(x, y)$ (reduction formula).
- 3) $B(x+1, y) = \frac{x}{x+y}B(x, y)$ (reduction formula).
- 4) $B(x, y) = \int_0^\infty \frac{u^{x-1}}{(1+u)^{x+y}} du$.
- 5) $B(x, y) = \int_0^\infty \frac{u^{y-1}}{(1+u)^{x+y}} du$.
- 6) $B(x, y) = \frac{\Gamma(x)\Gamma(y)}{\Gamma(x+y)}$ (Γ -reduction). This formula reduces the computations with function B to computations with function Γ .
- 7) $B(x, y) = 2 \int_0^{\frac{\pi}{2}} \sin^{2x-1} u \cos^{2y-1} u du$ (the trigonometric expression).

PROOF. First of all we want to remark that all the following computations are made in fact with proper integrals, then we take limits to obtain the improper integrals formulations. But we omit to specify this and we directly work with the improper form! Let us use this extremely excessive method only to prove 1).

$$\begin{aligned}
 B(x, y) &= \lim_{\varepsilon \rightarrow 0, \eta \rightarrow 1} \int_{\varepsilon}^{\eta} t^{x-1}(1-t)^{y-1} dt = \\
 &\stackrel{u=1-t}{=} \lim_{\varepsilon \rightarrow 0, \eta \rightarrow 1} \int_{1-\varepsilon}^{1-\eta} (1-u)^{x-1} u^{y-1} du =
 \end{aligned}$$

$$= \int_0^1 u^{y-1}(1-u)^{x-1} du = B(y, x).$$

2)

$$\begin{aligned} B(x, y+1) &= \int_0^1 t^{x-1}(1-t)^y dt = \int_0^1 \left(\frac{t^x}{x}\right)' (1-t)^y dt = \\ &= \left(\frac{t^x}{x}\right) (1-t)^y \Big|_0^1 + \frac{y}{x} \int_0^1 t^x (1-t)^{y-1} dt = \frac{y}{x} \int_0^1 t^{x-1} (1+t-1)(1-t)^{y-1} dt = \\ &= \frac{y}{x} \int_0^1 t^{x-1} (1-t)^{y-1} dt - \frac{y}{x} \int_0^1 t^{x-1} (1-t)^y dt = \frac{y}{x} B(x, y) - \frac{y}{x} B(x, y+1). \end{aligned}$$

Thus

$$\left[1 + \frac{y}{x}\right] B(x, y+1) = \frac{y}{x} B(x, y),$$

or

$$B(x, y+1) = \frac{y}{x+y} B(x, y).$$

3) We use now 1), 2) and again 1) to prove 3):

$$B(x+1, y) = B(y, x+1) = \frac{x}{x+y} B(y, x) = \frac{x}{x+y} B(x, y).$$

4) In $B(x, y) = \int_0^1 t^{x-1}(1-t)^{y-1} dt$ let us make the change of variable $t = \frac{u}{1+u} =$

$$t = \frac{u}{1+u} = 1 - \frac{1}{1+u}.$$

We simply get

$$B(x, y) = \int_0^\infty \left(\frac{u}{1+u}\right)^{x-1} \left(\frac{1}{1+u}\right)^{y-1} \frac{1}{(1+u)^2} du = \int_0^\infty \frac{u^{x-1}}{(1+u)^{x+y}} du.$$

5) If in the formula 4) we use the symmetry 1) we get:

$$B(x, y) = B(y, x) = \int_0^\infty \frac{u^{y-1}}{(1+u)^{y+x}} du,$$

i.e. formula 5).

6) In formula

$$(3.8) \quad \int_0^\infty y^{p-1} e^{-ty} dy = \frac{\Gamma(p)}{t^p}, \quad t > 0, p > 0.$$

of theorem 60 9) we simply put $t+1$ instead of t and $p+q$ instead of p (here $q > 0$). We get:

$$\frac{\Gamma(p+q)}{(t+1)^p} = \int_0^\infty y^{p+q-1} e^{-(t+1)y} dy.$$

Let us multiply this last equality by t^{p-1} and then let us integrate the obtained result with respect to t from 0 up to ∞ :

$$(3.9) \quad \Gamma(p+q) \int_0^\infty \frac{t^{p-1}}{(t+1)^{p+q}} dt = \int_0^\infty t^{p-1} \left[\int_0^\infty y^{p+q-1} e^{-(t+1)y} dy \right] dt.$$

It is not so difficult to verify the conditions of theorem 57 c) and apply Fubini's result, i.e. we change the order of integration in the equality (3.9). Moreover, we also use formula $\int_0^\infty \frac{t^{p-1}}{(t+1)^{p+q}} dt = B(p, q)$ just obtained in 4):

$$\Gamma(p+q)B(p, q) = \int_0^\infty y^{p+q-1} e^{-y} \left[\int_0^\infty t^{p-1} e^{-ty} dt \right] dy.$$

We use again formula (3.8) with t instead of y and y instead of t to compute the brackets inside the right side of the last equality:

$$\begin{aligned} \Gamma(p+q)B(p, q) &= \int_0^\infty y^{p+q-1} e^{-y} \frac{\Gamma(p)}{y^p} dy = \\ &= \Gamma(p) \int_0^\infty y^{q-1} e^{-y} dy = \Gamma(p)\Gamma(q), \end{aligned}$$

or

$$B(p, q) = \frac{\Gamma(p)\Gamma(q)}{\Gamma(p+q)}.$$

7) In the definition formula $B(x, y) = \int_0^1 t^{x-1}(1-t)^{y-1} dt$ of the function beta let us put $t = \sin^2 u$:

$$\begin{aligned} B(x, y) &= \int_0^{\frac{\pi}{2}} \sin^{2x-2} u \cdot \cos^{2y-2} u \cdot 2 \sin u \cdot \cos u du = \\ &= 2 \int_0^{\frac{\pi}{2}} \sin^{2x-1} u \cos^{2y-1} u du. \end{aligned}$$

□

The function beta is useful in the computation of some types of integrals. For instance, let us compute $I = \int_0^{\frac{\pi}{2}} \sin^7 x \sqrt{\cos x} dx$. It is very easy to put in formula 7) of the last theorem $2x-1 = 7$ and $2y-1 = \frac{1}{4}$. Thus $x = 4$ and $y = \frac{5}{8}$. Hence $I = \frac{1}{2} B(4, \frac{5}{8})$. Let us use now the Γ -reduction formula from the same last theorem and find:

$$\begin{aligned} I &= \frac{1}{2} B(4, \frac{5}{8}) = \frac{1}{2} \frac{\Gamma(4)\Gamma(\frac{5}{8})}{\Gamma(4+\frac{5}{8})} = \frac{1}{2} \frac{6 \cdot \Gamma(\frac{5}{8})}{(3+\frac{5}{8})(2+\frac{5}{8})(1+\frac{5}{8})(\frac{5}{8})\Gamma(\frac{5}{8})} = \\ &= \frac{3 \cdot 8^4}{29 \cdot 21 \cdot 13 \cdot 5}. \end{aligned}$$

Let us now compute $J = \int_0^\infty t^{\frac{1}{4}}(1+t)^{-2} dt$.

Formula $B(x, y) = \int_0^\infty \frac{u^{x-1}}{(1+u)^{x+y}} du$ from the above theorem can be used with $x - 1 = \frac{1}{4}$ and $x + y = 2$. Thus, $x = \frac{5}{4}$ and $y = \frac{3}{4}$. Hence

$$J = B\left(\frac{5}{4}, \frac{3}{4}\right) = \frac{\Gamma\left(\frac{5}{4}\right)\Gamma\left(\frac{3}{4}\right)}{\Gamma\left(\frac{5}{4} + \frac{3}{4}\right)} = \frac{\frac{1}{4}\Gamma\left(\frac{1}{4}\right) \cdot \Gamma\left(\frac{3}{4}\right)}{1}.$$

Let us use the complementary formula 7) of theorem 60 for $x = \frac{1}{4}$ and find $\Gamma\left(\frac{1}{4}\right) \cdot \Gamma\left(\frac{3}{4}\right) = \frac{\pi}{\sin\frac{\pi}{4}} = \frac{\pi\sqrt{2}}{2}$. Hence $J = \frac{\pi\sqrt{2}}{8}$.

EXAMPLE 63. *Another important integrals are $I_1(m) = \int_0^{\frac{\pi}{2}} \sin^m x dx$ and $I_2(m) = \int_0^{\frac{\pi}{2}} \cos^m x dx$. Let us compute $I_1(m)$ (here m is a natural number).*

$$I_1(m) = \int_0^{\frac{\pi}{2}} \sin^m x dx = \frac{1}{2} B\left(\frac{m+1}{2}, \frac{1}{2}\right) = \frac{1}{2} \frac{\Gamma\left(\frac{m+1}{2}\right)\Gamma\left(\frac{1}{2}\right)}{\Gamma\left(\frac{m+2}{2}\right)}.$$

If $m = 2k$ (even), then

$$\begin{aligned} I_1(2k) &= \frac{1}{2} \frac{\Gamma\left(k + \frac{1}{2}\right)\Gamma\left(\frac{1}{2}\right)}{\Gamma(k+1)} = \frac{1}{2} \frac{\left(k - \frac{1}{2}\right)\left(k - \frac{3}{2}\right) \dots \frac{1}{2} \left[\Gamma\left(\frac{1}{2}\right)\right]^2}{k!} = \\ &= \frac{\pi \cdot 1 \cdot 3 \cdot 5 \cdot \dots \cdot (2k-1)}{2^{k+1} k!}. \end{aligned}$$

If $m = 2k + 1$ (odd), then

$$\begin{aligned} I_1(2k+1) &= \frac{1}{2} \frac{\Gamma(k+1)\Gamma\left(\frac{1}{2}\right)}{\Gamma\left(k+1 + \frac{1}{2}\right)} = \frac{1}{2} \frac{k!\Gamma\left(\frac{1}{2}\right)}{\left(k + \frac{1}{2}\right)\left(k - \frac{1}{2}\right)\left(k - \frac{3}{2}\right) \dots \frac{1}{2}\Gamma\left(\frac{1}{2}\right)} = \\ &= \frac{2^k k!}{1 \cdot 3 \cdot 5 \cdot \dots \cdot (2k+1)}. \end{aligned}$$

We leave as an exercise to the reader to compute $I_2(m)$.

EXAMPLE 64. (*"Traian Lalescu" national contest, 2006, Romania*)
Let us compute $J_n = \int_a^b (x-a)^n (b-x)^n dx$. First of all let us change the variable x with $u = x - a$. Thus,

$$J_n = \int_0^{b-a} u^n (b-a-u)^n du = (b-a)^n \int_0^{b-a} u^n \left(1 - \frac{u}{b-a}\right)^n du.$$

Let us change again the variable u with $t = \frac{u}{b-a}$. Hence

$$\begin{aligned} J_n &= (b-a)^{2n+1} \int_0^1 t^n (1-t)^n dt = (b-a)^{2n+1} B(n+1, n+1) = \\ &= (b-a)^{2n+1} \frac{\Gamma(n+1)\Gamma(n+1)}{\Gamma(2n+2)} = (b-a)^{2n+1} \frac{(n!)^2}{(2n+1)!}. \end{aligned}$$

4. Problems and exercises

1. Prove that the function $f(x) = \int_x^\infty e^{-xy^2} dy$, $x > 0$ is well defined (the improper integral is convergent). Prove that the improper integral $\int_x^\infty e^{-xy^2} dy$ with a parameter $x > 0$ is uniformly convergent on any interval of the type $[x_0, \infty)$ with $x_0 > 0$. Compute $f'(x)$ and $f''(x)$ and prove that these improper integrals are uniformly convergent on intervals of the type $[x_0, \infty)$ with $x_0 > 0$.

2. Starting with equality $\int_0^\infty e^{-pt} dt = \frac{1}{p}$, $p > 0$, compute $\int_0^\infty t^n e^{-pt} dt$ for any $n = 1, 2, \dots$ (Justify all operations you do!).

3. Let $u(x, y) = \int_{-\infty}^\infty \frac{xf(z)}{x^2+(y-z)^2} dz$ be an improper integral with two parameters x, y . Study the convergence and the uniform convergence of $u(x, y)$. When can we compute $\frac{\partial^2 u}{\partial x^2}$ and $\frac{\partial^2 u}{\partial y^2}$? Prove that $\Delta u = \frac{\partial^2 u}{\partial x^2} + \frac{\partial^2 u}{\partial y^2} = 0$.

4. Starting with $\int_0^1 x^{a-1} dx = \frac{1}{a}$, $a > 1$, find $\int_0^1 x^{n-1} \ln^3 x dx$ for $n = 2, 3, \dots$.

5. Find an appropriate set of convergence for the following improper integrals with parameters, verify the conditions of Leibniz formula and apply it to compute them.

- $\int_0^\infty \frac{\arctan ax}{x(1+x^2)} dx$;
- $\int_0^{\frac{\pi}{2}} \frac{\arctan(\lambda \tan x)}{\tan x} dx$, $\lambda \geq 0$;
- $\int_0^\infty \frac{dx}{(x^2+\lambda)^{n+1}}$ (start with $\int_0^\infty \frac{dx}{(x^2+\lambda)}$ and compute its derivatives, many times);
- $\int_0^1 \frac{\ln(1-\alpha^2 x^2)}{x^2 \sqrt{1-x^2}} dx$, $|\alpha| < 1$;
- $\int_0^\pi \frac{\ln(1+\sin a \cos x)}{\cos x} dx$;
- $\int_0^\infty \frac{e^{-ax}-e^{-bx}}{x} dx$, $a > 0, b > 0$;
- $\int_0^\infty \frac{e^{-ax}-e^{-bx}}{x} \sin(mx) dx$, $a, b > 0$;
- $\int_0^{\frac{\pi}{2}} \ln \left(\frac{1+a \cos x}{1-a \cos x} \right) \frac{1}{\cos x} dx$, $|a| < 1$.

6. Prove that the famous Bessel's function $J_n(x) = \frac{2}{\pi} \int_0^\pi \cos(nt - x \sin t) dt$, $n = 0, 1, 2, \dots$, is a solution of the ordinary differential equation (Bessel's equation): $x^2 y'' + xy' + (x^2 - n^2)y = 0$.

7. Compute:

- $\lim_{x \rightarrow \infty} \frac{\int_0^{\sin x} e^{t^2} dt}{\int_0^{\tan x} e^{t^2} dt}$;
- $\lim_{x \rightarrow \infty} \frac{\int_0^x (\tan^{-1} t)^2 dt}{\sqrt{x^2+1}}$;
- $\lim_{x \rightarrow 0} \frac{\int_x^{x^2} e^{-t^2} dt}{\int_{x^3}^{x^2} e^{-t^2} dt}$;
- $\lim_{x \rightarrow 0} \frac{\int_{\sin x}^{x^2} e^{t^3} dt}{\int_1^{x+1} e^{t^2} dt}$.

8. Use Dirichlet's integral to compute:

- $\int_0^\infty \frac{\sin^3 x}{x} dx$;
- $\int_0^\infty \frac{\sin^4 x}{x} dx$;
- $\int_0^\infty \frac{\sin^2 x}{x^2} dx$;

Hint: $\sin 3x = (\sin x)(3 - 4 \sin^2 x)$; $\sin^4 x = (1 - \cos^2 x) \sin^2 x$;

9. Use informations on Euler's gamma and beta functions to compute:

- a) $\int_0^\infty t^{\frac{1}{4}}(1+t)^{-2}dt$; b) $\int_0^{\frac{\pi}{2}} \sin^3 x \cos^5 x dx$;
 c) $\int_0^{\frac{\pi}{2}} \sin^3 x \cos^2 x dx$; d) $\int_0^1 x^{-\frac{2}{3}}(1-x)^{-\frac{1}{3}}dx$;
 e) $\int_0^\infty x^6 e^{-x^2} dx$; f) $\int_{-\infty}^\infty x^n e^{-x^2} dx$, n a natural number;
 g) $\int_0^\infty e^{-x^3} dx$; h) $\int_0^1 t^3 \sqrt{1-t} dt$;
 i) $\int_0^1 (1-x^2)^{10} dx$; j) $\int_0^1 \frac{1}{\sqrt{1-x^3}} dx$; k) $\int_0^\infty \frac{x}{1+x^3} dx$; l) $\int_0^\infty \frac{1}{1+x^3} dx$;
 m) $\int_0^\infty \frac{dx}{(1+x^2)^2}$; n) $\int_0^\infty \frac{\sqrt[3]{x}}{1+x^2} dx$.

10) Compute:

- a) $\left(\int_t^{t^2} e^{-tx^2} dx \right)'' \Big|_{t=1}$; b) $\int_0^{\frac{\pi}{4}} \ln(1+t \cdot \tan x) dx$, $t \geq 0$; c) $\int_0^{\frac{\pi}{2}} \ln(\cos^2 x +$

$\sqrt{2} \sin^2 x) dx$ (Hint: Compute first of all $I(t) = \int_0^{\frac{\pi}{2}} \ln(\cos^2 x + t \sin^2 x) dx$, then put $t = \sqrt{2}$);

- d) $\int_0^\infty \frac{x^2}{1+x^4} dx$;

11) Prove that equality: $\Gamma\left(\frac{1}{2}\right) = \sqrt{\pi}$ implies equality:

$$\Gamma\left(n + \frac{1}{2}\right) = \frac{1 \cdot 3 \cdot 5 \cdots (2n-1)}{2^n} \sqrt{\pi} \text{ for any } n \in \mathbb{N}.$$

12) If $A = \Gamma\left(\frac{1}{6}\right)$ and $B = \Gamma\left(\frac{1}{3}\right)$, compute $\int_0^\infty \sqrt[6]{x}(1+x)^{-\frac{4}{3}} dx$ as an expression of A and B .

13) Reduce to computations with function Γ the following integral

$$\int_0^{\frac{\pi}{2}} \sin^{10} x \cos^{12} x dx.$$

14) Prove that the equality: $\Gamma\left(\frac{1}{2}\right) = \sqrt{\pi}$ implies the equality:

$$\int_0^\infty e^{-x^2} dx = \frac{\sqrt{\pi}}{2}.$$

15) Prove that $m = \int_{-\infty}^\infty x f(x) dx$ and $\sigma^2 = \int_{-\infty}^\infty (x-m)^2 f(x) dx$, where

$$f(x) = \frac{1}{\sigma\sqrt{2\pi}} e^{-\frac{(x-m)^2}{2\sigma^2}},$$

where $\sigma > 0$ and m is a fixed real number. This last function is called in Statistics the probability function of the Gauss-Laplace distribution. It models for instance the distribution of errors in a particular sequences of random measurements. m is called the *mean* and σ^2 is called the *variance* of this last distribution.

16) Compute $I(\lambda) = \int_0^\lambda \frac{\ln(1+\lambda x)}{1+x^2} dx$, $|\lambda| < 1$ and then compute

$$\int_0^{0.5} \frac{\ln(1+0.5x)}{1+x^2} dx.$$

CHAPTER 5

Line integrals

1. The mass of a wire. Line integrals of the first type.

DEFINITION 15. A 1-dimensional deformation or simply a deformation of an interval $I \subset \overline{\mathbb{R}} = \mathbb{R} \cup \{\pm\infty\}$ in the n -dimensional space \mathbb{R}^n is a vector function $\vec{r} : I \rightarrow \mathbb{R}^n$. For a $t \in I$, the vector $\vec{r}(t) = (x_1(t), \dots, x_n(t))$ is called the position vector of "the moving point" $M(x_1, x_2, \dots, x_n)$ at the moment t . Such a deformation is also called a parametric path in \mathbb{R}^n because it is uniquely determined by the n scalar functions $x_1 = x_1(t), \dots, x_n = x_n(t)$, where t is called a parameter. A parametric representation (parametrization) of this path is usually given in the following way:

$$(1.1) \quad \begin{cases} x_1 = x_1(t) \\ \cdot \\ \cdot \\ x_n = x_n(t) \end{cases}, t \in I.$$

The image $\vec{r}(I)$ in \mathbb{R}^n is commonly called the deformation of I through the deformation functions $x_1 = x_1(t), \dots, x_n = x_n(t)$ or simply a curve C in \mathbb{R}^n . This curve C is also called the support curve of the deformation \vec{r} . We say that the curve C is continuous if the vector function \vec{r} is continuous. We say that C is smooth if \vec{r} is of class C^1 on I , the function \vec{r} is injective (one-to-one) and "the velocity" $\vec{r}'(t) \neq 0$ for any $t \in I$. C is of class C^k on I if \vec{r} is of class C^k on I . The curve C is piecewise smooth if \vec{r} is smooth, but a finite set $\{t_1, t_2, \dots, t_m\} \subset I$. If C is continuous these last points are discontinuity points for \vec{r} , i.e. the curve is "interrupted" at these points. If C is continuous but it is not smooth because of the singular points $\{t_1, t_2, \dots, t_m\}$, we say that these last points are "corners" or "multiple points" for C . If $n = 2$, we denote the parametric representation of a curve C in \mathbb{R}^2 by $x = x(t), y = y(t), t \in I$. In this last case we say that C is a plane curve (a 2D-curve). If $n = 3$, we denote the parametric representation of a curve C in \mathbb{R}^3 by $x = x(t), y = y(t), z = z(t), t \in I$. We say that C is a space curve (a 3D-curve). In Fig.1 we see a piecewise smooth curve

with singular points M_1, M_2 and M_3 . These are the unique "corners" of this continuous curve.

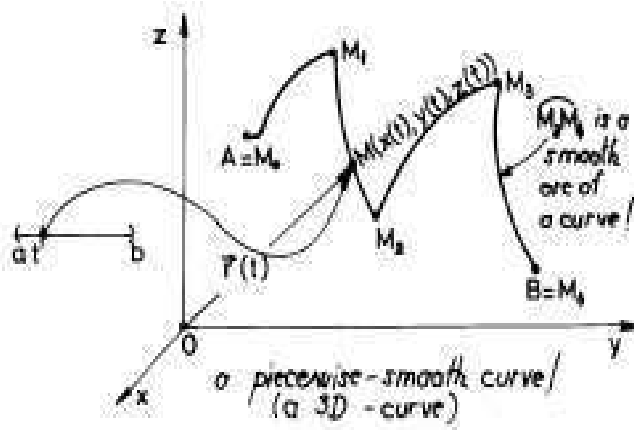

FIGURE 1

For instance, if $n = 1$ a continuous curve is an interval (why?). Let the following parametric path be in plane:

$$(1.2) \quad \begin{cases} x = R \cos t \\ y = R \sin t \end{cases}, t \in [0, 2\pi).$$

Thus, $\vec{r} : [0, 2\pi) \rightarrow \mathbb{R}^2$, $\vec{r}(t) = (R \cos t, R \sin t)$ is the corresponding parametric path. Whenever t runs from 0 up to 2π (without reaching it; otherwise the point $N(R, 0)$ would appear two times and our curve would not be smooth more-it would had a "double point"! the moving point $M(x(t), y(t))$ will describe a complete circle of radius R , "oriented" in the direct trigonometric direction, or counterwise clock sense (see Fig.2).

Let now $A(x_1, y_1)$ and $B(x_2, y_2)$ be two points in the Cartesian plane xOy (see Fig.3). The following parametrization:

$$(1.3) \quad \begin{cases} x = x(t) = x_1 + t(x_2 - x_1) \\ y = y(t) = y_1 + t(y_2 - y_1) \end{cases}, t \in [0, 1]$$

describes exactly the "oriented" closed segment $[AB]$.

Indeed, if $M(x(t), y(t))$ is a moving point on $[AB]$, for $t = 0$ it becomes A and for $t = 1$ it becomes B . It is an easy exercise of Analytical Geometry to see that any point on the segment $[AB]$ is of this type for a unique $t \in [0, 1]$. Since function $\vec{r}(t) = (x(t), y(t))$ is of class C^1 on $[0, 1]$, our closed segment is a plane or 2D-smooth curve. A smooth curve is also called a simple curve. Usually, in engineering, any curve

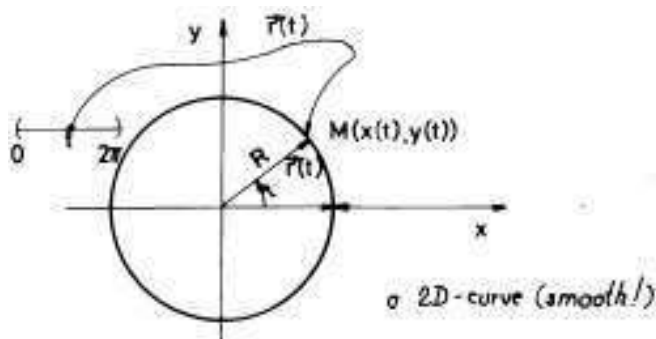

FIGURE 2

C will be a finite union of simple curves C_i , $i = 1, 2, \dots, N$, such that $C_i \cap C_j = \emptyset$ or a point for $i \neq j$.

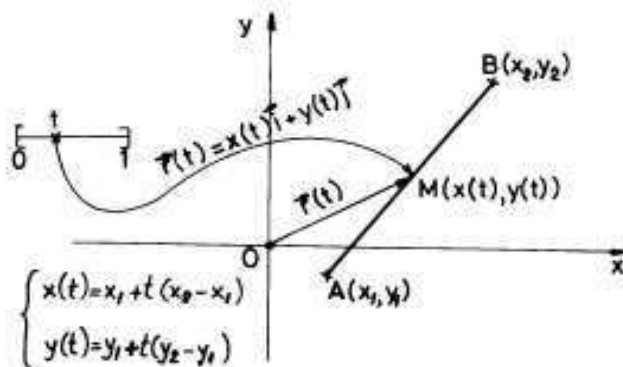

FIGURE 3

Let us come back to the circle (1.2), but instead of the interval $[0, 2\pi)$ we consider a new interval $[-\pi, \pi)$; this means that we start to go on the circle from $M(-R, 0)$, in the counterclockwise direction, up to we come back to M . This is the same with changing the variable t with a new one $v = t - \pi \in K = [-\pi, \pi)$. The new parametrization in the variable v is:

$$\begin{cases} \bar{x}(v) = -R \cos v \\ \bar{y}(v) = -R \sin v \end{cases}, t \in [0, 2\pi).$$

Now we change the variable $v \in K = [-\pi, \pi)$ with another one $u \in J = [-\infty, \infty)$ such that $\tan \frac{v}{2} = u$. Thus, the new parametrization of the same circle is:

$$(1.4) \quad \begin{cases} \tilde{x}(u) = -R \frac{1-u^2}{1+u^2} \\ \tilde{y}(u) = -R \frac{2u}{1+u^2} \end{cases}, u \in [-\infty, \infty) \subset \bar{\mathbb{R}} = \mathbb{R} \cup \{\pm\infty\}.$$

Here we have a new parametric path $\vec{q} : [-\infty, \infty) \rightarrow \mathbb{R}^2$, $\vec{q}(u) = (\tilde{x}(u), \tilde{y}(u))$, but the same curve, i.e. $\vec{q}([-\infty, \infty)) = \vec{r}([0, 2\pi))$. What is the relation between \vec{r} and \vec{q} ? If we describe the above substitutions we get $t = \pi + 2 \arctan u$. Hence the function $\lambda : J \rightarrow I$, $\lambda(u) = \pi + 2 \arctan u$ is a diffeomorphism, i.e. it is a bijection, it is of class C^1 on J and its inverse $\lambda^{-1}(t) = \tan \frac{t-\pi}{2}$ is also of class C^1 on I . Finally, $\vec{q}(u) = \vec{r}(\lambda(u))$, i.e. $\vec{q} = \vec{r} \circ \lambda$. Two paths \vec{r} and \vec{q} which can be obtained one from each other by a composition with a diffeomorphism are called *equivalent*. We see that the images of all equivalent paths are identical. Thus they give rise to one and the same curve. In the Advanced Mathematics the notion of a curve is an abstract object, namely the set of all equivalent parametric paths with a given one \vec{r} . In fact one works with a representative or with a representation of such an object, namely with a particular parametric path. Here we do not use such a sophisticated way to define a curve. We shall always identify the abstract curve with the image of a parametric path which is a representative of this curve. Thus a circle is an usual circle, a line is an usual line, etc. But, we always have to fix a particular parametrization of such a "curve" to work with. Instead of writing all the parameter equations in (1.1) to define a parametric curve $\vec{r} : I \rightarrow \mathbb{R}^3$, we simply write the couple (I, \vec{r}) and say: "Let the curve (or the deformation) (I, \vec{r}) ", etc.

DEFINITION 16. Let (I, \vec{r}) , $\vec{r}(t) = (x(t), y(t), z(t))$,
 (or $\vec{r}(t) = (x(t), y(t))$) be a 1-dimensional deformation in \mathbb{R}^3 (or in \mathbb{R}^2) and let $C = \vec{r}(I)$ be its support or the effective curve.
 Let $f : C \rightarrow \mathbb{R}$ be a scalar function defined on C . The triple (I, \vec{r}, f) is called a 3-D (a 2-D) wire or loaded curve with the density function f on it.

This is a mathematical general model for a "thread" or a wire, loaded with a mass $f(M)$ in each of its points (see Fig.4). In the following we consider only piecewise smooth wires (I, \vec{r}, f) , i.e. piecewise smooth curves loaded with almost continuous density functions f , i.e. functions f which are continuous on $C = \vec{r}(I)$ except maybe a finite number of points on C .

For the moment we restrict ourselves to a smooth finite and closed ($I = [a, b]$ is closed and finite) wire (I, \vec{r}, f) , where we denote by $[\widehat{AB}]$ the arc $C = \vec{r}(I)$, $A = \vec{r}(a)$, $B = \vec{r}(b)$ (see Fig.4). We also assume that f is continuous.

We know to compute the length $l([\widehat{AB}])$ (see formula (8.3), Ch.2) of the arc $[\widehat{AB}]$. If the density function f were a constant c , then the

which is a continuous deformation of the same interval $I = [a, b]$, together the density function \overline{f} is:

$$(1.5) \quad S((I, \overline{\mathbf{r}}, f); \Delta; \{\xi_i\}) = \sum_{i=1}^n f(x(\xi_i), y(\xi_i), z(\xi_i)) \left\| \overline{M_{i-1}M_i} \right\|.$$

Such a sum is said to be a Riemann sum for our wire $(I, \overline{\mathbf{r}}, f)$, which corresponds to the division Δ and the set of marking points $\{\xi_i\}$. It is clear enough that we can define such sums even in the case of an arbitrary wire $(I, \overline{\mathbf{r}}, f)$, not necessarily a smooth one.

DEFINITION 17. We say that the general wire $(I = [a, b], \overline{\mathbf{r}}, f)$ has a mass H (a real number) if for any small positive real number $\varepsilon > 0$, there exists a small positive real number δ (which depends on ε) such that $|H - S((I, \overline{\mathbf{r}}, f); \Delta; \{\xi_i\})| < \varepsilon$ for any division Δ of $[a, b]$ with $\|\Delta\| < \delta$ and for any set of marking points $\{\xi_i\}$, $\xi_i \in [t_{i-1}, t_i]$. This is also equivalent to saying that H is a unique point with the following property: "There exists a sequence of divisions $\{\Delta_n\}$, $\Delta_n \prec \Delta_{n+1}$ (the points of Δ_n are between the points of Δ_{n+1}) such that $\|\Delta_n\| \rightarrow 0$ and the sequence $\{S((I, \overline{\mathbf{r}}, f); \Delta_n; \{\xi_i^{(n)}\})\}$ is convergent to H for any choice of the set of marking points $\{\xi_i^{(n)}\}$ for the division Δ_n . This number H is said to be the line (curvilinear) integral of the first type of the function f on the curve $C = \overline{\mathbf{r}}([a, b])$. It is denoted by $\int_C f(x, y, z) ds$, where ds is called the element of length, i.e. the length of a "small" curvilinear arc $[\widehat{M_{i-1}M_i}]$ on C . If a wire $(I = [a, b], \overline{\mathbf{r}}, f)$ has a mass H we also say that the line integral $\int_C f(x, y, z) ds$ exists and it is equal to H . When $f = 1$, the mass H coincides with the length $l(C)$. Thus, in this last case, the length exists (C is rectifiable-see definition 8) and it is equal to $\int_C ds$.

We shall later give an example of a bounded wire even with $f = 1$ which has no finite mass (in this case the mass is equal to its length) at all. Since in engineering we usually do not meet such an exotic situation, we shall consider only piecewise smooth wires here, i.e. a finite union of smooth wires. Since taking masses is an additive process, we can restrict ourselves to the particular case of a smooth wire with a continuous density function. The following result give us a method to compute the mass of such a wire.

THEOREM 64. Let $(I = [a, b]; \overline{\mathbf{r}}; f)$, $\overline{\mathbf{r}}(t) = (x(t), y(t), z(t))$, be a smooth wire with f a continuous function. Then the line integral $\int_C f(x, y, z) ds$ of the first type exists (the mass of the wire exists) and

it can be computed by using the following formula:

$$(1.6) \quad \int_C f(x, y, z) ds = \int_a^b f(x(t), y(t), z(t)) \sqrt{x'^2(t) + y'^2(t) + z'^2(t)} dt.$$

As we just know (see formula (8.3), Ch.2), $ds = \sqrt{x'^2(t) + y'^2(t) + z'^2(t)} dt$.

PROOF. The proof follows the idea of the proof of the formula (8.3, Ch.2). Let us evaluate the Riemann sum $S((I, \vec{r}, f); \Delta; \{\xi_i\})$ of formula (1.5):

$$\begin{aligned} S((I, \vec{r}, f); \Delta; \{\xi_i\}) &= \sum_{i=1}^n f(x(\xi_i), y(\xi_i), z(\xi_i)) \left\| \overrightarrow{M_{i-1}M_i} \right\| = \\ &= \sum_{i=1}^n f(x(\xi_i), y(\xi_i), z(\xi_i)) \times \\ &\times \sqrt{[x(t_i) - x(t_{i-1})]^2 + [y(t_i) - y(t_{i-1})]^2 + [z(t_i) - z(t_{i-1})]^2}. \\ &= \sum_{i=1}^n f(x(\xi_i), y(\xi_i), z(\xi_i)) \times \\ &\sqrt{x'^2(c_i)(t_i - t_{i-1})^2 + y'^2(d_i)(t_i - t_{i-1})^2 + z'^2(e_i)(t_i - t_{i-1})^2}, \end{aligned}$$

where $c_i, d_i, e_i \in [t_{i-1}, t_i]$ (we applied Lagrange formula for each functions $x(t)$, $y(t)$ and $z(t)$ on the intervals $[t_{i-1}, t_i]$). Since the curve C is of class C^1 on $[a, b]$, functions $x'(t)$, $y'(t)$ and $z'(t)$ are continuous, so that we can use freely the approximations: $x'^2(c_i) \approx x'^2(\xi_i)$, $y'^2(d_i) \approx y'^2(\xi_i)$, $z'^2(e_i) \approx z'^2(\xi_i)$. Thus, our last Riemann sum becomes:

$$(1.7) \quad S((I, \vec{r}, f); \Delta; \{\xi_i\}) \approx \sum_{i=1}^n f(x(\xi_i), y(\xi_i), z(\xi_i)) \sqrt{x'^2(\xi_i) + y'^2(\xi_i) + z'^2(\xi_i)} (t_i - t_{i-1}).$$

The approximation here is better and better if the norm of the divisions Δ is smaller and smaller. Hence these Riemann sums have a unique limit point H if and only if the sums on the right in formula (1.7) have such a point H . But the sums on the right are nothing else than Riemann sums for the usual definite Riemann integral $\int_a^b f(x(t), y(t), z(t)) \sqrt{x'^2(t) + y'^2(t) + z'^2(t)} dt$. Thus, finally, this last integral exists and it is equal to H . Hence H exists and the formula (1.6) is true. \square

We can summarize all of these in the following two formulas:

$$(1.8) \quad \text{mass}([\widehat{AB}]) = \int_a^b f(x(t), y(t), z(t)) \sqrt{x'^2(t) + y'^2(t) + z'^2(t)} dt.$$

$$(1.9) \quad \text{length}([\widehat{AB}]) = \int_a^b \sqrt{x'^2(t) + y'^2(t) + z'^2(t)} dt.$$

If $C = C_1 \cup \dots \cup C_n$, where each curve C_1, \dots, C_n are smooth curves and $C_i \cap C_j = \emptyset$ or a point for $i \neq j$, then, by definition

$$\int_C f ds = \int_{C_1} f ds + \int_{C_2} f ds + \dots + \int_{C_n} f ds$$

Moreover, the mapping $f \rightarrow \int_C f ds$ is a linear mapping. It is easy to see that if C is smooth and f is continuous then there exists a point $c \in [a, b]$ such that

$$(1.10) \quad \int_C f ds = f(x(c), y(c), z(c)) \int_C ds = f(x(c), y(c), z(c)) \cdot \text{length}(C).$$

This is called the *mean formula* for line integrals of the first type.

We saw that any curve of class C^1 on an interval $[a, b]$ has a length, i.e. it is rectifiable. Here is an example of a continuous curve which is not rectifiable even I is a finite interval.

EXAMPLE 65. (*Koch's curve flake of snow*) We shall construct a sequence of curves (γ_n) , each curve being of class C^1 but a finite number of points (piecewise smooth curves) such that (γ_n) is uniformly convergent to a bounded curve (it can be embedded in a disc of a finite radius) γ which has an infinite length, i.e. it is not rectifiable. This last curve γ have no tangent line in any of its point. Let us construct the curve γ_1 , the polygonal line $(A_1A_2A_3A_4A_5)$ (see Fig.5).

Take a segment of a line, $[AB]$ of length $d > 0$ and divide it into 3 equal parts. Put $A_1 = A$ and $A_5 = B$. Then construct A_2, A_3, A_4 such that

$$\|\overrightarrow{A_1A_2}\| = \|\overrightarrow{A_2A_3}\| = \|\overrightarrow{A_3A_4}\| = \|\overrightarrow{A_4A_5}\| = \frac{d}{3}$$

and

$$\|\overrightarrow{A_1A_3}\| = \|\overrightarrow{A_5A_3}\| = \frac{d}{2} \frac{1}{\sin \alpha},$$

where for instance $\alpha = \frac{\pi}{6}$. On each side A_iA_{i+1} , $i = 1, 2, 3, 4$, we make the same construction as above by taking $\frac{d}{3}$ instead of d . Finally we obtain the polygonal line $(\gamma_2) = (B_1B_2 \dots B_{17})$ (see Fig.5). And so on. Let $R_1 = \frac{d}{2} \tan \alpha$, $\alpha = \frac{\pi}{6}$, be the height of the trapezoid $(A_1A_2A_4A_5)$. Since each trapezoid $(B_1B_2B_4B_5)$, $(B_5B_6B_8B_9)$, $(B_9B_{10}B_{12}B_{13})$ and

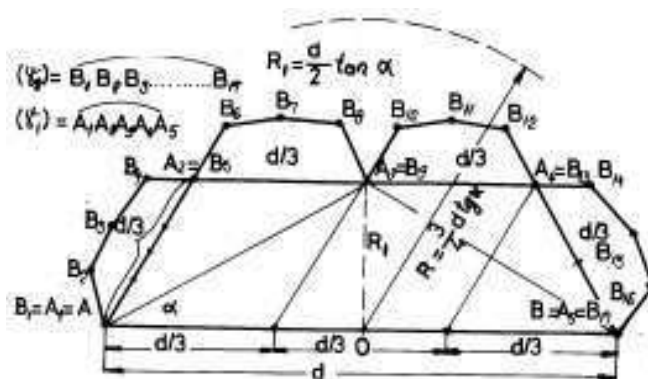

FIGURE 5

$(B_{13}B_{14}B_{16}B_{17})$ is similar to $(A_1A_2A_4A_5)$, the corresponding angles α have the same measure. Thus their heights are $R_2 = \frac{d}{2 \cdot 3} \tan \alpha$. The heights of the trapezoids which corresponds to (γ_3) is $R_3 = \frac{d}{2 \cdot 3^2} \tan \alpha$. For (γ_n) the corresponding R is $R_n = \frac{d}{2 \cdot 3^{n-1}} \tan \alpha$. Since $R_1 + R_2 + \dots + R_n + \dots = \frac{3}{4}d \tan \alpha$, $(\gamma) = \lim_{n \rightarrow \infty} (\gamma_n)$ is bounded. It is not so difficult to see that the length of (γ_n) is equal to $\frac{4^n}{3^n}d$. Hence the length of (γ) cannot be finite.

EXAMPLE 66. Let $[OABO]$ be a loaded frame like in Fig.6,

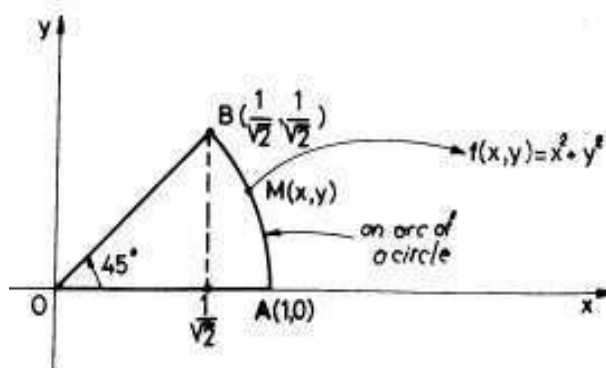

FIGURE 6

with the density function $f(x, y) = x^2 + y^2$. a) Find the perimeter of the frame. b) Find the mass of it. c) Find the mass center of the arc $[\widehat{AB}]$. d) Find the moment of inertia I_{Oy} of the segment $[OB]$ relative to the Oy -axis. Here is the solutions to these questions.

a) In spite of an easy elementary solution of this question, we shall apply here the above theory and formulas relative to the line integral of the first type. First of all we need to construct a parameterization of the frame. The support curve is not of class C^1 because it has 3 corners A, B and O . It is in fact a union of three smooth curves: $[OA]$, $[\widehat{AB}]$ and $[OB]$. Let us construct a parametrization for each of them.

$$(1.11) \quad [OB] : \begin{cases} x = t \\ y = t \end{cases}, t \in \left[0, \frac{1}{\sqrt{2}}\right]$$

$$(1.12) \quad [\widehat{AB}] : \begin{cases} x = \cos t \\ y = \sin t \end{cases}, t \in \left[0, \frac{\pi}{4}\right]$$

$$(1.13) \quad [OA] : \begin{cases} x = t \\ y = 0 \end{cases}, t \in [0, 1]$$

Now, $\text{length}([OB]) = \int_{[OB]} ds$, where $ds = \sqrt{x'^2 + y'^2} dt = \sqrt{2} dt$. Thus,

$$\text{length}([OB]) = \sqrt{2} \int_0^{\frac{1}{\sqrt{2}}} dt = 1.$$

Let us compute the length of the arc $[\widehat{AB}]$. In this case

$$ds = \sqrt{(-\sin t)^2 + \cos^2 t} dt = dt.$$

Thus,

$$\text{length}([\widehat{AB}]) = \int_{[\widehat{AB}]} ds = \int_0^{\frac{\pi}{4}} dt = \frac{\pi}{4}.$$

Now, the length of $[OA]$ is obviously 1 and the perimeter of the frame is equal to $1 + \frac{\pi}{4} + 1 = 2 + \frac{\pi}{4}$.

b) Since

$$\begin{aligned} \text{mass}[OABO] &= \text{mass}[OA] + \text{mass}[\widehat{AB}] + \text{mass}[OB] = \\ &= \int_{[OB]} (x^2 + y^2) ds + \int_{[\widehat{AB}]} (x^2 + y^2) ds + \int_{[OA]} (x^2 + y^2) ds = \\ &= \int_0^{\frac{1}{\sqrt{2}}} (t^2 + t^2) \sqrt{2} dt + \int_0^{\frac{\pi}{4}} (\cos^2 t + \sin^2 t) dt + \int_0^1 (t^2 + 0^2) dt = \\ &= \frac{1}{3} + \frac{\pi}{4} + \frac{1}{3} = \frac{2}{3} + \frac{\pi}{4}. \end{aligned}$$

c) First of all let us explain some formulas in connection with the mass centre. Let $G(x_G, y_G)$ be the mass centre of the loaded arc $[\widehat{AB}]$. By definition, if we concentrate the entire mass of the arc in the point G , both static moments with respect to axes of this last obtained system is equal to static moments with respect to axes of the initial arc. If one

divide the arc into small pieces by the points $M_0 = A, M_1, \dots, M_n = B$ and if we consider the density function to be the same $f(P_i)$ on each arc $[\widehat{M_{i-1}M_i}]$, where $P_i(x_i, y_i)$ is a fixed point on this last arc, then the moment w.r.t. Ox -axis can be approximated by $\sum_{i=1}^n y_i f(P_i) \|\overrightarrow{M_{i-1}M_i}\|$, i.e. the moment is equal to $\int_{[\widehat{AB}]} y f(x, y) ds$. The moment w.r.t. Oy -axis will be $\int_{[\widehat{AB}]} x f(x, y) ds$. Let us use the remarks made above relative to the point G and write:

$$x_G \cdot \int_{[\widehat{AB}]} f(x, y) ds = \int_{[\widehat{AB}]} x f(x, y) ds$$

and

$$y_G \cdot \int_{[\widehat{AB}]} f(x, y) ds = \int_{[\widehat{AB}]} y f(x, y) ds.$$

Hence

$$(1.14) \quad x_G = \frac{\int_{[\widehat{AB}]} x f(x, y) ds}{\int_{[\widehat{AB}]} f(x, y) ds}, \quad y_G = \frac{\int_{[\widehat{AB}]} y f(x, y) ds}{\int_{[\widehat{AB}]} f(x, y) ds}.$$

Now we have to compute three line integrals. But the mass was just computed in b), mass = $\frac{\pi}{4}$. Let us compute the line integrals which appear at the numerators:

$$\begin{aligned} \int_{[\widehat{AB}]} x f(x, y) ds &= \int_{[\widehat{AB}]} x(x^2 + y^2) ds = \\ &= \int_0^{\frac{\pi}{4}} \cos t (\cos^2 t + \sin^2 t) dt = \sin t \Big|_0^{\frac{\pi}{4}} = \frac{1}{\sqrt{2}}. \\ \int_{[\widehat{AB}]} y f(x, y) ds &= \int_{[\widehat{AB}]} y(x^2 + y^2) ds = \\ &= \int_0^{\frac{\pi}{4}} \sin t (\cos^2 t + \sin^2 t) dt = -\cos t \Big|_0^{\frac{\pi}{4}} = 1 - \frac{1}{\sqrt{2}}. \end{aligned}$$

Hence

$$x_G = \frac{\frac{1}{\sqrt{2}}}{\frac{\pi}{4}} = \frac{2\sqrt{2}}{\pi}, \quad y_G = \frac{4 - 2\sqrt{2}}{\pi}.$$

d) Recall that the moment of inertia of a point $M(x, y)$ loaded with a mass m w.r.t. Oy -axis is equal to mx^2 (here x is the distance from M to Oy -axis). By a process of "globalization" i.e. of "integration" (explain it like in the case of the mass centre!) we get

$$I_{Oy} = \int_{[OB]} x^2 f ds = \int_0^{\frac{1}{\sqrt{2}}} t^2 (t^2 + t^2) \sqrt{2} dt = 2\sqrt{2} \frac{x^5}{5} \Big|_0^{\frac{1}{\sqrt{2}}} = \frac{1}{10}.$$

Let us put together all the formulas which give us the coordinates of mass centre of a space wire (I, \vec{r}, f) , where $\vec{r}(t) = (x(t), y(t), z(t))$. Let C be the support curve of this wire. Then,

$$(1.15) \quad x_G = \frac{\int_C x f ds}{\int_C f ds}; \quad y_G = \frac{\int_C y f ds}{\int_C f ds}; \quad z_G = \frac{\int_C z f ds}{\int_C f ds}.$$

Let now denote I_x, I_y, I_z the moments of inertia of the above wire w.r.t. Ox -axis, Oy -axis and Oz -axis respectively. Let I_O be the moment of inertia of the same wire w.r.t. the origin O . Then

$$(1.16) \quad I_x = \int_C (y^2 + z^2) f ds; \quad I_y = \int_C (x^2 + z^2) f ds;$$

$$I_z = \int_C (y^2 + x^2) f ds; \quad I_O = \int_C (x^2 + y^2 + z^2) f ds.$$

EXAMPLE 67. Let us consider the cylindrical helix

$$\Gamma : \begin{cases} x = a \cos t \\ y = a \sin t \\ z = bt \end{cases}, \quad t \in [0, 2\pi], \quad a, b > 0.$$

Here $ds = \sqrt{x'^2 + y'^2 + z'^2} dt = \sqrt{a^2 + b^2} dt$. Let us rotate Γ around Oz -axis and let us compute its moment of inertia. If nothing is mentioned on the density function, we tacitly consider it to be $f(x, y, z) = 1$. Thus one has

$$I_z = \int_C (y^2 + x^2) f ds = \int_0^{2\pi} a^2 \sqrt{a^2 + b^2} dt = 2\pi a^2 \sqrt{a^2 + b^2}.$$

Another application of the line integral of the first type appears when we want to compute the area of some cylindrical surface with the directrix arc $[\widehat{AB}]$ in the xOy -plane, the generating lines parallel to Oz -axis and limited by the xOy -plane and a surface $z = f(x, y) \geq 0$ (see Fig.7). Let $x = x(t), y = y(t)$ be a parametrization of the arc $[\widehat{AB}]$. We divide the arc $[\widehat{AB}]$ into n arcs $[\widehat{M_{i-1}M_i}]$. Let C_i be an arbitrary fixed point on the arc $[\widehat{M_{i-1}M_i}]$ and let C'_i the point on the surface $z = f(x, y)$ which is projecting in C_i . The area of the cylindrical surface $(M_{i-1}M_iM'_iM'_{i-1})$ with the directrix curve $[\widehat{M_{i-1}M_i}]$ and generating lines parallel to Oz -axis can be well approximated with the area of the space rectangle $[M_{i-1}M_iM''_iM''_{i-1}]$ with base the segment $[M_{i-1}M_i]$ and the height equal to the length of the segment $[C_iC'_i]$ (see Fig.7) This area is equal to $\| \overrightarrow{M_{i-1}M_i} \| \cdot f(C_i)$. Thus, the entire area can be well

approximated by the sum:

$$\sum_{i=1}^n \left\| \overrightarrow{M_{i-1}M_i} \right\| \cdot f(C_i).$$

Looking at the definition 17 and at the formula 1.5 we obtain that the area $\sigma(ABB'A')$ of the cylindrical surface bounded by $[\widehat{AB}]$, $[\widehat{A'B'}]$ and the segments $[AA']$, $[BB']$ (see Fig.7) can be computed by using the following formula:

$$(1.17) \quad \sigma(ABB'A') = \int_{[\widehat{AB}]} f ds.$$

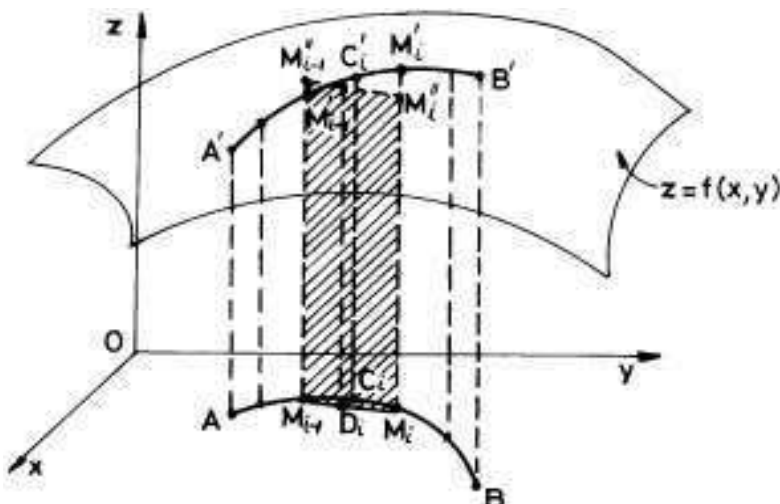

FIGURE 7

EXAMPLE 68. Let us find the area σ of the surface which are a part of the cylindrical surface with directrix curve the parabola $y = 2x^2$ in xOy -plane, generator lines parallel to Oz -axis, delimited by the xOy -plane and the plane $x + y + z = 10$ (see Fig.8). Since $z = 10 - x - y$, $f(x, y) = 10 - x - y$ in formula 1.17 and since $x = t, y = 2t^2, t \in [-1, 1]$ is a parametrization of the curve $[\widehat{AOD}]$, we get:

$$\sigma = \int_{[\widehat{AOD}]} (10 - x - y) ds = \int_{-1}^1 (10 - t - 2t^2) \sqrt{1 + 16t^2} dt.$$

Since the function $g(t) = t\sqrt{1 + 16t^2}$ is an odd function on the symmetric interval $[-1, 1]$ w.r.t. the origin O , one has that $\int_{-1}^1 t\sqrt{1 + 16t^2} dt =$

0. Hence it remains to compute the following definite integral

$$\int_{-1}^1 (10 - 2t^2)\sqrt{1 + 16t^2} dt = 2 \int_0^1 (10 - 2t^2)\sqrt{1 + 16t^2} dt,$$

etc.

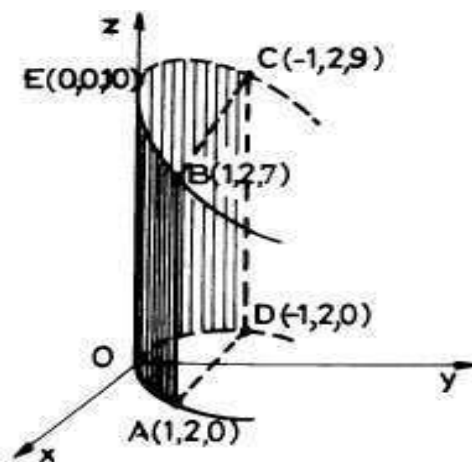

FIGURE 8

2. Line integrals of the second type.

Let M be a moving point on a segment $[a, b]$ from a to b in a field of forces $\vec{f}(x) = f(x)\vec{i}$, $x \in [a, b]$. We know (see example 42) that the work $W_{\vec{f}}[a, b]$ of M is equal to $\int_a^b f(x)dx$. If the field \vec{f} is a space field and if the point M is moving on an oriented space segment \overrightarrow{AB} then, in each position $P \in [AB]$ of M , the effective force which produces the work is the vector projection of \vec{f} along the vector \overrightarrow{AB} , i.e. the vector $\frac{\vec{f}(P) \cdot \overrightarrow{AB}}{\|\overrightarrow{AB}\|} \frac{\overrightarrow{AB}}{\|\overrightarrow{AB}\|}$, where $\vec{f}(P) \cdot \overrightarrow{AB}$ is the dot (scalar) product of the free vectors $\vec{f}(P)$ and \overrightarrow{AB} . Thus, if the length of the vector \overrightarrow{AB} is very small we can approximate the work of M on $[AB]$ by the dot product

$$(2.1) \quad \vec{f}(P) \cdot \overrightarrow{AB},$$

where P is a fixed point on $[AB]$.

DEFINITION 18. (*orientation of an arc*) Let us consider now a smooth curve \widehat{AB} with a parametrization $x = x(t)$, $y = y(t)$ and $z = z(t)$, $t \in [a, b]$ (see Fig.9). We say that the arc \widehat{AB} is oriented or

directly oriented if whenever $t_1 < t_2$ on $[a, b]$, then $\text{length}[\widehat{AM_1}] < \text{length}[\widehat{AM_2}]$, where $M_1(x(t_1), y(t_1), z(t_1))$ is the point on the curve which corresponds to $t_1 \in [a, b]$ and $M_2(x(t_2), y(t_2), z(t_2))$ is the point on the curve which corresponds to $t_2 \in [a, b]$. This means that whenever t goes from a to b , the corresponding moving point $M(x(t), y(t), z(t))$ goes from A to B on the curve, without turning back even for a very small "period of time". We always consider in our examples that a curve \widehat{AB} has two orientations: "the direct one", from A to B and "the inverse one", from B to A .

It can be proved (see any elementary course in Differential geometry) that any smooth curve Γ , realized as a deformation of an interval, can be oriented, i.e. it has two orientations. We divide the arc \widehat{AB} into n subarcs $\widehat{M_{i-1}M_i}$. The division $\{A = M_0, M_1, \dots, M_n = B\}$ is considered to be the image of a division $\Delta : a = t_0 < t_1 < \dots < t_n = b$ of the segment $[a, b]$ through the deformation $\vec{r}(t) = (x(t), y(t), z(t))$, $t \in [a, b]$ of the segment $[a, b]$ into the arc \widehat{AB} (see Fig.9).

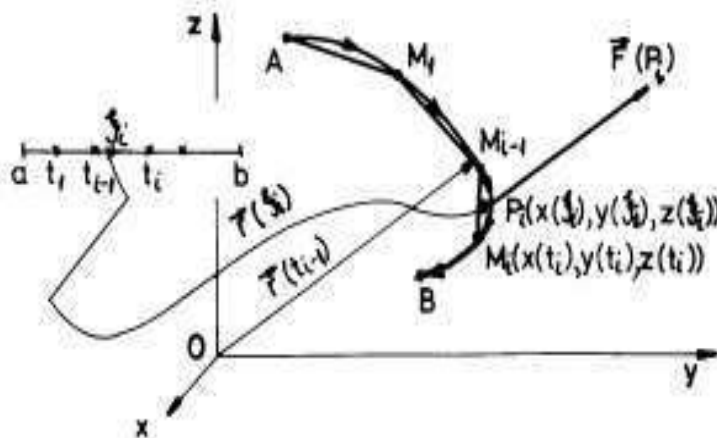

FIGURE 9

If the norm of the division Δ is very small, since the curve \widehat{AB} is smooth, the lengths of the subarcs $\widehat{M_{i-1}M_i}$ are very small. Thus we can approximate the work of a continuous field of forces $\vec{F}(x, y, z) = (P(x, y, z), Q(x, y, z), R(x, y, z))$ defined on the curve \widehat{AB} , along the

oriented arc $\widehat{[AB]}$, by the following sum:

$$(2.2) \quad S(\vec{F}, \Delta, \{\xi_i\}) = \sum_{i=1}^n \vec{F}(P_i) \cdot \overrightarrow{M_{i-1}M_i},$$

where P_i is a fixed point on the arc $\widehat{[M_{i-1}M_i]}$, i.e. $P_i(x(\xi_i), y(\xi_i), z(\xi_i))$, where $\{\xi_i\}$, $\xi_i \in [t_{i-1}, t_i]$, is a fixed set of marking points for the division Δ . Such a sum is called a *Riemann sum for \vec{F} , Δ and $\{\xi_i\}$* . Here the work $W_{\vec{F}}(\widehat{[M_{i-1}M_i]})$ of \vec{F} on $\widehat{[M_{i-1}M_i]}$ was approximated with $\vec{F}(P_i) \cdot \overrightarrow{M_{i-1}M_i}$.

DEFINITION 19. *With the above notation and definitions, for a general continuous and oriented arc of a curve $\Gamma = \vec{g}([a, b])$, where $\vec{g} : [a, b] \rightarrow \mathbb{R}^3$ (or \mathbb{R}^2), let us assume that there exists a real number S with the following property: if $\varepsilon > 0$ is a small positive real number, then there exists another small positive real number $\delta_\varepsilon > 0$ (depending on ε) such that if Δ is a division of $[a, b]$, one has that $|S - S(\vec{F}, \Delta, \{\xi_i\})| < \varepsilon$. This (unique) number S will be denoted by*

$\oint_{\Gamma} \vec{F} \cdot d\vec{r}$ or by $\oint_{\Gamma} Pdx + Qdy + Rdz$ and it is called the line integral of

the second type of \vec{F} or of the differential form $\omega = Pdx + Qdy + Rdz$ respectively. Here, formally, $d\vec{r} = (dx, dy, dz)$ and $\oint_{\Gamma} \vec{F} \cdot d\vec{r}$ will be

interpreted as "the work" of the field of forces \vec{F} along the oriented curve Γ (considered with the direct orientation), or "the circulation" of the field of forces \vec{F} along the oriented curve Γ if the curve Γ is "closed" ($\vec{r}(a) = \vec{r}(b)$). If we change the direct orientation with the inverse one (write Γ^-) the line integral will have a minus in front

of it, i.e. $\oint_{\Gamma^-} \vec{F} \cdot d\vec{r} \stackrel{\text{def}}{=} -\oint_{\Gamma} \vec{F} \cdot d\vec{r}$. Moreover, if $\Gamma = \cup_{i=1}^N \Gamma_i$ is

a finite union of nonoverlapping (they have in common at most one point) curves Γ_i , considered with the induced orientation of Γ , then

$\oint_{\Gamma} \vec{F} \cdot d\vec{r} = \sum_{i=1}^N \oint_{\Gamma_i} \vec{F} \cdot d\vec{r}$ (this is a consequence but I prefer to put

it in a definition!).

It is easy to see that the mapping $\vec{F} \rightarrow \oint_{\Gamma} \vec{F} \cdot d\vec{r}$ for a fixed curve Γ is a linear mapping. The basic problem is how to compute such a line integral $\oint_{\Gamma} \vec{F} \cdot d\vec{r}$. The following theorem will clarify this question.

THEOREM 65. *Let us consider again the above orientated smooth curve $\widehat{[AB]}$ with a parametrization $x = x(t)$, $y = y(t)$ and $z = z(t)$, $t \in [a, b]$, with a division Δ of the interval $[a, b]$, with its Riemann sum, etc. (see Fig.9 and all the starting discussion). Then*

$$(2.3) \quad \oint_{\widehat{[AB]}} \vec{F} \cdot d\vec{r} = \int_a^b \vec{F}(x(t), y(t), z(t)) \cdot \vec{r}'(t) dt,$$

or

$$(2.4) \quad \oint_{\widehat{[AB]}} \vec{F} \cdot d\vec{r} = \int_a^b [P(x(t), y(t), z(t))x'(t) + Q(x(t), y(t), z(t))y'(t) + R(x(t), y(t), z(t))z'(t)] dt,$$

$$\text{where } \vec{r}'(t) = (x(t), y(t), z(t)) = x(t)\vec{i} + y(t)\vec{j} + z(t)\vec{k}.$$

PROOF. First of all, in order to evaluate a Riemann sum of the type (2.2), let us compute the dot product $\vec{F}(P_i) \cdot \overrightarrow{M_{i-1}M_i}$.

$$\vec{F}(P_i) \cdot \overrightarrow{M_{i-1}M_i} \approx P(x(\xi_i), y(\xi_i), z(\xi_i)) [x(t_i) - x(t_{i-1})] +$$

$$(2.5) \quad + Q(x(\xi_i), y(\xi_i), z(\xi_i)) [y(t_i) - y(t_{i-1})] +$$

$$(2.6) \quad + R(x(\xi_i), y(\xi_i), z(\xi_i)) [z(t_i) - z(t_{i-1})].$$

Let us now apply Lagrange formula for functions $x(t)$, $y(t)$ and $z(t)$ defined on the interval $[t_{i-1}, t_i]$:

$$x(t_i) - x(t_{i-1}) = x'(c_i)(t_i - t_{i-1}),$$

where $c_i \in [t_{i-1}, t_i]$,

$$y(t_i) - y(t_{i-1}) = y'(d_i)(t_i - t_{i-1}),$$

where $d_i \in [t_{i-1}, t_i]$ and

$$z(t_i) - z(t_{i-1}) = z'(e_i)(t_i - t_{i-1}),$$

where $e_i \in [t_{i-1}, t_i]$. Since the norm $\|\Delta\|$ is very small, i.e. the lengths of intervals $[t_{i-1}, t_i]$ are small enough and since the functions $x'(t)$, $y'(t)$, $z'(t)$ are continuous (the curve is of class C^1 being smooth), we can well approximate $x'(c_i)$, $y'(d_i)$ and $z'(e_i)$ with $x'(\xi_i)$, $y'(\xi_i)$ and with $z'(\xi_i)$ respectively (c_i , d_i and e_i are very close to ξ_i and the previous functions are continuous!). Thus formula (2.5) can be rewritten as

$$\begin{aligned} & \vec{F}(P_i) \cdot \overline{M_{i-1}M_i} = \\ & = [P(x(\xi_i), y(\xi_i), z(\xi_i))x'(\xi_i) + Q(x(\xi_i), y(\xi_i), z(\xi_i))y'(\xi_i)](t_i - t_{i-1}) + \\ & \quad + R(x(\xi_i), y(\xi_i), z(\xi_i))z'(\xi_i)(t_i - t_{i-1}). \end{aligned}$$

Thus, the Riemann sum $S(\vec{F}, \Delta, \{\xi_i\}) = \sum_{i=1}^n \vec{F}(P_i) \cdot \overline{M_{i-1}M_i}$ can be approximated with

$$\begin{aligned} & \sum_{i=1}^n [P(x(\xi_i), y(\xi_i), z(\xi_i))x'(\xi_i) + Q(x(\xi_i), y(\xi_i), z(\xi_i))y'(\xi_i) + \\ & \quad + R(x(\xi_i), y(\xi_i), z(\xi_i))z'(\xi_i)](t_i - t_{i-1}), \end{aligned}$$

which is nothing else than a Riemann sum for the simple Riemann integral

$$\begin{aligned} & \int_a^b [P(x(t), y(t), z(t))x'(t) + Q(x(t), y(t), z(t))y'(t) + \\ & \quad + R(x(t), y(t), z(t))z'(t)] dt. \end{aligned}$$

Taking limits as $\|\Delta\| \rightarrow 0$, we get formula (2.4).

Since $d\vec{r} = (x'(t), y'(t), z'(t))dt$, formula (2.3) is an immediate consequence of formula (2.4). \square

This last theorem says that in order to compute a line integral of the second type, we must find a suitable (not so complicated!) parameterization of the arc $\widehat{[AB]}$, then we simply apply formula (2.4) to reduce the computation to a calculation of a Riemann definite integral. If the curve and the field of forces are all in the same plane xOy , we put $z(t) = 0$ and $R(x, y, z) = 0$ in formula (2.4), i.e. we get an easier formula:

$$\begin{aligned} & \oint_{\widehat{[AB]}} \vec{F} \cdot d\vec{r} = \int_a^b \vec{F}(x(t), y(t)) \cdot \vec{r}'(t) dt = \\ & = \int_a^b [P(x(t), y(t))x'(t) + Q(x(t), y(t))y'(t)] dt. \end{aligned}$$

EXAMPLE 69. Let $\vec{F}(x, y) = x^2 \vec{i} + xy \vec{j}$ be a plane field of forces (or, equivalently, let $\omega = x^2 dx + xy dy$ be a plane differential form of order I) and let Γ be the marked with arrows oriented curve in Fig.10 (the arrows indicate the orientation!)

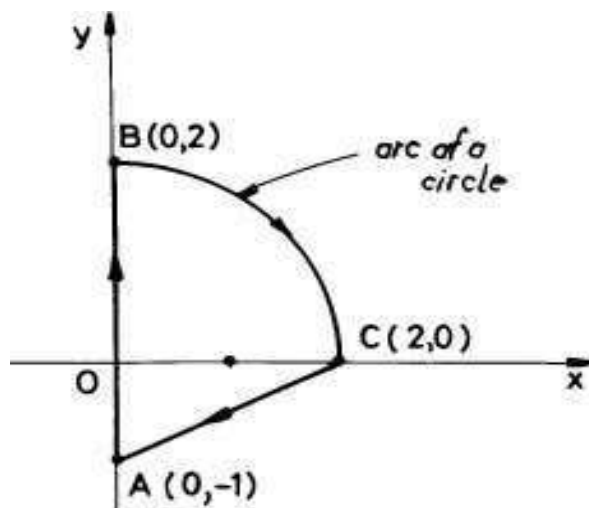

FIGURE 10

- a) Find the work on the arc of the circle $[\widehat{BC}]$; b) Compute $\oint_{[\widehat{AB}]} \vec{F} \cdot d\vec{r}$; c) Compute $\oint_{[\widehat{CA}]} Pdx + Qdy$;

d) Compute the circulation of the field \vec{F} along the closed oriented (like in Fig.10) curve $[CABC]$. Since our last curve is not smooth (it has "corners!") we must decompose it into 3 smooth nonoverlapping curves: $[\widehat{CA}]$, $[\widehat{AB}]$ and $[\widehat{BC}]$ respectively and then to write (see definition 19):

$$(2.7) \quad \oint_{[CABC]} \vec{F} \cdot d\vec{r} = \oint_{[\widehat{CA}]} \vec{F} \cdot d\vec{r} + \oint_{[\widehat{AB}]} \vec{F} \cdot d\vec{r} + \oint_{[\widehat{BC}]} \vec{F} \cdot d\vec{r}.$$

Let us find 3 separate parametrizations for the component curves $[\widehat{CA}]$, $[\widehat{AB}]$ and $[\widehat{BC}]$.

$$[\widehat{CA}] : \begin{cases} x = 2 + (-2)t \\ y = 0 + (-1)t \end{cases}, t \in [0, 1];$$

$$\widehat{[AB]} : \begin{cases} x = 0 \\ y = t \end{cases}, t \in [-1, 2];$$

$$\widehat{[BC]} : \begin{cases} x = 2 \cos t \\ y = 2 \sin t \end{cases}, t \in [0, \frac{\pi}{2}]^-,$$

i.e. t goes from $\frac{\pi}{2}$ to 0. Now we are ready to compute everything. a)

The work on the arc $\widehat{[BC]}$ can be find as follows:

$$\begin{aligned} \oint_{\widehat{[BC]}} \vec{F} \cdot d\vec{r} &= \oint_{\widehat{[BC]}} Pdx + Qdy = \\ &= - \int_0^{\frac{\pi}{2}} [(2 \cos t)^2 (2 \cos t)' + (2 \cos t)(2 \sin t)(2 \sin t)'] dt = \\ &= -8 \int_0^{\frac{\pi}{2}} [-\cos^2 t \sin t + \cos^2 t \sin t] dt = 0. \end{aligned}$$

b)

$$\oint_{\widehat{[AB]}} \vec{F} \cdot d\vec{r} = \int_{-1}^2 [0^2 \cdot 0 + 0 \cdot t dt] = 0.$$

c)

$$\oint_{\widehat{[CA]}} Pdx + Qdy = \int_0^1 [(2 - 2t)^2(-2) + (2 - 2t)(-t)(-1)] dt = -\frac{7}{3}.$$

d) The work or the circulation on $[CABC]$ is the sum of the results just obtained in a), b) and c), i.e. $-\frac{7}{3}$.

Here is a nice application to Physics.

THEOREM 66. (the gain principle) Let $W = \int_{\Gamma} \vec{F} \cdot d\vec{r}$ be the work of a moving point M of mass m in a continuous field of forces, along an oriented smooth curve Γ , realized as a deformation $\vec{r}(t) = (x(t), y(t), z(t))$ of the interval $[a, b]$. Then $W = T(B) - T(A)$, where $T = \frac{m}{2} |\vec{v}|^2$ is the kinetic energy of the moving system, $\vec{v} = \vec{r}'$ is the velocity vector and A, B are the end points of the trajectory Γ . Here the difference $T(B) - T(A)$ is called "the gain in kinetic energy". Thus, the gain principle in Physics says that the work done by a moving point on a trajectory $\widehat{[AB]}$ is equal to the gain in kinetic energy of the moving point.

PROOF. Since the second law of dynamics says that $\vec{F} = m\vec{v}'$, we can apply formula (2.3) and successively write:

$$\begin{aligned} W &= \oint_{\Gamma} \vec{F} \cdot d\vec{r} = \int_a^b \vec{F}(\vec{r}(t)) \cdot \vec{v}(t) dt = m \int_a^b \vec{v}'(t) \cdot \vec{v}(t) dt = \\ &= m \int_a^b \left(\frac{\vec{v} \cdot \vec{v}}{2} \right)' dt = \frac{m}{2} |\vec{v}|^2 \Big|_a^b = T(B) - T(A). \end{aligned}$$

□

REMARK 20. *Maybe somebody asks what happens with a line integral $\oint_{\Gamma} \vec{F} \cdot d\vec{r}$ if we change the parametrization of the given curve Γ , i.e. if the parametric path \vec{r} changes with an equivalent one \vec{r}^* . To preserve the initial orientation we must assume that the change of variables $\Phi : [a^*, b^*] \rightarrow [a, b]$ is an increasing one, i.e. $\Phi'(t) > 0$. Then, $\vec{r}^*(t^*) = \vec{r}(\Phi(t^*))$ and $dt^* = \frac{dt^*}{dt} dt$. Thus,*

$$\begin{aligned} \oint_{\Gamma} \vec{F}(\vec{r}^*) \cdot d\vec{r}^* &= \int_{a^*}^{b^*} \left[\vec{F}(\vec{r}^*) \cdot \frac{d\vec{r}^*}{dt^*} \right] dt^* = \\ &= \int_{a^*}^{b^*} \left[\vec{F}(\vec{r}(\Phi(t^*))) \cdot \frac{d\vec{r}}{dt} \frac{dt}{dt^*} \right] dt^* = \\ &= \int_a^b \vec{F}(\vec{r}(t)) \vec{r}'(t) dt = \oint_{\Gamma} \vec{F} \cdot d\vec{r}. \end{aligned}$$

Thus the value of the line integral does not change. It depends only on the curve itself and not on its particular parametrization.

3. Independence on path. Conservative fields

Looking at formula (2.4) we see that the line integral $\oint_{\widehat{[AB]}} \vec{F} \cdot d\vec{r}$

depends on the curve $\Gamma = \widehat{[AB]}$ which connects the points A and B and on the field \vec{F} . It does not depend on the parametrization itself, because the change of variable formula in the usual definite integral gives us that the line integral does not change if we change \vec{r} with an equivalent path \vec{r}' (here \vec{r} and \vec{r}' both connect A and B).

DEFINITION 20. *Let D be a space (or plane) domain and let $\vec{F} : D \rightarrow \mathbb{R}^3$ (or \mathbb{R}^2) be a continuous field. We say that the integral $\oint \vec{F} \cdot d\vec{r}$ (this is only a symbol here!) is independent on path if for any two*

points A and B of D and for any (piecewise) smooth path $\gamma \subset D$, which connects A and B , the line integral of the second type $\int_{\gamma} \vec{F} \cdot d\vec{r}$ does not depend on the curve γ itself but only on the end points A and B of it. This means that if Γ is another path which connect A and B one has that $\int_{\gamma} \vec{F} \cdot d\vec{r} = \int_{\Gamma} \vec{F} \cdot d\vec{r}$.

It is clear enough that this property characterizes the field \vec{F} defined on D . We shall define a class of fields which has the above property, namely that the integral $\int \vec{F} \cdot d\vec{r}$ is independent on path.

DEFINITION 21. A field $\vec{F} : D \rightarrow \mathbb{R}^3$ is said to be a conservative (potential) field if there exists a scalar function $U : D \rightarrow \mathbb{R}$ of class C^1 such that $\text{grad } U = \vec{F}$, i.e. if $\vec{F}(x, y, z) = P(x, y, z)\vec{i} + Q(x, y, z)\vec{j} + R(x, y, z)\vec{k}$ then $\frac{\partial U}{\partial x} = P$, $\frac{\partial U}{\partial y} = Q$ and $\frac{\partial U}{\partial z} = R$. It is clear that \vec{F} is conservative if and only if the differential form $\omega = Pdx + Qdy + Rdz$ has a primitive $U(x, y, z)$, i.e. a scalar function $U(x, y, z)$ such that $dU = \omega$. We also say in this case that ω is exact or closed on D . The function U is called the potential function or the primitive of \vec{F} and the function $-U$ is called the potential energy of \vec{F} .

For instance, the central field $\vec{F} = c\vec{r}$ ("draw" it for $c > 0$ and for $c < 0$), where $\vec{r} = x\vec{i} + y\vec{j} + z\vec{k}$ is the position vector of the point $M(x, y, z)$ and c is a real constant, is a conservative field because $U(x, y, z) = \frac{x^2}{2} + \frac{y^2}{2} + \frac{z^2}{2}$ is a "potential" function for \vec{F} . If we add an arbitrary constant K to this $U(x, y, z)$ we also get a potential function for \vec{F} . It is clear enough that not all fields are conservative. For instance, the plane field $\vec{F}(x, y) = 3x^2\vec{i} + xy\vec{j}$ is not a conservative field on any domain of \mathbb{R}^2 . Indeed, suppose that \vec{F} is conservative on a small disc $B(\mathbf{a}, \rho)$, with $\rho > 0$. Then there is a potential function $U(x, y)$ such that

$$(3.1) \quad \begin{cases} \frac{\partial U}{\partial x} = 3x^2, \\ \frac{\partial U}{\partial y} = xy \end{cases} .$$

Let us integrate (find a primitive) the first equality w.r.t. x :

$$\int \frac{\partial U}{\partial x} dx = U(x, y) + K(y) = x^3 + H(y),$$

where $K(y)$ and $H(y)$ are constant w.r.t. x but, in general, functions of y . Let us put $C(y) = H(y) - K(y)$. Thus $U(x, y) = x^3 + C(y)$. With

this expression of U , let us come in the second equality of (3.1) and find

$$C'(y) = xy,$$

which is not possible, because $C'(y)$ cannot be a function of x . Thus, our assumption is false, i.e. $\vec{F}(x, y) = 3x^2\vec{i} + xy\vec{j}$ cannot be a conservative field.

Such conservative fields appears in nature, in mechanics, astronomy, material sciences, etc. For instance, the gravitational field $\vec{G}(x, y, z) = -mg\vec{k}$, where m is a constant mass at any point $M(x, y, z)$ and $g = 9.8m/s^2$ is the known gravitational acceleration constant (see Fig.11), is a conservative field.

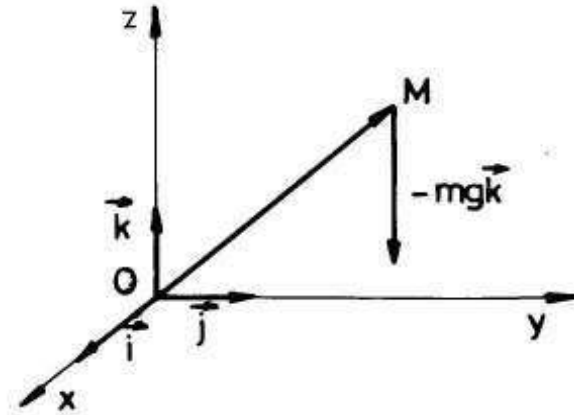

FIGURE 11

Indeed, let us find the general form of all the potential functions $U(x, y, z)$ of \vec{G} :

$$\begin{cases} \frac{\partial U}{\partial x} = 0 \\ \frac{\partial U}{\partial y} = 0 \\ \frac{\partial U}{\partial z} = -mg \end{cases} .$$

Let us integrate the last equation w.r.t. z and put the constants which appear only once:

$$U(x, y, z) = -mgz + K(x, y),$$

where $K(x, y)$ is a constant w.r.t. z but, in general, it can depend on x and y because, in general, U may depend on x and y . Let us introduce

this last expression of U in the second equality and find:

$$\frac{\partial K}{\partial y} = 0.$$

Thus K is also a constant function w.r.t. y . Hence $K(x, y) = K(x)$ only. So that $U(x, y, z) = -mgz + K(x)$ and, finally, let us put this last expression of U in the first equality and find:

$$K'(x) = 0,$$

so that K is constant w.r.t. x, y and z respectively. Now, the general form of a primitive function for \vec{G} is

$$U(x, y, z) = -mgz + K.$$

This means that the potential energy of the gravitational field is of the form $-U = mgz - K$. Since for $z = 0$ (at the horizontal plane of the earth) the potential energy is equal to zero, K must be zero and we refound a known formula from high school: the potential energy $= mgh$, where h is the height at which the mass m is.

A strange property of such conservative fields is that the work of them does not depend on path, or that the circulation of them on a "closed" curve ($\vec{r}(a) = \vec{r}(b)$) is always equal to zero. Here is the mathematically stated result.

THEOREM 67. (*Leibniz-Newton formula for line integrals*) Let $\vec{F} : D \rightarrow \mathbb{R}^3$ be a continuous conservative (potential) field and let Γ be an arc of an oriented smooth curve in D with its end points A and B . Let $\vec{r}(t) = (x(t), y(t), z(t))$, $t \in [a, b]$ be a parametrization of Γ . Then

$$(3.2) \quad \int_{\Gamma} \vec{F} \cdot d\vec{r} = U(B) - U(A) = U(x(b), y(b), z(b)) - U(x(a), y(a), z(a)),$$

where $U(x, y, z)$ is a potential function (a primitive) of \vec{F} .

b) In particular, $\int_{\Gamma} \vec{F} \cdot d\vec{r}$ does not depend on the curve Γ which connect the points A and B , i.e. the integral $\int_{\Gamma} \vec{F} \cdot d\vec{r}$ does not depend on path in D .

c) Another consequence is that two primitives U and V of \vec{F} on D differ one to each other by a constant only.

d) For any "closed" curve δ ($\vec{r}(b) = \vec{r}(a)$) of D one has that $\oint_{\delta} \vec{F} \cdot d\vec{r} = 0$. Conversely, if for any smooth closed curve δ of D we have that $\oint_{\delta} \vec{F} \cdot d\vec{r} = 0$, then $\int_{\delta} \vec{F} \cdot d\vec{r}$ does not depend on path in D .

PROOF. a) Let $U(x, y, z)$ be a primitive of

$$\vec{F}(x, y, z) = P(x, y, z) \vec{i} + Q(x, y, z) \vec{j} + R(x, y, z) \vec{k}.$$

Then $\frac{\partial U}{\partial x} = P$, $\frac{\partial U}{\partial y} = Q$ and $\frac{\partial U}{\partial z} = R$. Let us consider the composed function $g(t) = U(x(t), y(t), z(t))$, $t \in [a, b]$. By using the chain rule (derivative of U along the curve Γ , see [Pö], Th.68), let us compute its derivative:

$$\begin{aligned} g'(t) &= \frac{\partial U}{\partial x}(x(t), y(t), z(t))x'(t) + \frac{\partial U}{\partial y}(x(t), y(t), z(t))y'(t) + \\ &+ \frac{\partial U}{\partial z}(x(t), y(t), z(t))z'(t) = P(x(t), y(t), z(t))x'(t) + \\ &+ Q(x(t), y(t), z(t))y'(t) + R(x(t), y(t), z(t))z'(t). \end{aligned}$$

Let us use the basic formula (2.4) and write:

$$\begin{aligned} \int_{\Gamma} \vec{F} \cdot d\vec{r} &= \int_a^b [P(x(t), y(t), z(t))x'(t) + Q(x(t), y(t), z(t))y'(t) + \\ &+ R(x(t), y(t), z(t))z'(t)] dt = \\ &= \int_a^b g'(t) dt = g(b) - g(a) = U(x(b), y(b), z(b)) - U(x(a), y(a), z(a)) = \\ &= U(B) - U(A). \end{aligned}$$

b) It is clear from a).

c) Let U, V be two primitives of \vec{F} on D and let $M_0(x_0, y_0, z_0)$ be a fixed point of D . Let now $M(x, y, z)$ be another (variable) point of D . Since D is connected (D is a domain, i.e. open and connected) let us take a smooth arc γ in D which connect M_0 and M , oriented "from M_0 to M ". We apply now formula (3.2) for both primitives U and V and find:

$$\int_{\Gamma} \vec{F} \cdot d\vec{r} = U(M) - U(M_0) = V(M) - V(M_0),$$

or

$$U(M) - V(M) = U(M_0) - V(M_0) = K,$$

a constant, so that $U(x, y, z) = V(x, y, z) + K$ and our theorem is completely proved.

d) In formula (3.2) we simply put $x(a) = x(b)$, $y(a) = y(b)$ and $z(a) = z(b)$, etc. Assume now that on any "closed" smooth curve δ one has that $\oint_{\delta} \vec{F} \cdot d\vec{r} = 0$. Take now two points T and W in D and two distinct smooth oriented curves Γ_1, Γ_2 which connect T and W . Then the curve $\delta = \Gamma_1 \cup \Gamma_2^{-}$ is "closed", so that $\oint_{\Gamma_1 \cup \Gamma_2^{-}} \vec{F} \cdot d\vec{r} = 0$. But

$$\oint_{\Gamma_1 \cup \Gamma_2^{-}} \vec{F} \cdot d\vec{r} = \oint_{\Gamma_1} \vec{F} \cdot d\vec{r} - \oint_{\Gamma_2} \vec{F} \cdot d\vec{r} = 0,$$

i.e. $\oint_{\Gamma_1} \vec{F} \cdot d\vec{r} = \oint_{\Gamma_2} \vec{F} \cdot d\vec{r}$ and our integral $\oint \vec{F} \cdot d\vec{r}$ does not depend on path. \square

Now we are ready to make many applications. One of these is related to a large simplification of computations in a line integral of the second type.

EXAMPLE 70. Let γ be the "closed" oriented (as arrows indicate) curve

$[OAmBnCO]$ of Fig.12.

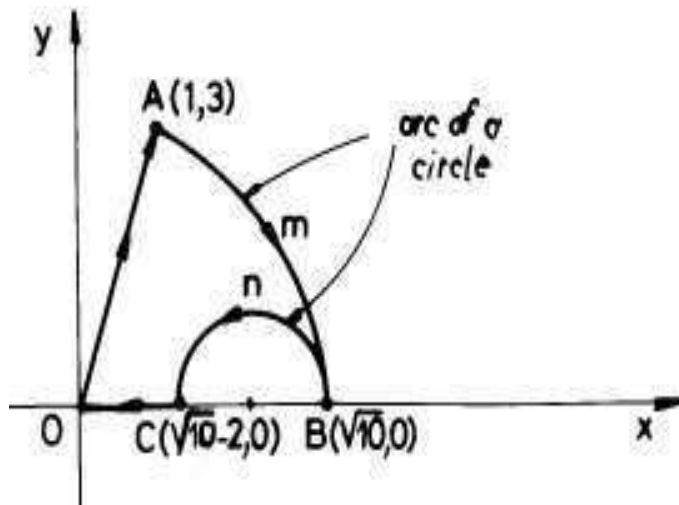

FIGURE 12

Let us compute the circulation (or the work) of the plane field $\vec{F}(x,y) = 2xy\vec{i} + x^2\vec{j}$ along the curve γ . Because the curve is a union of 4 smooth distinct curves, we ought to find a parametrization for each of them, compute 4 line integrals and then add the four obtained numbers (see example 69). All of this may be very boring and

tiresome. The best method is to check first of all if the field is conservative or not. If we were lucky that the field to be conservative, then the line integrals does not depend on path and we can choose a very easy path which connect the starting and the end points of the arc. In our case the arc is closed, so that the integral is zero. Let us check now if our field is conservative or not. For this, let us try to find $U(x, y)$ such that

$$\frac{\partial U}{\partial x} = 2xy, \text{ and } \frac{\partial U}{\partial y} = x^2.$$

We integrate the first equality w.r.t. x and find: $U = x^2y + K(y)$. Let us put this expression of U in the second equation and find: $x^2 + K'(y) = x^2$. Thus, $K'(y) = 0$ and $K(y)$ is a constant K . Hence $U(x, y) = x^2y + K$, where K is an arbitrary constant. Therefore our field is conservative and, as a consequence, the given line integral is zero (see theorem 67).

But, how to test if a field is conservative or not without direct checking if a potential (primitive) function exists, like we did above? We begin with the following remark.

THEOREM 68. Let $\vec{F} : D \rightarrow \mathbb{R}^3$,
 $\vec{F}(x, y, z) = (P(x, y, z), Q(x, y, z), R(x, y, z))$ be a conservative field of class C^1 on a space domain D . Then $\text{curl } \vec{F} = \vec{0}$, i.e. the field \vec{F} is an irrotational field. If $\vec{F} : D \rightarrow \mathbb{R}^2$, $\vec{F}(x, y) = (P(x, y), Q(x, y))$, is a plane conservative field of class C^1 on a plane domain D , then $\frac{\partial Q}{\partial x} = \frac{\partial P}{\partial y}$ on D .

PROOF. Let $U(x, y, z)$ be a primitive function for the conservative field

$$\vec{F}(x, y, z) = (P(x, y, z), Q(x, y, z), R(x, y, z)).$$

Then $\frac{\partial U}{\partial x} = P$, $\frac{\partial U}{\partial y} = Q$ and $\frac{\partial U}{\partial z} = R$. We know that

$$\text{curl } \vec{F} = \nabla \times \vec{F} = \left(\frac{\partial R}{\partial y} - \frac{\partial Q}{\partial z} \right) \vec{i} - \left(\frac{\partial R}{\partial x} - \frac{\partial P}{\partial z} \right) \vec{j} + \left(\frac{\partial Q}{\partial x} - \frac{\partial P}{\partial y} \right) \vec{k}.$$

If here instead of P, Q, R we put $\frac{\partial U}{\partial x}, \frac{\partial U}{\partial y}$ and $\frac{\partial U}{\partial z}$ respectively, we get $\frac{\partial R}{\partial y} - \frac{\partial Q}{\partial z} = \frac{\partial^2 U}{\partial y \partial z} - \frac{\partial^2 U}{\partial z \partial y} = 0$ because U is a function of class C^2 (since P, Q, R are functions of class C^1) and we can apply Schwarz' theorem (see theorem 71, [Po]). Similarly we can easily show that $\frac{\partial R}{\partial x} - \frac{\partial P}{\partial z} = 0$ and $\frac{\partial Q}{\partial x} - \frac{\partial P}{\partial y} = 0$, i.e. $\text{curl } \vec{F} = \vec{0}$. In the plane field situation, we put instead $Q, \frac{\partial U}{\partial y}$ and instead of $P, \frac{\partial U}{\partial x}$, so that $\frac{\partial Q}{\partial x} = \frac{\partial^2 U}{\partial x \partial y}$ and $\frac{\partial P}{\partial y} = \frac{\partial^2 U}{\partial y \partial x}$. Since u is of class C^2 , $\frac{\partial^2 U}{\partial x \partial y} = \frac{\partial^2 U}{\partial y \partial x}$, i.e. $\frac{\partial Q}{\partial x} = \frac{\partial P}{\partial y}$. \square

We say that a plane domain D is *simple connected* if any continuous "closed" curve $\gamma \subset D$ can be continuously contracted up to a point in D . We say that a space domain D is *simple connected* if any continuous "closed" surface (the image of a sphere through a continuous deformation in \mathbb{R}^3) Σ can be continuously contracted up to a point in D . Practically, if D has no "hole" it is simple connected. For instance, any disc in \mathbb{R}^2 is simple connected but $\mathbb{R}^2 \setminus \{(0,0)\}$ is not simple connected because it has a hole, the origin of the axes.

REMARK 21. *If D is a simple connected domain then theorem 68 has a reciprocal. Namely, if $\text{curl } \vec{F} = \vec{0}$ or $\frac{\partial Q}{\partial x} = \frac{\partial P}{\partial y}$ in the plane field case, then \vec{F} is a conservative field. We shall give an elegant proof of this last result in the next chapter (for a plane domain, see Green's formula) and, in another chapter (for a space domain), as an application to Stokes' formula. We also sketch a proof for plane domains in remark 26. The condition that D be simple connected is essential as follows from the next example. Let $D = \mathbb{R}^2 \setminus \{(0,0)\}$ be a not simple connected domain and let $\vec{F} = (P, Q)$, where $P = -\frac{y}{x^2+y^2}$ and $Q = \frac{x}{x^2+y^2}$. It is easy to see that $\frac{\partial Q}{\partial x} = \frac{y^2-x^2}{(x^2+y^2)^2} = \frac{\partial P}{\partial y}$ but*

$$\oint_{x^2+y^2=1} -\frac{y}{x^2+y^2}dx + \frac{x}{x^2+y^2}dy = \int_0^{2\pi} [\sin^2 t + \cos^2 t]dt = 2\pi \neq 0.$$

Hence \vec{F} cannot be conservative on D (see theorem 67 d)).

This last remark is very useful in practice. Let us compute $\int_{\gamma} xdx + ydy + zdz$, where γ is the oriented path from Fig.13.

Since $\vec{F} = (x, y, z)$ is irrotational, i.e. $\text{curl } \vec{F} = \vec{0}$, the integral does not depend on path and its value is $U(1, 5, 3) - U(0, 0, 0)$, where U is a primitive of \vec{F} . We know that such a primitive exists from the last remark (D is the entire \mathbb{R}^3 so it is simple connected). Thus we can directly compute it by integrating the system

$$\begin{cases} \frac{\partial U}{\partial x} = x \\ \frac{\partial U}{\partial y} = y \\ \frac{\partial U}{\partial z} = z \end{cases} .$$

It is easy to see that $\frac{x^2+y^2+z^2}{2} + K$, where K is a constant, is the general solution of this system (use the same idea like in the case of the

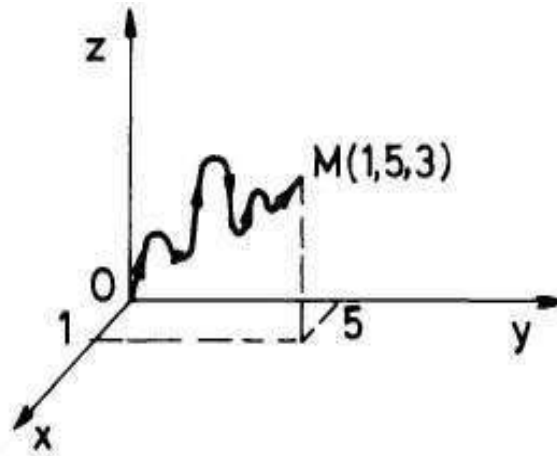

FIGURE 13

gravitational field). Take $U(x, y, z) = \frac{x^2+y^2+z^2}{2}$ and compute $U(1, 5, 3) - U(0, 0, 0) = \frac{35}{2}$.

When a line integral of the second type $\oint \vec{F} \cdot d\vec{r}$ does not depend on path on a domain D , then instead of writing $\oint_{[\widehat{AB}]} \vec{F} \cdot d\vec{r}$, where $[\widehat{AB}]$ is a path in D which connects two points A and B of D , we simply write $\int_A^B \vec{F} \cdot d\vec{r}$. To compute such an integral we can use a primitive of \vec{F} or we can use any arc of a piecewise smooth curve γ included in D which connect A and B in this order. Namely, we write $\int_A^B \vec{F} \cdot d\vec{r} = U(B) - U(A)$ or $\int_A^B \vec{F} \cdot d\vec{r} = \int_{\gamma} \vec{F} \cdot d\vec{r}$. The usual choice for γ is a segment of a line or a finite union of segments of lines, eventually parallel with the coordinate axes. For instance,

$$\begin{aligned} \int_{(1,-1,2)}^{(3,0,-2)} xdx + ydy + zdz &= \int_{(1,-1,2)}^{(3,-1,2)} xdx + ydy + zdz + \\ &+ \int_{(3,-1,2)}^{(3,0,2)} xdx + ydy + zdz + \int_{(3,0,2)}^{(3,0,-2)} xdx + ydy + zdz = \end{aligned}$$

$$= \int_1^3 x dx + \int_{-1}^0 y dy + \int_2^{-2} z dz = \frac{x^2}{2} \Big|_1^3 + \frac{y^2}{2} \Big|_{-1}^0 + \frac{z^2}{2} \Big|_2^{-2} = 4 - \frac{1}{2} + 0 = \frac{7}{2}.$$

REMARK 22. *The idea coming from this last example can be generalized in order to construct a primitive for a conservative continuous field $\vec{F} = (P, Q, R)$ on a domain D . In order to prove that a field \vec{F} is conservative on a simple connected domain, the best is to use the criterion just described in remark 21 namely, to verify if $\text{curl } \vec{F} = \vec{0}$ (in the space case), or to verify that $\frac{\partial Q}{\partial x} = \frac{\partial P}{\partial y}$ (in the plane case). Let us describe an effective construction for such a primitive $U(x, y)$ in the plane case (for the space case the description is more tiresome). First of all let us choose a fixed point $M_0(x_0, y_0)$ in D . The primitive U we are going to construct will depend on the choice of this fixed point. We just know that all the primitives of a given field differ one to each other by a constant. Thus, such a primitive is completely determined by its value at a point. In our case we shall determine the primitive $U(x, y)$ with the property: $U(x_0, y_0) = 0$. Take now another point $M(c, d)$ of D and try to define the value of U at this "moving" point M . Let $[M_0M_1M_2\dots M_{2n-1}M_{2n}]$, $M_{2n} = M$, be a polygonal line in D , which connect M_0 with M , such that the couples of segments*

$$([M_0M_1], [M_1M_2]), ([M_2M_3], [M_3M_4]), \dots, ([M_{2n-2}M_{2n-1}], [M_{2n-1}M_{2n}])$$

has the following property: in each couple $([M_{2j-2}M_{2j-1}], [M_{2j-1}M_{2j}])$, $j = 1, 2, \dots, n$, the first segment $[M_{2j-2}M_{2j-1}]$ is parallel to Ox -axis and the second $[M_{2j-1}M_{2j}]$ is parallel to Oy -axis. We start with the value of U at M_0 and shall find the value of it at M_2 (we operate with the first couple). Then we use the value of U at M_2 and, by the same procedure, we find the value of U at M_4 and so on up to we succeed to find the value of U at $M_{2n} = M$. Hence we reduced everything in describing the procedure only for the first couple $([M_0M_1], [M_1M_2])$. More exactly, it is sufficient to construct $U(x, y)$ in a small open disc $B(M_0, r) \subset D$, $r > 0$, with centre at M_0 and radius r . Let $P(s, u) \in B(M_0, r)$ and let the couple of segments $([M_0P_1], [P_1P])$ such that $P_1(s, y_0)$, i.e. the segment $[M_0P_1]$ is parallel to Ox -axis and $[P_1P]$ is parallel to Oy -axis. It is clear that the polygonal line $[M_0P_1P]$ is contained in the disc $B(M_0, r)$, i.e. it is contained in D too. Let us define now:

$$U(s, u) = \oint_{M_0}^P P dx + Q dy = \oint_{[M_0P_1]} P dx + Q dy + \oint_{[P_1P]} P dx + Q dy.$$

or

$$(3.3) \quad U(s, u) = \int_{x_0}^s P(x, y_0) dx + \int_{y_0}^u Q(s, y) dy.$$

We see that here we have integrals with parameters. Let us use the conservativeness hypothesis of $\vec{F} = (P, Q)$ which implies $\frac{\partial Q}{\partial x} = \frac{\partial P}{\partial y}$ and the Leibniz formula (1.9), Ch.4, to compute (the existence is also assured!) $\frac{\partial U}{\partial s}(s, u)$ and $\frac{\partial U}{\partial u}(s, u)$:

$$\begin{aligned} \frac{\partial U}{\partial s}(s, u) &= P(s, y_0) + \int_{y_0}^u \frac{\partial Q}{\partial s}(s, y) dy = P(s, y_0) + \int_{y_0}^u \frac{\partial P}{\partial y}(s, y) dy = \\ &P(s, y_0) + P(s, u) - P(s, y_0) = P(s, u). \end{aligned}$$

Now,

$$\frac{\partial U}{\partial u}(s, u) = Q(s, u).$$

Hence U is a primitive of \vec{F} on that ball. In particular we have the value of U at the point M_2 . We now go on with M_2 instead of M_0 and find the value of U at M_4 , etc., up to M_{2n} . To be easier, we can choose from the beginning a finite set of overlapping balls inside D , the first containing M_0 and the last containing $M = M_{2n}$. Then choose M_1 in the intersection of the first and of the second ball, M_2 in the intersection of the second and the third, etc.

4. Computing plane areas with line integrals

Let us compute the area of the plane domain D , bounded by the oriented piecewise smooth curve $[ABCD A]$, which is its boundary ∂D (see Fig.14).

We see that the domain D bounded by the curve $[ABCD A]$ is simple w.r.t. Ox -axis, i.e. if $[a, b]$ is the projection of D on Ox -axis, then for any $x_0 \in (a, b)$ the straight line $X = x_0$ intersects the boundary ∂D in at most two distinct points. The following result gives the area of D as a line integral of the second type.

THEOREM 69. *With the above notation and hypotheses we have the following formula:*

$$(4.1) \quad \text{area}(D) = - \oint_{\partial D} y dx$$

PROOF. We know from a basic application of definite integral that

$$(4.2) \quad \text{area}(D) = \int_a^b [g(x) - f(x)] dx = \int_a^b g(x) dx - \int_a^b f(x) dx.$$

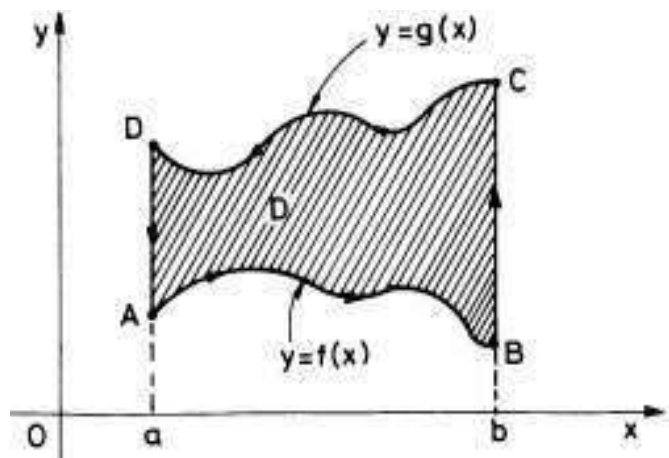

FIGURE 14

Since a parameterization of $[\widehat{CD}]$ is: $x = x, y = g(x), x \in [a, b]^-$ (this means that x goes from b to a) one has that $-\oint_{[\widehat{CD}]} ydx = \int_a^b g(x)dx$.

Since a parametrization of $[\widehat{AB}]$ is: $x = x, y = f(x), x \in [a, b]$, we obtain that $\oint_{[\widehat{AB}]} ydx = \int_a^b f(x)dx$. Now, if $B(b, y_B)$ and if $C(b, y_C)$, then

a parametrization of $[BC]$ is: $x = b, y = y \in [y_B, y_C]$. Hence $\oint_{[\widehat{BC}]} ydx =$

0. Similarly, $\oint_{[\widehat{DA}]} ydx = 0$, because $x = a$ is fixed on $[\widehat{DA}]$, so that $dx = 0$

on it. Finally, from these observations and from formula (4.2) we get:

$$\begin{aligned} -\oint_{\partial(D)} ydx &= -\oint_{[\widehat{CD}]} ydx - \oint_{[\widehat{DA}]} ydx - \oint_{[\widehat{AB}]} ydx - \oint_{[\widehat{BC}]} ydx = \\ &= \int_a^b g(x)dx - \int_a^b f(x)dx = \text{area}(D). \end{aligned}$$

□

REMARK 23. *If the domain D is simple w.r.t. Oy -axis, i.e. if $[c, d]$ is the projection of D on Oy -axis and if $y_0 \in (c, d)$, then the straight*

line $Y = y_0$ cuts the boundary ∂D of D in at most two points, then one can similarly prove the following formula:

$$(4.3) \quad \text{area}(D) = \oint_{\partial D} x dy.$$

If D is simple w.r.t. both axes then, by making the sum of formulas (4.1) and (4.3) we get a new "symmetric" formula":

$$(4.4) \quad \text{area}(D) = \frac{1}{2} \oint_{\partial D} x dy - y dx,$$

the boundary being directly oriented, i.e. in the trigonometric direction, "from Ox to Oy " (see Fig.14).

The symmetric formula 4.4 is very useful in applications. For instance, let us compute the area bounded by the asteroide $x = a \cos^3 t$, $y = a \sin^3 t$, $t \in [0, 2\pi]$. In this case the domain D is simple w.r.t. both axes. Since $dx = -3a \cos^2 t \sin t dt$ and $dy = 3a \sin^2 t \cos t dt$, then

$$\begin{aligned} x dy - y dx &= (3a^2 \sin^2 t \cos^4 t + 3a^2 \sin^4 t \cos^2 t) dt = \\ &= 3a^2 \sin^2 t \cos^2 t dt = \frac{3}{4} a^2 \sin^2 2t dt. \end{aligned}$$

Thus

$$\text{area}(D) = \frac{1}{2} \cdot \frac{3}{4} a^2 \int_0^{2\pi} \sin^2 2t dt = \frac{3}{8} a^2 \int_0^{2\pi} \frac{1 - \cos 4t}{2} dt = \frac{3a^2 \pi}{8}.$$

REMARK 24. If a bounded domain D is not simple, say with respect to the Ox -axis then, in our common examples, always it will be possible to divide it into a finite number of nonoverlapping (which have no small disc in their intersections!) simple domains w.r.t. Ox -axis and then to apply the above formulas for each of them. Moreover, we can even continue the process of dividing the obtained domains up to we obtain domains which are simple w.r.t. both axes. In Fig.15 we started with a domain D which is not simple w.r.t. Ox -axis and we divided it into three nonoverlapping subdomain D_1 , D_2 and D_3 , which are simple w.r.t. Ox -axis.

What is important to remark is that $\oint_{[A_2 A_6]} y dx + \oint_{[A_6 A_2]} y dx = 0$ and

$\oint_{[A_4 A_6]} y dx + \oint_{[A_6 A_4]} y dx = 0$. Here, since in the drawing of Fig.15 the segments on which we integrate are parallel to Oy -axis, each of these

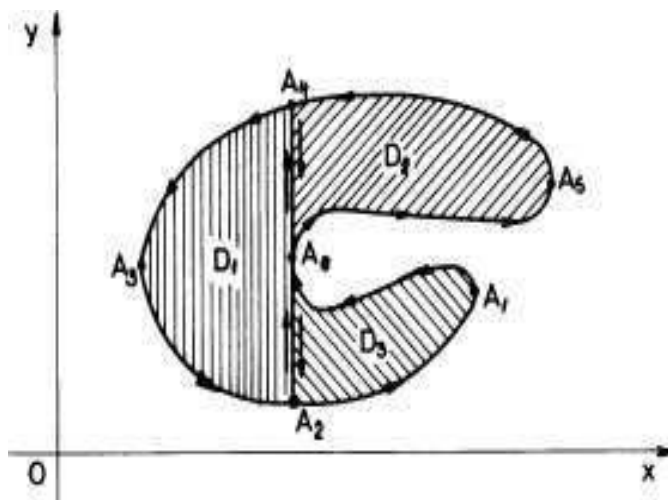

FIGURE 15

integral is zero ($dx = 0$). In general, these dividing curves can not be always chosen to be segments parallel with the Oy -axis. Hence, these

last two equalities come from the general relation: $\oint_{\gamma} \vec{F} \cdot d\vec{r} + \oint_{\gamma^-} \vec{F} \cdot d\vec{r} = 0$.

Let us use these observations to prove that formula (4.1) is true even in the general case when the domain is not simple w.r.t. to Ox -axis but it can be divided into a finite set of nonoverlapping simple domains w.r.t. Ox -axis. Look at Fig.15 and follow the next reasoning:

$$\begin{aligned}
 \text{area}(D) &= \text{area}(D_1) + \text{area}(D_2) + \text{area}(D_3) = - \oint_{\partial D_1} y dx - \oint_{\partial D_2} y dx - \oint_{\partial D_3} y dx = \\
 &= - \left[\oint_{[A_4 A_3 A_2]} y dx + \oint_{[A_2 A_6]} y dx + \oint_{[A_6 A_4]} y dx + \right. \\
 &\quad \left. + \oint_{[A_6 A_5 A_4]} y dx + \oint_{[A_4 A_6]} y dx + \oint_{[A_2 A_1 A_6]} y dx + \oint_{[A_6 A_2]} y dx \right] = \\
 &= - \left[\oint_{[A_4 A_3 A_2]} y dx - \oint_{[A_2 A_1 A_6]} y dx - \oint_{[A_6 A_5 A_4]} y dx \right] = - \oint_{\partial D} y dx.
 \end{aligned}$$

In this way we can extend all the formulas (4.1), (4.3) and (4.4) to the case when the domain D has its boundary ∂D a closed direct oriented

piecewise smooth curve and it can be decomposed into a finite union of simple nonoverlapping domains. We can apply the same principle to a domain D with its boundary ∂D a polygonal line (polygonal domains). It is very easy to see that each such domain can be decomposed into a finite union of nonoverlapping triangles. Since each triangle is a boundary of a convex (so that simple) domain, the above three formulas 4.1, 4.3 and 4.4 works also for such a "nonconvex" domain. Now, any domain D with its boundary a piecewise smooth curve can be well approximated with polygonal domains. Taking limits, we get that the three formulas works even in this last more general case.

Hence, we can reduce everything to triangles. Since even such operation to divide a polygonal domain into triangles can be complicated we give below a general and wise formula to compute the area of a bounded polygonal domain D .

EXAMPLE 71. Let us apply the formula (4.4) to find a general formula for the computation of the area of the domain D , bounded by a polygonal direct oriented line $[A_0A_1\dots A_{n-1}A_n]$, where $A_i(x_i, y_i)$, $i = 0, 1, \dots, n$ and $A_n = A_0$. Hence,

$$\text{area}(D) = \frac{1}{2} \sum_{j=0}^{n-1} \oint_{[A_jA_{j+1}]} xdy - ydx.$$

A natural parametrization of the oriented segment $[A_jA_{j+1}]$ is $x = x_j + t(x_{j+1} - x_j)$, $y = y_j + t(y_{j+1} - y_j)$, where $t \in [0, 1]$. Thus,

$$\begin{aligned} xdy - ydx &= \\ &= \{[x_j + t(x_{j+1} - x_j)](y_{j+1} - y_j) - [y_j + t(y_{j+1} - y_j)](x_{j+1} - x_j)\} dt = \\ &= (x_jy_{j+1} - y_jx_{j+1}) dt = (\overrightarrow{OA_j} \times \overrightarrow{OA_{j+1}}) \cdot \vec{k} dt. \end{aligned}$$

Hence,

$$(4.5) \quad \text{area}(D) = \frac{1}{2} \sum_{j=0}^{n-1} \int_0^1 (\overrightarrow{OA_j} \times \overrightarrow{OA_{j+1}}) \cdot \vec{k} dt. =$$

$$(4.6) \quad = \frac{1}{2} \left[\sum_{j=0}^{n-1} (\overrightarrow{OA_j} \times \overrightarrow{OA_{j+1}}) \right] \cdot \vec{k}.$$

This last expression of the area does not depend on the origin O or of the coordinate system. Thus, a very nice consequence of the vector formula 4.5 is the following.

THEOREM 70. Let $A_0, A_1, \dots, A_{n-1}, A_n = A_0$ and M be $n+1$ distinct points in a plane (P). Then the quantity $\sum_{j=0}^{n-1} \overrightarrow{MA_j} \times \overrightarrow{MA_{j+1}}$ is a real number which does not depend on M . Its absolute value is equal to two times the area of the polygonal domain D bounded by the polygonal line $[A_0A_1\dots A_{n-1}A_n]$.

REMARK 25. Let D be a plane bounded domain with its boundary ∂D a "closed" piecewise smooth direct oriented curve. For a moving point M on the oriented curve ∂D we denote by $\vec{r} = \overrightarrow{OM}$ the position vector of M w.r.t. a fixed point O . Let us fix for a moment a Cartesian plane frame $\{O; \vec{i}, \vec{j}\}$ and the corresponding two axes Ox and Oy . By $d\vec{r}$ we mean the vector $d\vec{r} = dx\vec{i} + dy\vec{j}$ which can be conceived as a small difference $\vec{r}' - \vec{r}$. If we compute $\vec{r} \times d\vec{r}$ we obtain $(xdy - ydx)\vec{k}$, where $\vec{k} = \vec{i} \times \vec{j}$ is an orthogonal versor on the plane (P) in which D is. Its sense is closely connected with the orientation of ∂D by using the screw rule ($\{O; \vec{i}, \vec{j}, \vec{k}\}$ is a direct Cartesian coordinate system: $\vec{k} = \vec{i} \times \vec{j}$). Thus formula (4.4) can also be written:

$$(4.7) \quad \text{area}(D) = \frac{1}{2} \oint_{\partial D} (\vec{r} \times d\vec{r}) \cdot \vec{k}.$$

Since this formula is independent on the coordinate system $\{O; \vec{i}, \vec{j}\}$, we see what is intuitively clear that the area does not depend on a fixed coordinate system. This is why formula (4.7) is useful in many applications.

5. Supplementary remarks on line integrals

We saw that a field $\vec{F} = P\vec{i} + Q\vec{j} + R\vec{k}$ is conservative if and only if the differential form $\omega = Pdx + Qdy + Rdz$ is exact, i.e. if it can be realized as the first differential of a primitive function $U(x, y, z)$, namely if $dU = \omega$, which is equivalent to saying that $\frac{\partial U}{\partial x} = P$, $\frac{\partial U}{\partial y} = Q$ and $\frac{\partial U}{\partial z} = R$. Let us now prove the complicated result stated in remark 21 for some special domains, namely starred domains. We say that the differential form ω is *closed* if P, Q, R are of class C^1 and $\text{curl } \vec{F} = \vec{0}$ on D .

DEFINITION 22. A subset S of \mathbb{R}^3 (or \mathbb{R}^2 , or \mathbb{R}) is said to be *starred* if there is a point $A \in S$ such that for any other point $M \in S$ the

segment $[AM]$ is contained in S . This point A is called a center of the starred set S . In particular any starred subset is a connected subset.

Any convex subset S is a starred subset, any fixed point A of S being a center of it. In Fig.16 we see some examples of starred, convex, nonstarred, or nonconvex plane subsets.

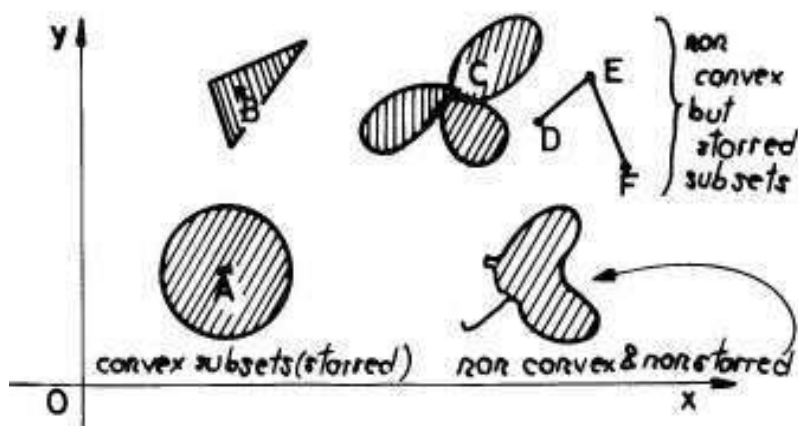

FIGURE 16

In Fig.17 we see the same type of examples in space.

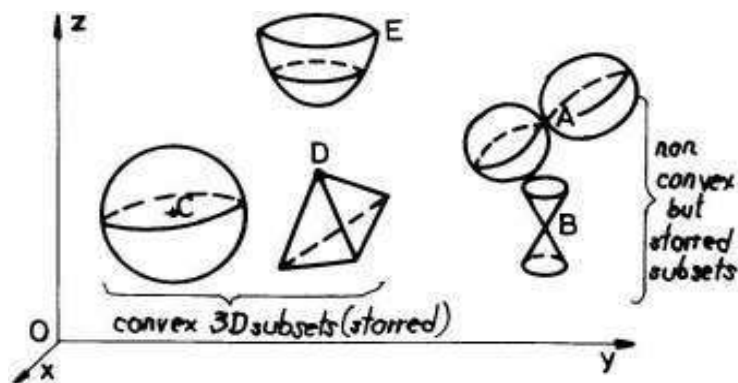

FIGURE 17

Recall that an direct oriented segment $[AM]$, $A(a, b, c)$, $M(x, y, z)$ of a line is a smooth deformation of the direct oriented interval $[0, 1]$ through the classical parametrization path $\vec{r}(t) = f_1(t)\vec{i} + f_2(t)\vec{j} +$

$f_3(t)\vec{k}$, $t \in [0, 1]$, where

$$\begin{cases} f_1(t) = a + (x - a)t \\ f_2(t) = b + (y - b)t \\ f_3(t) = c + (z - c)t \end{cases}, t \in [0, 1].$$

THEOREM 71. *Let D be a starred domain in \mathbb{R}^3 and let $\omega = Pdx + Qdy + Rdz$ be a closed differential form on D , i.e. P, Q, R are of class C^1 and $\text{curl } \vec{F} = \vec{0}$ on D . Then ω is exact on D , i.e. there exists a scalar function $U(x, y, z)$ defined on D , such that its partial derivatives $\frac{\partial U}{\partial x}$, $\frac{\partial U}{\partial y}$, $\frac{\partial U}{\partial z}$ exist and $\frac{\partial U}{\partial x} = P$, $\frac{\partial U}{\partial y} = Q$ and $\frac{\partial U}{\partial z} = R$, i.e. U is a primitive or a potential function for \vec{F} . Here \vec{F} is a field with components P, Q and R .*

PROOF. Let $A(a, b, c)$ be a centre of the starred domain D and let $M_0(x_0, y_0, z_0)$ be an arbitrary moving point of D . Since D is starred and A is a centre of it, the segment $[AM_0]$ is contained in D . We define:

$$\begin{aligned} U(x_0, y_0, z_0) &= \oint_{[AM_0]} Pdx + Qdy + Rdz = \\ (5.1) &= \int_0^1 [P(f_1(t), f_2(t), f_3(t))(x_0 - a) + Q(f_1(t), f_2(t), f_3(t))(y_0 - b) + \\ &\quad + R(f_1(t), f_2(t), f_3(t))(z_0 - c)] dt. \end{aligned}$$

Don't forget that

$$\begin{cases} f_1(t) = a + (x_0 - a)t \\ f_2(t) = b + (y_0 - b)t \\ f_3(t) = c + (z_0 - c)t \end{cases}, t \in [0, 1].$$

Let us apply Leibniz' formula in the integral (5.1), with parameters x_0, y_0, z_0 , in order to compute the partial derivatives of U . The conditions of theorem 51 are satisfied. We also use the condition $\text{curl } \vec{F} = \vec{0}$, i.e. $\frac{\partial P}{\partial y} = \frac{\partial Q}{\partial x}$, $\frac{\partial Q}{\partial z} = \frac{\partial R}{\partial y}$ and $\frac{\partial R}{\partial x} = \frac{\partial P}{\partial z}$:

$$\begin{aligned} \frac{\partial U}{\partial x_0}(x_0, y_0, z_0) &= \int_0^1 [P(f_1(t), f_2(t), f_3(t)) + \frac{\partial P}{\partial x}(f_1(t), f_2(t), f_3(t))t(x_0 - a) + \\ &\quad + \frac{\partial Q}{\partial x}(f_1(t), f_2(t), f_3(t))t(y_0 - b) + \frac{\partial R}{\partial x}(f_1(t), f_2(t), f_3(t))t(z_0 - c)] dt = \\ &= \int_0^1 [P(f_1(t), f_2(t), f_3(t)) + \frac{\partial P}{\partial x}(f_1(t), f_2(t), f_3(t))t(x_0 - a) + \\ &\quad + \frac{\partial P}{\partial y}(f_1(t), f_2(t), f_3(t))t(y_0 - b) + \frac{\partial P}{\partial z}(f_1(t), f_2(t), f_3(t))t(z_0 - c)] dt = \end{aligned}$$

$$\begin{aligned}
 &= \int_0^1 \frac{d}{dt} [tP(f_1(t), f_2(t), f_3(t))] dt = tP(f_1(t), f_2(t), f_3(t)) \Big|_0^1 = \\
 &= P(f_1(1), f_2(1), f_3(1)) = P(x_0, y_0, z_0).
 \end{aligned}$$

We leave the reader to use the same methods in order to prove that $\frac{\partial U}{\partial y_0}(x_0, y_0, z_0) = Q(x_0, y_0, z_0)$ and that $\frac{\partial U}{\partial z_0}(x_0, y_0, z_0) = R(x_0, y_0, z_0)$. \square

If the segments $[AB]$, $[BC]$ and $[CM_0]$ are contained in D , then we can integrate on the path $[ABCM_0]$ (see Fig.19) and we can define:

$$U(x_0, y_0, z_0) = \oint_{[ABCM_0]} Pdx + Qdy + Rdz.$$

The computations are easier in this case (do them!). Finally we get the same function U defined on D (if A is fixed). For instance, let us use this last idea to find a primitive of the form $\omega = yzdx + zxdy + xydz$. Since $\text{curl } \vec{F} = \vec{0}$, there exists a primitive (it is clear that $D = \mathbb{R}^3$ is a starred domain) $U(x, y, z)$. Let us fix a centre $A(0, 1, 2)$ (see Fig.18)

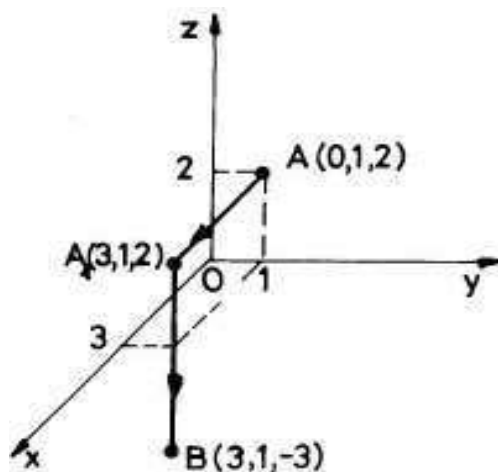

FIGURE 18

and let us compute the value of U at $B(3, 1, -3)$:

$$\begin{aligned}
 U(3, 1, -3) &= \int_{A(0,1,2)}^{A_1(3,1,2)} yzdx + zxdy + xydz + \int_{A_1(3,1,2)}^{B(3,1,-3)} yzdx + zxdy + xydz = \\
 &= \int_0^3 1 \cdot 2 \cdot dx + \int_2^{-3} 3 \cdot 1 \cdot dz = -9.
 \end{aligned}$$

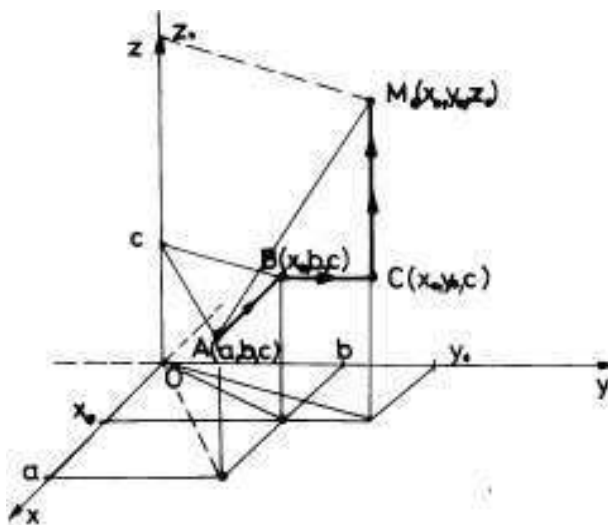

FIGURE 19

REMARK 26. Let D be a plane simple connected domain and let $\vec{F} : D \rightarrow \mathbb{R}^2$, $\vec{F} = (P, Q)$ be a plane field of class C^1 on D such that $\frac{\partial P}{\partial y} = \frac{\partial Q}{\partial x}$ on D . Then the field is conservative, i.e. there exists a scalar function $U(x, y)$ such that $\text{grad} U = \vec{F}$, or $\frac{\partial U}{\partial x} = P$ and $\frac{\partial U}{\partial y} = Q$. Our above experience tells us that this function must be of the form:

$$(5.2) \quad U(x, y) = \oint_{\gamma} P dx + Q dy,$$

where γ is a smooth oriented curve contained in D and which connect a fixed "for ever" point $M_0(x_0, y_0)$ of D and the moving point $M(x, y)$ on D . Two problems arises: 1) to prove that the definition does not depend on the connecting curve γ and 2) to prove that $\frac{\partial U}{\partial x} = P$ and $\frac{\partial U}{\partial y} = Q$. The second problem is easy if we succeed to prove the first. Indeed, if the definition (5.2) does not depend on the path γ , then the integral $\oint P dx + Q dy$ is independent on path, i.e. it is zero on any "closed" path in D . And conversely! Let us fix a point $L(a, b)$ in D and let us take an open disc $B(L, r)$, $r > 0$, which is contained in D . Since this ball is a starred domain, applying the plane variant of theorem 71 we see that the restriction of U to this ball is a primitive for \vec{F} on D . In particular $\frac{\partial U}{\partial x}(a, b) = P(a, b)$ and $\frac{\partial U}{\partial y}(a, b) = Q(a, b)$. Hence we need only to prove

1). As we just remarked, it is enough to prove that $\oint_{\Gamma} Pdx + Qdy = 0$ for any smooth closed oriented curve $\Gamma \subset D$, if $\frac{\partial P}{\partial y} = \frac{\partial Q}{\partial x}$ on D . Since any such curve Γ can be well and uniformly approximated with closed polygonal lines, it is enough to prove $\oint_{[A_0A_1\dots A_{n-1}A_n]} Pdx + Qdy = 0$ for any closed oriented polygonal line $[A_0A_1\dots A_{n-1}A_n]$, $A_n = A_0$. We can divide the domain bounded by this polygonal line in oriented triangles, such that the orientation of each triangle is uniquely determined (induced) by the orientation of $[A_0A_1\dots A_{n-1}A_n]$. Hence it will be sufficient to prove that if $\frac{\partial P}{\partial y} = \frac{\partial Q}{\partial x}$ on a domain Ω which contains a triangle $[A_0A_1A_2]$, then $\oint_{[A_0A_1A_2]} Pdx + Qdy = 0$. Since always we can take a starred domain Δ which is contained in D and which contains our given triangle $[A_0A_1A_2]$, we can apply theorem 71 to find a potential function U for \vec{F} restricted to Δ . Now, theorem 67 says that $\oint_{[A_0A_1A_2]} Pdx + Qdy = 0$, i.e. what we wanted to prove.

6. Problems and exercises

1. Compute the length of the curve $y(x) = a \cosh \frac{x}{a}$, $x \in [-a, a]$, $a > 0$.

2. Let $\Gamma : \begin{cases} x = 3t + 1 \\ y = 4t + 1 \end{cases}, t \in [-1, 1]$. Find its length and the coordinates of its mass centre if the density function is $f(x, y) = |x|$.

3. On the segment $[AB]$, $A(1, 1)$, $B(3, 4)$ we consider a density function $f(x, y) = x^2 + y^2$. Find its mass.

4. On the arc of a circle $[\widehat{ACB}]$ with radius 2, $A(2, 0)$, $B(-2, 0)$ and $C(0, 2)$ we consider a wire with density function $f(x, y) = \frac{1}{\sqrt{x^2 + y^2}}$.

Find the mass, the coordinates of the mass centre and the moment of inertia w.r.t. Oy -axis.

5. The segment $[0, 2\pi]$ is deformed into a helix: $\begin{cases} x = a \cos \theta \\ y = a \sin \theta \\ z = b\theta \end{cases}$,

where $a, b > 0$ and $\theta \in [0, 2\pi]$. Assume that the density function is $f(x, y, z) = 4$. Compute the mass, the coordinates of the mass centre and the moment of inertia w.r.t. Oz -axis.

6. The wire $\Gamma = \{M(x, y) : (x - 1)^2 + y^2 = 1\}$, with the density function $f(x, y) = x$ rotates around Ox -axis. Find its moment of inertia.

7. Let $A(a, 0)$, $B(0, b)$, $n = [AB]$, be the segment AB and let $m = \widehat{[AB]}$, be the arc of the ellipse $\frac{x^2}{a^2} + \frac{y^2}{b^2} = 1$ which connects A and B . The metallic frame $[AmBnA]$ is loaded with a density function $f(x, y)$ at the point $M(x, y)$, which is three times the value of the projection of M on the Ox -axis. Find its mass centre.

8. Let $A(1, 1)$, $B(1, -1)$ and $\widehat{[AOB]}$ be the arc of the parabola $x = y^2$. The frame $\widehat{[AOB]} \cup [AB]$ with the density function $f(x, y) = x + 1$ rotates around Ox -axis. Find its moment of inertia.

9. Let $A(1, 1)$ and $B(2, 0)$ be two points in the xOy -plane.

Find $I = \int_{[OA] \cup [AB]} (x^3 + y^3) ds$.

10. Find $\int_C xy ds$, where C is the square $|x| + |y| = a > 0$.

11. Find $I = \int_C \frac{ds}{\sqrt{x^2 + y^2 + 4}}$, where C is the segment which connect the points $O(0, 0)$ and $A(1, 2)$.

12. Find $\int_C xy ds$, where C is the curve $\frac{x^2}{a^2} + \frac{y^2}{b^2} = 1$, $x, y \geq 0$.

13. Find $\int_C \frac{ds}{x^2 + y^2 + z^2}$, where $C : \begin{cases} x = 2 \cos t \\ y = 2 \sin t \\ z = bt \end{cases}, t \in [0, 4\pi]$.

14. Find the length of the arc of a conic helix: $x = 2e^t \cos t$, $y = 2e^t \sin t$, $z = 2e^t$, between $O(0, 0, 0)$ and $A(2, 0, 2)$.

15. Find the length and the mass centre of the arc of a cycloid:

$$\begin{cases} x = a(t - \sin t) \\ y = a(1 - \cos t) \end{cases}, t \in [0, \pi].$$

16. Find the mass of the ellipse-wire $\frac{x^2}{a^2} + \frac{y^2}{b^2} = 1$ if its density function is $f(x, y) = |y|$.

17. Find $\int_C (x + y) ds$, where C is the arc: $\begin{cases} x = t \\ y = \frac{3t^2}{\sqrt{2}} \\ z = t^3 \end{cases}, t \in [0, 1]$.

18. Use Riemann sums to find the side area of the parabolic cylinder $y = \frac{3}{8}x^2$, bounded by the planes $z = 0$, $x = 0$, $z = x$, $y = 6$.

19. Compute $\oint_C x dy$, where C is the direct oriented (trigonometric sense) curve which bounds the triangle realized by the coordinates axes and the line $\frac{x}{2} + \frac{y}{3} = 1$.

20. Compute $\oint_C xy dx + x^2 dy$, where C is the arc of the parabola $y = 4x^2$ between $O(0, 0)$ and $A(1, 4)$, clockwise oriented.

21. Find the work of the field $\vec{F}(x, y) = xy\vec{i} + x^2\vec{j}$ on the following oriented curves:

a) the rectangle frame $[OABCO]$, where $A(0, 1)$, $B(2, 1)$ and $C(2, 0)$. The orientation is $O \rightarrow A \rightarrow B \rightarrow C \rightarrow O$.

b) the curve $[OBAO]$, where $[OB]$ and $[AO]$ are segments of lines, $[BA]$ is an arc of a circle of radius 2, $B(2, 0)$ and the angle $\angle(AOB)$ is equal to 60° . The orientation is $O \rightarrow B \rightarrow A \rightarrow O$.

c) the triangle frame $[ABCA]$, where $A(1, 2)$, $B(3, 4)$ and $C(5, 1)$. The orientation is $A \rightarrow B \rightarrow C \rightarrow A$.

d) the curve $[OmAnO]$, where $A(1, 1)$, $[OmA]$ is the arc of the parabola $y = x^2$ and $[AnO]$ is the arc of the parabola $x = y^2$. The orientation is $O \rightarrow A \rightarrow O$.

22. Find $\oint_C \vec{F} \cdot d\vec{r}$, where $\vec{r}(t) = t\vec{i} + t^2\vec{j} + t^3\vec{k}$, $t \in [0, 1]$ and

$\vec{F}(x, y, z) = (y, z, 2x)$. The orientation of C is the direct orientation induced by the moving of t from 0 to 1.

23. Find the work of the field $\vec{F}(x, y, z) = xy\vec{i} + xz\vec{j} + yz\vec{k}$ on the polygonal frame $[ABCO]$, where $A(3, 0, 0)$, $B(3, 3, 0)$ and $C(0, 3, 3)$. The orientation is $A \rightarrow B \rightarrow C \rightarrow O$. Is this field a conservative field? If it is so, compute again easier the work of the field!

24. Find $\alpha \in \mathbb{R}$ such that the integral $I(\alpha) = \oint_{(2,3)} (\alpha xy - 1)dx + 3x^2 dy$

does not depend on path. Then compute $\oint_{(1,1)} (\alpha xy - 1)dx + 3x^2 dy$ for

this last found value of α .

25. Prove that the following differential forms are exact on some simple connected domains (describe them!) and then find their primitives.

a) $\frac{dx+dy+dz}{x+y+z}$; b) $\frac{xdx+ydy+zdz}{\sqrt{x^2+y^2+z^2}}$; c) $\frac{xdy+ydx}{\sqrt{x^2+y^2}}$.

26. Use the formulas: $area(D) = \oint_{\partial D} xdy = -\oint_{\partial D} ydx = \frac{1}{2} \oint_{\partial D} xdy - ydx$

in order to find the areas of the figures bounded by the following closed curves:

a) $x^2 + \frac{y^2}{4} = 1$; b) $\left\{ \begin{array}{l} x = a \cos^3 t \\ y = a \sin^3 t \end{array} \right., t \in [0, 2\pi]$. c) $\left\{ \begin{array}{l} x = t - \sin t \\ y = 1 - \cos t \end{array} \right., t \in [0, 2\pi]$, and the Ox -axis.

27. Find the length and the area bounded by

$$\Gamma : \begin{cases} x = R(2 \cos t - \cos 2t) \\ y = R(2 \cos t - \sin 2t) \end{cases}, t \in [0, 2\pi], R > 0.$$

$$28. \text{ Let } \Gamma : \begin{cases} x = t \cos t \\ y = t \sin t \\ z = t \end{cases}, t \in [0, \pi] \text{ be a wire with the density}$$

function $f(x, y, z) = x^2 + y^2$. Find its static moment relative to xOy -plane.

29. Let $\Gamma = \{M(x, y) : x^2 + y^2 = a^2 \text{ and } x + y + z = 0\}$ with its direct orientation induced by the direct orientation of the plane xOy . Compute the work of $\vec{F} = (1, x, z)$ on Γ .

30. Let P_1 be the parabola $x = y^2$ and let P_2 be the unique parabola which contains the points $B(3, -\sqrt{3})$, $A(3, \sqrt{3})$ and $C(2, 0)$. Find the area bounded by these parabolas.

31. Compute:

a) $\int_{(-1,1)}^{(2,-1)} x(1+x)dx - y(1+y)dy$; b) $\int_{(0,0,0)}^{(-2,1,5)} x^2 dx + \sqrt{y} dy - z\sqrt{z} dz$;

32. Find $V(x, y)$ if $dV = (4x + 2y)dx + (2x - 6y)dy$. Use this to solve the differential equation $y' = \frac{4x-6y}{6y-2x}$.

CHAPTER 6

Double integrals

1. Double integrals on rectangles.

A *lamina* or a *thin plate* is a bounded plane closed domain (an open and connected bounded subset of \mathbb{R}^2 together with its boundary) D with a *density function* $f(x, y)$ defined on it. In practical applications $f(x, y)$ is greater or equal than zero. But here we shall consider the density function $f : D \rightarrow \mathbb{R}$ to have arbitrary values and to be piecewise continuous. This means the f is bounded and continuous on D except maybe a finite union of points or smooth curves (which have area zero!). The boundary ∂D of D is considered to be a piecewise smooth curve (in particular it has a zero area!). Let us recall the definition 7 of the area of a plane figure. We say that a plane figure A has area (measure) $\sigma(A)$ if for any $\varepsilon > 0$ there exist two elementary figures (finite union of nonoverlapping (their intersections does not contain interior points!) simple rectangles $[a, b] \times [c, d]$) E_i and E_o such that $E_i \subset A \subset E_o$, $area(E_o) - area(E_i) < \varepsilon$ and $area(E_o) \leq \sigma(A) \leq area(E_i)$. This means that we can well approximate the figure A with elementary figures from inside and from outside too. We know that the domain D which is the support of a lamina defined above has an area (because ∂D is piecewise smooth!). We always in this chapter assume this and, because of this type of approximation, we begin with a particular form of D , namely when D is a simple rectangle $[a, b] \times [c, d]$ and $f : [a, b] \times [c, d] \rightarrow \mathbb{R}$ is a continuous function defined on it (any piecewise continuous function can well be approximated with continuous functions!). Let the rectangle (as a surface!) $D = [ABCE]$ in Fig.1.

Let $\Delta_x : a = x_0 < x_1 < \dots < x_n = b$ be an arbitrary division of $[a, b]$ and let $\Delta_y : c = y_0 < y_1 < \dots < y_m = d$ be an arbitrary division of $[c, d]$. Let $D_{ij} = [x_{i-1}, x_i] \times [y_{j-1}, y_j]$ and let $P_{ij}(c_i, d_j)$ be a marking point in D_{ij} for any $i = 1, 2, \dots, n$ and $j = 1, 2, \dots, m$. By definition the area of D_{ij} is $(x_i - x_{i-1})(y_j - y_{j-1})$ and $D = \cup_{i,j} D_{ij}$. Let us assume now that $\|\Delta_x\| \rightarrow 0$ and $\|\Delta_y\| \rightarrow 0$, when $n \rightarrow \infty$ and $m \rightarrow \infty$, i.e. $area(D_{ij}) \rightarrow 0$. Hence we can well approximate the density function $f(x, y)$ on D_{ij} with its value at the marked point P_{ij} , i.e. $f(x, y) \approx f(c_i, d_j)$ for any $(x, y) \in D_{ij}$. We can remark that $\{c_i\}$

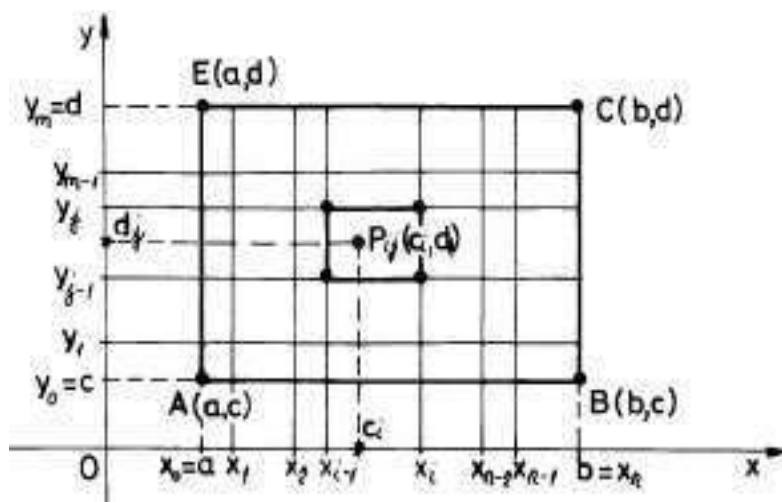

FIGURE 1

and $\{d_j\}$ are sets of marking points for Δ_x and Δ_y respectively. Thus we can well approximate:

$$(1.1) \quad \text{mass}(D) \approx \sum_{i=1}^n \sum_{j=1}^m f(c_i, d_j) \text{area}(D_{ij}) \stackrel{\text{def}}{=} S_f(\Delta_x, \Delta_y, \{(c_i, d_j)\})$$

Such a sum is called a *double Riemann sum* which corresponds to divisions Δ_x, Δ_y , to marking points $\{P(c_i, d_j)\}$ and to function $f(x, y)$. We can also introduce double Darboux sums:

$$s_{\Delta_x, \Delta_y} = \sum_{i=1}^n \sum_{j=1}^m m_{ij} \text{area}(D_{ij}) \quad \text{and} \quad S_{\Delta_x, \Delta_y} = \sum_{i=1}^n \sum_{j=1}^m M_{ij} \text{area}(D_{ij}),$$

where $m_{ij} = \inf_{(x,y) \in D_{ij}} f(x, y)$ and $M_{ij} = \sup_{(x,y) \in D_{ij}} f(x, y)$.

It is not so difficult to state and to prove analogous results to those given in chapter II. For instance, any double Riemann sum

$$S_f(\Delta_x, \Delta_y, \{(c_i, d_j)\})$$

is greater or equal than its corresponding s_{Δ_x, Δ_y} and it is also less or equal than S_{Δ_x, Δ_y} .

DEFINITION 23. A function $f(x, y)$ defined on a simple rectangle D is Riemann integrable on D if there exists a real number I such that for any $\varepsilon > 0$, there exists a small number δ (depending on ε) such that if $\|\Delta_x\| < \delta$ and $\|\Delta_y\| < \delta$, then $|I - S_f(\Delta_x, \Delta_y, \{(c_i, d_j)\})| < \varepsilon$ for any marking points $\{(c_i, d_j)\}$ corresponding to the divisions $\|\Delta_x\|$ and $\|\Delta_y\|$. The number I is unique, it is called the double integral of

f on D and it is denoted by $I = \iint_D f(x, y) dx dy$. Here $dx dy$ is said to be a (small) element of area of D . This is the virtual notation for $(x_i - x_{i-1})(y_j - y_{j-1})$. In this particular case (the case of a rectangle) $dx dy = dx \cdot dy$. We shall see that in general (for arbitrary domains) this is not true (for instance in the case of a disc).

We can give here the analogous theorems for the theorems 14 and 16.

THEOREM 72. (*Darboux criterion*) $f : D \rightarrow \mathbb{R}$ is Riemann integrable if and only if for any $\varepsilon > 0$, there exists $\delta > 0$ such that whenever $\|\Delta_x\| < \delta$ and $\|\Delta_y\| < \delta$ then one has that $S_{\Delta_x, \Delta_y} - s_{\Delta_x, \Delta_y} < \varepsilon$.

A direct consequence of this criterion is the following basic theorem.

THEOREM 73. Any continuous function $f : D = [a, b] \times [c, d] \rightarrow \mathbb{R}$ is Riemann integrable. Moreover, any piecewise continuous function f (see its definition above) on a rectangle is also Riemann integrable.

The following theorem is a basic result for what we shall study here w.r.t. "multiple integrals", i.e. integrals in 2 or 3 dimensions.

THEOREM 74. (*iterative formula*) Let $f : D \rightarrow \mathbb{R}$ be a continuous function on a rectangle $D = [a, b] \times [c, d]$. Then f is integrable and

$$(1.2) \quad \iint_D f(x, y) dx dy = \int_a^b \left(\int_c^d f(x, y) dy \right) dx = \int_c^d \left(\int_a^b f(x, y) dx \right) dy.$$

These last formulas says that either we integrate $f(x, y)$ w.r.t. y from c to d and obtain a new function of x which is finally integrated from a to b (the first equality), or we firstly integrate $f(x, y)$ w.r.t. x from a to b and obtain a new function of y which is finally integrated from c to d (the second equality).

PROOF. We preserve the above notation in the next considerations. Let $J = \iint_D f(x, y) dx dy$, $I_1 = \int_a^b \left(\int_c^d f(x, y) dy \right) dx$ and $I_2 = \int_c^d \left(\int_a^b f(x, y) dx \right) dy$. The number J exists because of theorem 73. The integral $I(x) = \int_c^d f(x, y) dy$ is an integral with a parameter x . Thus $I_1 = \int_a^b I(x) dx$ and we can well approximate it with Riemann sums of

the following type:

$$(1.3) \quad I_1 \approx \sum_{i=1}^n I(c_i)(x_i - x_{i-1}).$$

But each integral $I(c_i) = \int_c^d f(c_i, y)dy$ can be approximated by Riemann sums of the form:

$$(1.4) \quad I(c_i) \approx \sum_{j=1}^m f(c_i, d_j^{(i)})(y_j - y_{j-1}) \approx \sum_{j=1}^m f(c_i, d_j)(y_j - y_{j-1}),$$

because d_j and $d_j^{(i)}$ are both in $[y_{j-1}, y_j]$, $\|\Delta_y\| \rightarrow 0$ and f is continuous. Here Δ_y is the union of all divisions $\Delta_y^{(i)}$ considered for each c_i , $i = 1, 2, \dots, n$. Now we come back to formula (1.3) with the approximation of $I(c_i)$ from formula (1.4) and find:

$$I_1 \approx \sum_{i=1}^n \sum_{j=1}^m f(c_i, d_j)(y_j - y_{j-1})(x_i - x_{i-1}) = S_f(\Delta_x, \Delta_y, \{(c_i, d_j)\}).$$

Thus I_1 can be well approximated with double Riemann sums of the type

$S_f(\Delta_x, \Delta_y, \{(c_i, d_j)\})$ Since f is Riemann integrable, all of these sums have a unique limit point $J = \iint_D f(x, y)dxdy$. Hence $I_1 = J$.

Similarly we can prove (do it!) that $J = I_2$, where $I_2 = \int_c^d J_1(y)dy$ and $J_1(y) = \int_a^b f(x, y)dx$. Therefore, $I_1 = I_2 = J$. \square

EXAMPLE 72. Find the mass of the plate $D = [0, 1] \times [1, 2]$ if the density function is $f(x, y) = x^2y + xy^2$. We use the iterative formula (1.2):

$$\begin{aligned} \text{mass}(D) &= \iint_D (x^2y + xy^2)dxdy = \int_0^1 \left(\int_1^2 (x^2y + xy^2)dy \right) dx = \\ &= \int_0^1 \left(x^2 \frac{y^2}{2} + x \frac{y^3}{3} \right) \Big|_1^2 dx = \int_0^1 \left(x^2 \frac{2^2}{2} + x \frac{2^3}{3} - x^2 \frac{1}{2} - x \frac{1}{3} \right) dx = \\ &= \int_0^1 \left(\frac{3}{2}x^2 + \frac{7}{3}x \right) dx = \left(\frac{3}{2} \frac{x^3}{3} + \frac{7}{3} \frac{x^2}{2} \right) \Big|_0^1 = \frac{1}{2} + \frac{7}{6} = \frac{5}{3}. \end{aligned}$$

The other variant of the formula is "easier" to work with.

$$\iint_D (x^2y + xy^2)dxdy = \int_1^2 \left(\int_0^1 (x^2y + xy^2)dx \right) dy =$$

$$\int_1^2 \left(\frac{x^3}{3}y + \frac{x^2}{2}y^2 \Big|_0^1 \right) dy = \int_1^2 \left(\frac{y}{3} + \frac{y^2}{2} \right) dy = \left(\frac{y^2}{6} + \frac{y^3}{6} \right) \Big|_1^2 = \frac{5}{3}.$$

EXAMPLE 73. Let us compute the mass centre coordinates of D when the density function is a piecewise continuous function $f(x, y)$. Look at Fig.1 and let us approximate the static moment relative to Oy -axis of the rectangle $D_{ij} = [x_{i-1}, x_i] \times [y_{j-1}, y_j]$ by $c_i f(c_i, d_j) \text{area}(D_{ij})$. Thus the "global" static moment of D relative to Oy -axis can be well approximated by

$$\sum_{i=1}^n \sum_{j=1}^m c_i f(c_i, d_j) (y_j - y_{j-1}) (x_i - x_{i-1}) = S_{xf}(\Delta_x, \Delta_y, \{(c_i, d_j)\}),$$

a Riemann sum of function $xf(x, y)$. Hence the theoretical static moment M_y of the lamina (D, f) relative to Oy -axis can be computed by the formula:

$$(1.5) \quad M_y = \iint_D xf(x, y) dx dy.$$

In the same manner we can deduce a formula for the static moment M_x of the lamina (D, f) w.r.t. Ox -axis:

$$(1.6) \quad M_x = \iint_D yf(x, y) dx dy.$$

The coordinates (x_G, y_G) of the mass centre G of the lamina (D, f) are defined such that if we concentrate the mass of D at the point G , then both moments of this last system must coincide with the correspondent global moments, i.e.

$$M_y = \iint_D xf(x, y) dx dy = x_G \cdot \text{mass}(D),$$

and

$$M_x = \iint_D yf(x, y) dx dy = y_G \cdot \text{mass}(D).$$

Thus we just obtained the basic formulas:

$$(1.7) \quad x_G = \frac{\iint_D xf(x, y)dx dy}{\iint_D f(x, y)dx dy}, \text{ and } y_G = \frac{\iint_D yf(x, y)dx dy}{\iint_D f(x, y)dx dy}.$$

For instance, let us compute the mass centre of the square $D = [-1, 1] \times [0, 2]$ with the density function $f(x, y) = y$. First of all let us remark that D is symmetric w.r.t. Oy -axis. Moreover, the distribution of the mass is symmetric w.r.t. the same axis: $f(x, y) = f(-x, y) = y$. Thus, G is on Oy -axis, i.e. $x_G = 0$. In order to compute y_G we need to compute two integrals:

$$\iint_D f(x, y)dx dy = \iint_D ydx dy = \int_{-1}^1 \left(\int_0^2 ydy \right) dx = 2 \int_{-1}^1 dx = 4$$

and

$$\iint_D yf(x, y)dx dy = \iint_D y^2dx dy = \int_{-1}^1 \left(\int_0^2 y^2dy \right) dx = \frac{8}{3} \int_{-1}^1 dx = \frac{16}{3}.$$

Hence $y_G = \frac{\frac{16}{3}}{4} = \frac{4}{3}$. We leave as an exercise to the reader to prove that $y_G = \frac{4}{3}$ is the mass centre of the wire $x = 0, y = t \in [0, 2]$, with the same density function $f(x, y) = y$. Use your "static" feeling to anticipate this result and to explain this feeling.

EXAMPLE 74. Let us deduce the moments of inertia I_{Ox} of a simple rectangle D with density function $f(x, y)$, when D moves around Ox -axis. For a material point $P(x, y)$ with a mass m , this moment of inertia is equal to y^2m , i.e. the mass m multiplied by the square of the distance from P to the rotation axis Ox . Thus, we can well approximate the moment of inertia of the rectangle D_{ij} w.r.t. Ox -axis with the quantity $d_j^2 f(c_i, d_j) \text{area}(D_{ij})$. Thus the global moment of inertia of D relative to Ox -axis can be well approximated by

$$\sum_{i=1}^n \sum_{j=1}^m d_j^2 f(c_i, d_j)(y_j - y_{j-1})(x_i - x_{i-1}) = S_{y^2 f}(\Delta_x, \Delta_y, \{(c_i, d_j)\}).$$

Hence, we can write the formula:

$$(1.8) \quad I_{Ox} = \iint_D y^2 f(x, y)dx dy.$$

Analogously, we can deduce the following formula for the moment of inertia of D w.r.t. Oy -axis:

$$(1.9) \quad I_{Oy} = \iint_D x^2 f(x, y) dx dy.$$

The sum $I_O = I_{Ox} + I_{Oy} = \iint_D (x^2 + y^2) f(x, y) dx dy$ is called the moment of inertia w.r.t. O .

Let us compute for instance the moment I_{Oy} of $D = [0, 1] \times [0, 1]$ with the density function $f(x, y) = xy$.

$$\begin{aligned} I_{Oy} &= \iint_D x^2 f(x, y) dx dy = \int_0^1 \left(\int_0^1 x^3 y dy \right) dx = \\ &= \int_0^1 x^3 \left(\int_0^1 y dy \right) dx = \frac{1}{2} \int_0^1 x^3 dx = \frac{1}{2} \cdot \frac{1}{4} = \frac{1}{8}. \end{aligned}$$

Let us also compute I_{Ox} for the rectangle of figure Fig.2. Whenever we have no density function given, we consider it to be the constant function $f(x, y) = 1$.

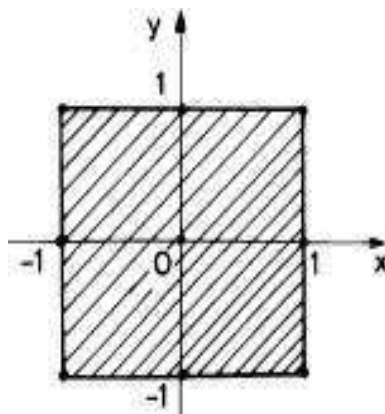

FIGURE 2

Thus we have:

$$I_{Ox} = \iint_D y^2 dx dy = \int_{-1}^1 y^2 \left(\int_{-1}^1 dx \right) dy = 2 \frac{y^3}{3} \Big|_{-1}^1 = \frac{4}{3}.$$

EXAMPLE 75. We also can compute the volume of some type of 3D-domaine called rectangular cylindrical solids. In Fig.3

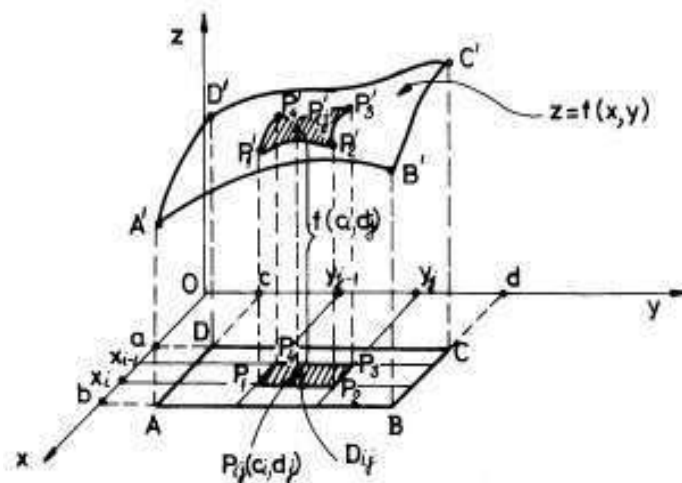

FIGURE 3

we have a cylindrical surface with its directrix curve the rectangle $[ABCD]$ in the xOy -plane and the generating lines parallel to the Oz -axis. We are interested to compute the volume of the solid Ω bounded by this cylindrical surface, by xOy -plane and by the surface $z = f(x, y) \geq 0$, i.e. the piece of this surface, $[A'B'C'D']$. Let us divide the basic rectangle $[ABCD]$ into small subdomains $D_{ij} = [x_{i-1}, x_i] \times [y_{j-1}, y_j] = [P_1P_2P_3P_4]$ and let us choose an arbitrary marking point $P_{ij}(c_i, d_j)$ in each D_{ij} , $i = 1, 2, \dots, n$ and $j = 1, 2, \dots, m$. The volume of the cylindrical solid which has as a basis the rectangle $[P_1P_2P_3P_4]$ and as a "hat" the piece $[P'_1P'_2P'_3P'_4]$ of the surface $z = f(x, y)$ can be well approximated (when the area of D_{ij} goes to 0) with the volume of a parallelepiped with the basis the same rectangle $[P_1P_2P_3P_4]$ and the height $f(c_i, d_j)$, i.e. the entire volume of our rectangular cylindrical solid can be well approximated with double Riemann sums of the form:

$$\sum_{i=1}^n \sum_{j=1}^m f(c_i, d_j)(y_j - y_{j-1})(x_i - x_{i-1}),$$

i.e. this last volume can be computed with the formula:

$$\text{vol} = \iint_{\Omega} f(x, y) dx dy.$$

When $f(x, y)$ has also negative values, we can use the more general formula:

$$(1.10) \quad \text{vol} = \iint_{\Omega} |f(x, y)| \, dx dy.$$

For instance, in Fig.4 we have a rectangular cylindrical body $[ABCOA'B'C'O']$. In this case the parallelepiped solid with the basis the rectangle $[ABCO]$ is cuted by the plane $\frac{x}{a} + \frac{y}{b} + \frac{z}{c} = 1$ in the upper part. Hence $z = c \left(1 - \frac{x}{a} - \frac{y}{b}\right)$, $a > 1$, $b > 1$ and the volume of our cylindrical body $[ABCOA'B'C'O']$ can be computed as follows:

$$\begin{aligned} \text{vol} &= \int_0^1 \left(\int_0^1 \left[c - \frac{c}{a}x - \frac{c}{b}y \right] dy \right) dx = \int_0^1 \left[cy - \frac{c}{a}xy - \frac{c}{2b}y^2 \right] \Big|_0^1 dx = \\ &= \int_0^1 \left(c - \frac{c}{a}x - \frac{c}{2b} \right) dx = \left(cx - \frac{c}{2a}x^2 - \frac{c}{2b}x \right) \Big|_0^1 = c - \frac{c}{2a} - \frac{c}{2b}. \end{aligned}$$

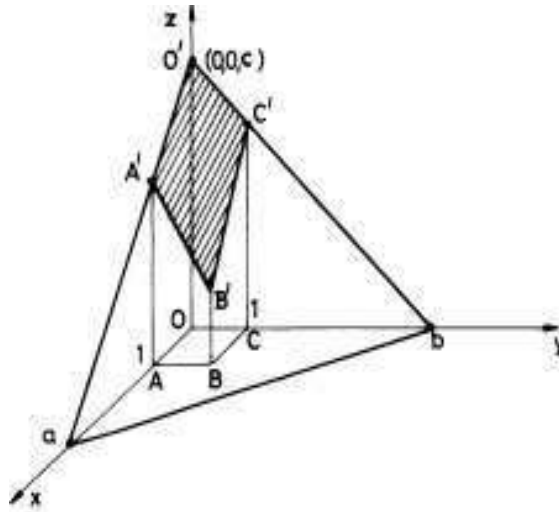

FIGURE 4

2. Double integrals on an arbitrary bounded domain

All the plane domains (connected subsets of \mathbb{R}^2) which we work with in the following are closed ($\partial D \subset D$) bounded and with a finite area $\sigma(D)$. This last general condition is not so easy to be verified in practice. Since in engineering one needs only closed bounded domains D with a piecewise smooth boundary ∂D , we shall limit our study for such domains. It is not difficult to prove (see the beginning considerations

in the chapter with line integrals) that a piecewise smooth boundary (a finite union of nonoverlapping smooth curves) can be well and uniformly approximated by polygonal lines. Hence the area of D can be represented as a limit of areas of figures bounded by polygonal lines. Since such a figure can be divided into a union of nonoverlapping triangles and since a triangle can be well approximated with simple rectangles (do it! or look in [Pal]), we finally deduce that any closed bounded domain D with a piecewise smooth boundary ∂D has an area (measure) $\sigma(D)$ (see definition 7) and this area is a limit of areas of elementary figures (finite union of nonoverlapping simple rectangles). Hence, it is natural to extend the definition of the double integral on a simple rectangle to an elementary figure $E = \cup_{i=1}^N D_i$, where $D_i = [a_i, b_i] \times [c_i, d_i]$, $D_i \cap D_j = \emptyset$ or a subset in \mathbb{R}^2 without interior points (points, segments of smooth lines, etc.), $i \neq j$, by the following formula:

$$\iint_E f(x, y) dx dy = \sum_{i=1}^N \iint_{D_i} f(x, y) dx dy.$$

A "theoretical" idea is to continue to extend the definition of the double integral to a closed bounded domain D with piecewise smooth ∂D ($\Rightarrow \text{area}(\partial D) = 0$), which can be well approximated from inside and from outside with two sequences $E_{ins}^{(n)}$ and $E_{out}^{(n)}$ of elementary figures, by the following formula:

$$\iint_D f(x, y) dx dy = \lim_{n \rightarrow \infty} \iint_{E_{ins}^{(n)}} f(x, y) dx dy = \lim_{n \rightarrow \infty} \iint_{E_{out}^{(n)}} f(x, y) dx dy.$$

Here $E_{ins}^{(n)} \subset D \subset E_{out}^{(n)}$, and $\lim_{n \rightarrow \infty} \sigma(E_{ins}^{(n)}) = \sigma(D) = \lim_{n \rightarrow \infty} \sigma(E_{out}^{(n)})$. Practically this definition can not be used at all! Thus, we shall use our previous experience to take again the definition of the double integral on the class of plane domains D just mentioned above. By $\text{diam}(D)$, the *diameter* of a bounded domain D , we mean the following number:

$$\text{diam}(D) = \sup \left\{ \left\| \overrightarrow{MM'} \right\| : M, M' \in D \right\}.$$

For instance, the diameter of a closed disc $B[A, r]$ is $2r$, i.e. its usual diameter. The diameter of a rectangle Ω is equal to the length of one of its diagonal. The diameter of a parallelogram is equal to the length of its greatest diagonal. And so on! A *division* Δ of the domain D (like above!) is a finite set of domains D_i , $i = 1, 2, \dots, n$, of the same type like D , such that $\cup D_i = D$ and $D_i \cap D_j = \emptyset$ or a figure of zero area (in fact points or piecewise smooth curves!) for $i \neq j$ (see

Fig.5). The *norm* of a division Δ is the following nonnegative real number: $\|\Delta\| = \max\{\text{diam}(D_i) : i = 1, 2, \dots, n\}$. A *set of marking points* $\{P_i(c_i, d_i)\}$, $i = 1, 2, \dots, n$ for a division Δ is a set of some fixed points $P_i(c_i, d_i) \in D_i$ for any $i = 1, 2, \dots, n$. For a function $f : D \rightarrow \mathbb{R}$, for a division Δ of D and for a set of marking points $\{P_i(c_i, d_i)\}$ we define the corresponding Riemann sum:

$$(2.1) \quad S_f(\Delta, \{P_i(c_i, d_i)\}) = \sum_{i=1}^n f((c_i, d_i)) \text{area}(D_i).$$

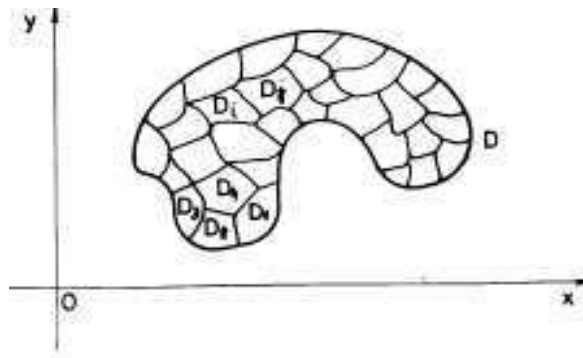

FIGURE 5

DEFINITION 24. A function $f : D \rightarrow \mathbb{R}$ is (Riemann) integrable on D if there exists a real number I (denoted by $\iint_D f(x, y) dx dy$) such that for any small $\varepsilon > 0$, there exists a small δ (depending on ε) with the following property: if Δ is a division of D with $\|\Delta\| < \delta$, then $|I - S_f(\Delta, \{P_i(c_i, d_i)\})| < \varepsilon$ for any set of marking points $\{P_i(c_i, d_i)\}$ of Δ . This means that we can well approximate the number I with Riemann sums of the form $S_f(\Delta, \{P_i(c_i, d_i)\})$, when $\|\Delta\| \rightarrow 0$.

We shall state without a proof some results which are analogous with the corresponding results for the simple Riemann integral introduced and studied in chapter II. It will not be so difficult for the reader to imitate the proofs given there. If some difficulties will appear, look in [Pal] for complete proofs.

THEOREM 75. Let D be a plane domain like above and let $f : D \rightarrow \mathbb{R}$ be a Riemann integrable function. Then f must be bounded.

This last result says that the class of integrable functions is included in the class of bounded functions. This is why any function considered by us in the following is assumed to be bounded.

Let D be like above, let $\Delta = \{D_i\}$, $i = 1, 2, \dots, n$ be a division of D and let f be a bounded function defined on D with values in \mathbb{R} . Let $m_i = \inf\{f(x, y) : (x, y) \in D_i\}$ and let $M_i = \sup\{f(x, y) : (x, y) \in D_i\}$ for any $i = 1, 2, \dots, n$. Then

$$s_{\Delta}(f) = \sum_{i=1}^n m_i \cdot \text{area}(D_i)$$

is called the *inferior Darboux sum* of f relative to Δ and

$$S_{\Delta}(f) = \sum_{i=1}^n M_i \cdot \text{area}(D_i)$$

is said to be the *superior Darboux sum* of f relative to Δ . It is clear that

$$m \cdot \text{area}(D) \leq s_{\Delta}(f) \leq S_{\Delta}(f) \leq M \cdot \text{area}(D),$$

for any set of marking points $\{P_i(c_i, d_i)\}$ of the division Δ , where $m = \inf\{f(x, y) : (x, y) \in D\}$ and $M = \sup\{f(x, y) : (x, y) \in D\}$. Since the set $\{s_{\Delta}(f) : \Delta \text{ goes on the set of all divisions of } D\}$ is upper bounded by $M \cdot \text{area}(D)$, it has a least upper bound $I_*(f)$. Since the set $\{S_{\Delta}(f) : \Delta \text{ goes on the set of all divisions of } D\}$ is lower bounded by $m \cdot \text{area}(D)$, it has a greatest lower bound $I^*(f)$. In general, $I_*(f) \leq I^*(f)$.

THEOREM 76. (Darboux criterion) *Let D be like above and let $f : D \rightarrow \mathbb{R}$ be a bounded function. Then f is integrable on D if and only if $I_*(f) = I^*(f)$, i.e. if and only if for any $\varepsilon > 0$ there exists a $\delta_{\varepsilon} > 0$ such that if $\|\Delta\| < \delta_{\varepsilon}$ then $S_{\Delta}(f) - s_{\Delta}(f) < \varepsilon$. In this last case*

$$I_*(f) = I^*(f) = \iint_D f(x, y) dx dy.$$

This criterion is very useful whenever we want to prove that a specified class of functions is integrable.

THEOREM 77. *Let D be a closed bounded plane domain with ∂D a piecewise smooth curve and let $f : D \rightarrow \mathbb{R}$ be a continuous function defined on D . Then f is integrable on D . If f is continuous on a subset $D \setminus A$ of D such that A has an area equal to zero, then f is also integrable on D .*

PROOF. We prove only the first statement of the theorem. Since D is closed and bounded, D is a compact subset of \mathbb{R}^2 . Since f is

continuous, it is uniformly continuous (see [Po], theorem 59). In order to prove that f is integrable we shall use the above Darboux criterion (see theorem 76). For this, let us take a small $\varepsilon > 0$. The uniform continuity of f implies that there exists a small $\delta > 0$ (depending on ε) such that if $\mathbf{x}, \mathbf{x}' \in D$ and $\|\mathbf{x} - \mathbf{x}'\| < \delta$, then $|f(\mathbf{x}) - f(\mathbf{x}')| < \frac{\varepsilon}{\text{area}(D)}$. Let us take a division $\Delta = \{D_i\}$, $i = 1, 2, \dots, n$ of D with $\|\Delta\| < \delta$. Since each D_i is a compact subset of \mathbb{R}^2 and since f is continuous, there exist $\mathbf{x}^{(i)}$ and $\mathbf{x}'^{(i)}$ in D_i with

$$m_i = \inf\{f(x, y) : (x, y) \in D_i\} = f(\mathbf{x}^{(i)})$$

and

$$M_i = \sup\{f(x, y) : (x, y) \in D_i\} = f(\mathbf{x}'^{(i)})$$

(see [Po], theorem 58). Hence

$$\begin{aligned} S_\Delta(f) - s_\Delta(f) &= \sum_{i=1}^n [f(\mathbf{x}'^{(i)}) - f(\mathbf{x}^{(i)})] \cdot \text{area}(D_i) \leq \\ &\leq \sum_{i=1}^n |f(\mathbf{x}'^{(i)}) - f(\mathbf{x}^{(i)})| \cdot \text{area}(D_i) < \frac{\varepsilon}{\text{area}(D)} \sum_{i=1}^n \text{area}(D_i) = \varepsilon, \end{aligned}$$

because $\|\Delta\| < \delta$ implies $\text{diam}(D_i) < \delta$ and so, $\|\mathbf{x}'^{(i)} - \mathbf{x}^{(i)}\| < \delta$. Thus we can apply the uniform continuity of f and finally we get that $S_\Delta(f) - s_\Delta(f) < \varepsilon$, i.e. that f is integrable. \square

REMARK 27. Up to now we used closed bounded domains D_i with piecewise smooth boundaries, as subdomains of a division Δ of a fixed domain D of the same type. Since any such subdomain D_i can be well approximated with elementary figures (finite union of nonoverlapping simple rectangles) or with finite unions of nonoverlapping triangles, discs, parallelograms, etc., we can substitute these D_i in definition 24 or in theorem 76 with triangles, discs, parallelograms, etc. It is clear that in general it is not possible to cover a domain D with nonoverlapping discs, for instance. But, for any small $\varepsilon > 0$, there exists such a union of discs $U_\varepsilon \subset D$, such that $\text{area}(D \setminus U_\varepsilon) < \varepsilon$. Hence we can work with the following alternative equivalent definition for an integrable function f . We say that $f : D \rightarrow \mathbb{R}$ is (Riemann) integrable on D if there exists a real number I such that for any small $\varepsilon > 0$ and $\eta > 0$ there exists a union $U_\eta = \{B_i\}$ of nonoverlapping discs, such that $U_\eta \subset D$, $\text{area}(D \setminus U_\eta) < \eta$ and $|I - \sum_{i=1}^n f((c_i, d_i)) \text{area}(B_i)| < \varepsilon$ for any set of marking points $\{P_i(c_i, d_i)\}$, $P_i(c_i, d_i) \in B_i$, $i = 1, 2, \dots, n$. Similarly we can work with triangles, parallelograms, general rectangles, etc., instead of discs.

The following result put together some basic properties of the double integral.

THEOREM 78. a) the mapping $f \rightsquigarrow \iint_D f(x, y) dx dy$ is a linear mapping defined on the vector space $\text{Int}(D)$ of all integrable functions defined on D . This means that

$$\iint_D [\alpha f(x, y) + \beta g(x, y)] dx dy = \alpha \iint_D f(x, y) dx dy + \beta \iint_D g(x, y) dx dy.$$

b) the mass of a lamina (D, f) can be computed as follows:

$$\text{mass}(D) = \iint_D f(x, y) dx dy.$$

In particular the area of D is equal to $\iint_D dx dy$.

c) if $f \leq g$ on D , then $\iint_D f(x, y) dx dy \leq \iint_D g(x, y) dx dy$. In particular, if $f \geq 0$ on D , then $\iint_D f(x, y) dx dy \geq 0$.

$$d) \left| \iint_D f(x, y) dx dy \right| \leq \iint_D |f(x, y)| dx dy.$$

e) $\iint_D f(x, y) dx dy = f(x_0, y_0) \cdot \text{area}(D)$, where f is continuous and (x_0, y_0) is a point of D (the mean formula). This formula says that any nonhomogeneous plate has the same mass as a homogenous plate with the same domain D and the constant density equal to the value of the initial density function at a certain point of D . In particular, if f is continuous, $f(x, y) \geq 0$ and $\iint_D f(x, y) dx dy > 0$, then f is not zero at least on a small disc contained in D . Moreover, if $f \geq 0$ and $\iint_D f(x, y) dx dy = 0$, then the set A of points (x, y) for which $f(x, y) > 0$ has area equal to zero (the proof of this statement is more difficult).

f) if $\Delta = \{D_i\}$, $i = 1, 2, \dots, n$ is a division of D , then

$$\iint_D f(x, y) dx dy = \sum_{i=1}^n \iint_{D_i} f(x, y) dx dy.$$

Since we have no effective method to compute a double integral up to the present time, we postpone the work with some examples. Thus we continue our study by presenting a basic method for computing double integrals, namely the "iterative method". The name comes from the fact that by using this method we shall reduce the computation of a double integral to the successive (iterative) calculation of two simple Riemann integrals. We begin with some prerequisites.

We say that a domain D like above (closed, bounded and ∂D is a piecewise smooth curve) is *simple w.r.t. Ox -axis* if any straight line $x = x_0$, parallel to Oy -axis, $x \in (a, b)$, where $[a, b] = pr_{Ox}(D)$, intersects the boundary ∂D in one or two distinct points (see Fig.6). The reader can easily observe that the domain D from Fig.6 is also simple w.r.t. Oy -axis. Let $[c, d] = pr_{Oy}(D)$ and let $\Omega = [a, b] \times [c, d] = [LMNP]$ be "the least" simple rectangle which contains D (see Fig.6). We write the boundary ∂D as a union of two arcs: $\partial D = [\widehat{ABUC}] \cup [\widehat{CEVA}]$. Assume that a parametrization of $[\widehat{ABUC}]$ is: $\begin{cases} x = x, & x \in [a, b] \\ y = \alpha(x) \end{cases}$, a parametrization of $[\widehat{CEVA}]$ is: $\begin{cases} x = x, & x \in [a, b] \\ y = \beta(x) \end{cases}$ and that $\alpha(x) \leq \beta(x)$ for any $x \in [a, b]$.

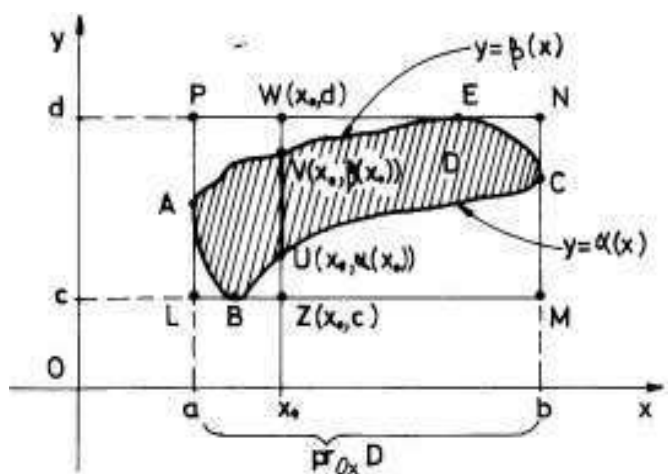

FIGURE 6

With these notation and definitions one has the following basic result.

THEOREM 79. (*iterative general formula*) *Let D be a simple domain w.r.t. Ox -axis like above and let $f : D \rightarrow \mathbb{R}$ be a piecewise continuous function (bounded and continuous on D except a subset of zero area) defined on D . Then*

$$(2.2) \quad \iint_D f(x, y) dx dy = \int_a^b \left(\int_{\alpha(x)}^{\beta(x)} f(x, y) dy \right) dx.$$

Here $I(x) = \int_{\alpha(x)}^{\beta(x)} f(x, y) dy$ is an integral with a parameter x in its general form (see formula (1.2)). This formula says that in order to compute a double integral on this particular type of domain D , we fix an x on $[a, b]$, the projection of D on Ox -axis, cut the domain D with the vertical line which passes through x and obtain the segment $[UV]$, where $U(x, \alpha(x))$ and $V(x, \beta(x))$, compute the simple integral $I(x) = \int_{\alpha(x)}^{\beta(x)} f(x, y) dy$ with a parameter x , along this segment and finally compute the next simple integral $\int_a^b I(x) dx$. In fact, we just computed the mass $I(x)$ of the segment $[UV]$, which depends on x , then we "made the sum" $\int_a^b I(x) dx$ of all these masses $I(x)$.

PROOF. We intend to use the similar iterative formula for a rectangle (see formula (1.2)) for an extension-function $\tilde{f}(x, y) : \Omega = [LMNP] \rightarrow \mathbb{R}$ of $f : D \rightarrow \mathbb{R}$ to Ω . We simply extend f from D to the rectangle $\Omega = [a, b] \times [c, d]$ by putting zero in all the points of $\Omega \setminus D$:

$$\tilde{f}(x, y) = \begin{cases} f(x, y), & \text{if } (x, y) \in D \\ 0, & \text{if } (x, y) \in \Omega \setminus D \end{cases}.$$

Since this function is continuous on Ω except maybe the points of ∂D , which has zero area, we can apply theorem 77 and find that \tilde{f} is integrable on Ω and

$$\iint_D f(x, y) dx dy = \iint_{\Omega} \tilde{f}(x, y) dx dy - \iint_{\Omega \setminus D} 0 \cdot dx dy = \iint_{\Omega} \tilde{f}(x, y) dx dy.$$

But now we can apply the iterative formula (1.2) for the rectangle $\Omega = [a, b] \times [c, d]$ and find:

$$\iint_{\Omega} \tilde{f}(x, y) dx dy = \int_a^b \left(\int_c^d \tilde{f}(x, y) dy \right) dx =$$

$$\begin{aligned}
&= \int_a^b \left(\int_c^{\alpha(x)} \tilde{f}(x, y) dy + \int_{\alpha(x)}^{\beta(x)} \tilde{f}(x, y) dy + \int_{\beta(x)}^d \tilde{f}(x, y) dy \right) dx = \\
&= \int_a^b \left(\int_{\alpha(x)}^{\beta(x)} f(x, y) dy \right) dx.
\end{aligned}$$

□

For instance, let us compute the mass of the plate D with the density function $f(x, y) = 3xy^2$, where D is the domain bounded by the line $y = x$ and the parabola $y = x^2$. Since $x \in [0, 1]$ and since $x \geq x^2$, when $x \in [0, 1]$, we get:

$$\begin{aligned}
mass(D) &= \iint_D 3xy^2 dx dy = \int_0^1 x \left(\int_{x^2}^x 3y^2 dy \right) dx = \int_0^1 x \cdot y^3 \Big|_{x^2}^x dx = \\
&= \int_0^1 x \cdot (x^3 - x^6) dx = \frac{x^5}{5} - \frac{x^8}{8} \Big|_0^1 = \frac{1}{5} - \frac{1}{8} = \frac{3}{40}.
\end{aligned}$$

REMARK 28. If the domain D is not simple w.r.t. Ox -axis but it is simple w.r.t. Oy -axis (see Fig.7) we obtain the analogous formula:

$$(2.3) \quad \iint_D f(x, y) dx dy = \int_c^d \left(\int_{\delta(y)}^{\gamma(y)} f(x, y) dx \right) dy,$$

where $x = \delta(y)$, $y = y$ is the parametrization of the arc $[XW_4SGmY]$ and $x = \gamma(y)$, $y = y$ is the parametrization of the arc $[YW_1TW_2nHW_3X]$ (Prove this last formula!).

Let for instance the domain D bounded by the following curves: $x = y^2 + 1$, $x = 1$, and $x = 5$. Let us compute the coordinates of its mass centre $G(x_G, y_G)$. Whenever one gives us no density function, this means that the plate D is tacitly considered to be homogenous with the constant density 1. Moreover, D is symmetric w.r.t. Ox -axis, so that $y_G = 0$ (prove it by pure calculation!). Since a double integral on a general domain D like above can be well approximated by sums of double integrals on simple rectangles, all the formulas from (1.7) and (1.8) can be used for our nonrectangular domain D . Hence, we need to compute two double integrals:

$$mass(D) = area(D) = \iint_D dx dy = 2 \int_1^5 \left(\int_0^{\sqrt{x-1}} dy \right) dx =$$

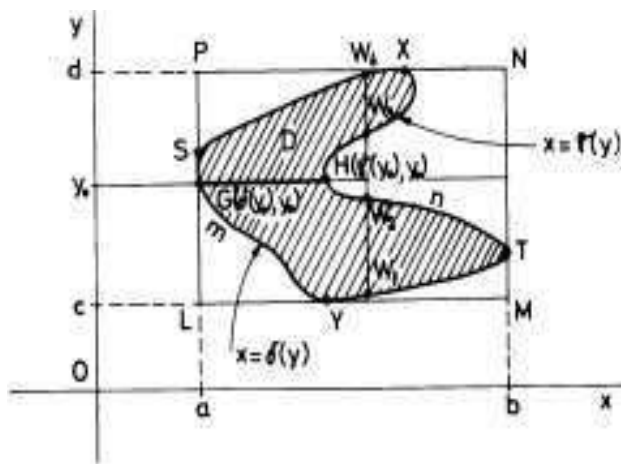

FIGURE 7

$$= 2 \int_1^5 \sqrt{x-1} dx = 2 \left. \frac{(x-1)^{\frac{3}{2}}}{\frac{3}{2}} \right|_1^5 = \frac{4}{3} \cdot 4^{\frac{3}{2}} = \frac{32}{3}.$$

Let us compute now the static moment w.r.t. Oy -axis, by using formula (2.3) (decomposing D into two nonoverlapping subdomains, compute also this moment by using formula (2.2)):

$$\begin{aligned} M_{Oy}(D) &= \iint_D x dx dy = \int_{-2}^2 \left(\int_1^{y^2+1} x dx \right) dy = \\ &= \frac{1}{2} \int_{-2}^2 [(y^2+1)^2 - 1] dy = \int_0^2 [y^4 + 2y^2] dy = \frac{2^4 \cdot 11}{15}. \end{aligned}$$

Thus,

$$x_G = \frac{\iint_D x dx dy}{\text{mass}(D)} = \frac{\frac{2^4 \cdot 11}{15}}{\frac{32}{3}} = \frac{33}{30}.$$

Prove that this x_G is the same like the x -coordinates of the mass centre of the domain D' bounded by $y = 2$, $x = y^2 + 1$ and by $x = 1$.

Let us now compute the moment of inertia $I_{Ox}(D)$ of the plate D from Fig.8 with the density function $f(x, y) = 2x$. The formula is the same formula for rectangles (see formula (1.8)) extended to a general

domain D (one can deduce this formula directly. Do it!):

$$\begin{aligned} I_{Ox}(D) &= \iint_D y^2 f(x, y) dx dy = \iint_D 2xy^2 dx dy = \\ &= \int_0^2 2x \left(\int_{x^2}^{2\sqrt{2}x} y^2 dy \right) dx = \\ &= \frac{2}{3} \int_0^2 (16\sqrt{2}x^{\frac{3}{2}} - x^6) dx = \frac{2}{3} \left[\frac{32\sqrt{2}}{5} x^{\frac{5}{2}} - \frac{x^7}{7} \right] \Big|_0^2 = \frac{768}{35}. \end{aligned}$$

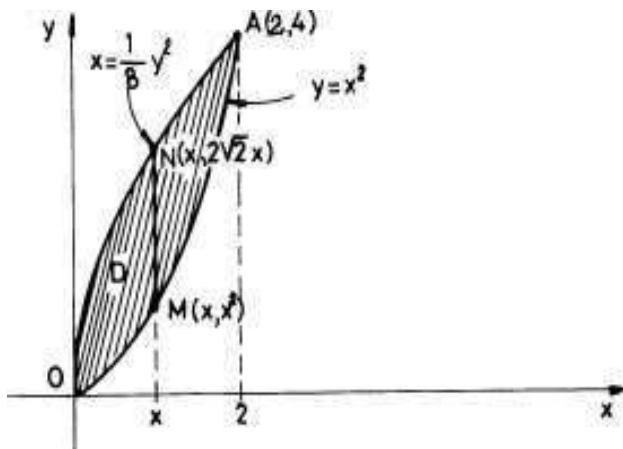

FIGURE 8

In example 75 we deduced a formula (1.10) to compute the volume of a cylindrical solid bounded by a rectangular domain D and "above" by a piece of a surface $z = f(x, y)$. The same type of reasoning can be extended for a general domain D like above and the formula remains the

same: $vol = \iint_D |f(x, y)| dx dy$. Let us apply this formula to compute

the volume of the cylindrical solid (generated by lines parallel to Oz -axis) with the basis the domain D bounded by the coordinate axes Ox , Oy , and the line $x + y = 1$, and limited "above" by the surface $z = x^2 + y^2$. Hence

$$vol = \iint_D (x^2 + y^2) dx dy = \int_0^1 \left(\int_0^{1-x} (x^2 + y^2) dy \right) dx =$$

$$\int_0^1 \left(x^2 y + \frac{y^3}{3} \Big|_0^{1-x} \right) dx = \int_0^1 \left(x^2(1-x) + \frac{(1-x)^3}{3} \right) dx =$$

$$\left[\frac{x^3}{3} - \frac{x^4}{4} - \frac{(1-x)^4}{12} \right] \Big|_0^1 = \frac{1}{3} - \frac{1}{4} + \frac{1}{12} = \frac{1}{6}.$$

EXERCISE 8. Let D be a simple domain w.r.t. Ox -axis and let $[a, b]$ be its projection on Ox -axis. For any $x \in [a, b]$ let $M_x(x, \alpha(x))$ and $N_x(x, \beta(x))$, $\alpha(x) \leq \beta(x)$ be the points at which the vertical line $X = x$ cuts ∂D , the boundary of D . Let $G(x, \theta(x))$ be the mass centre (the density function is 1) of the segment $[M_x N_x]$. Let (γ, f) be the wire $x = x$, $y = \theta(x)$, and $f(x, \theta(x)) = \text{length}[M_x N_x]$, where $x \in [a, b]$ and let H be its mass centre. Prove that H is the mass centre of D .

EXERCISE 9. State and comment a Lebesgue type criterion for double integrals.

EXERCISE 10. Let $f, g : D \rightarrow \mathbb{R}$ be two piecewise continuous functions defined on a domain D like above. Let $A = \{(x, y) \in D : f(x, y) \neq g(x, y)\}$. We assume that A has zero area. Prove that

$$\iint_D f(x, y) dx dy = \iint_D g(x, y) dx dy.$$

3. Green formula. Applications.

The following formula connects a line integral of the second type with a double integral. Such formulas are important because one can reduce the computations from a dimension to an inferior one.

THEOREM 80. (Green formula) Let D be a closed bounded domain with ∂D a direct oriented (trigonometric direction) piecewise smooth and "closed" curve. We also assume that the domain D is simple w.r.t. both axes. Let $\vec{F}(x, y) = P(x, y) \vec{i} + Q(x, y) \vec{j}$ be a plane field of class C^1 defined on D . Then

$$(3.1) \quad \oint_{\partial D} P dx + Q dy = \iint_D \left(\frac{\partial Q}{\partial x} - \frac{\partial P}{\partial y} \right) dx dy.$$

This formula is called the Green formula.

PROOF. In Fig.9

we assume the following parametrizations:

$$(3.2) \quad \text{arc}[ACB] : \begin{cases} x = x \\ y = \varphi(x) \end{cases}, x \in [a, b],$$

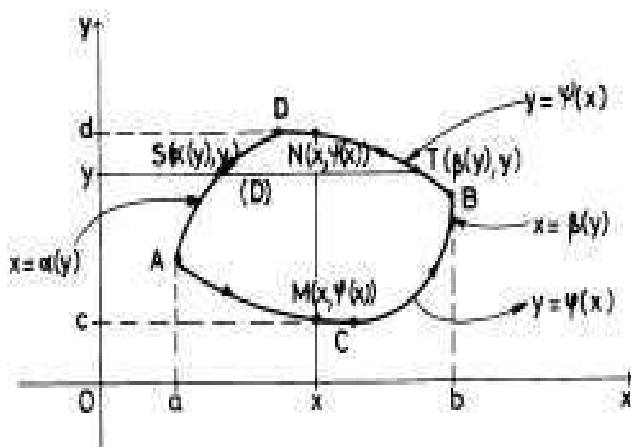

FIGURE 9

$$(3.3) \quad \text{arc}[BDA] : \begin{cases} x = x \\ y = \psi(x) \end{cases}, x \in [a, b]^{-},$$

$$(3.4) \quad \text{arc}[DAC] : \begin{cases} x = \alpha(y) \\ y = y \end{cases}, y \in [c, d]^{-},$$

$$(3.5) \quad \text{arc}[CBD] : \begin{cases} x = \beta(y) \\ y = y \end{cases}, y \in [c, d].$$

a) We firstly prove that $-\iint_D \frac{\partial P}{\partial y} dx dy = \oint_{\partial D} P dx$. Indeed,

$$\begin{aligned} -\iint_D \frac{\partial P}{\partial y} dx dy &= -\int_a^b \left(\int_{\varphi(x)}^{\psi(x)} \frac{\partial P}{\partial y}(x, y) dy \right) dx = \\ &= \int_a^b P(x, \varphi(x)) dx - \int_a^b P(x, \psi(x)) dx = \\ &= \oint_{\text{arc}[ACB]} P dx + \oint_{\text{arc}[BDA]} P dx = \oint_{\partial D} P dx. \end{aligned}$$

b) We prove now that $\iint_D \frac{\partial Q}{\partial x} dx dy = \oint_{\partial D} Q dy$. Indeed,

$$\iint_D \frac{\partial Q}{\partial x} dx dy = \int_c^d \left(\int_{\alpha(y)}^{\beta(y)} \frac{\partial Q}{\partial x}(x, y) dx \right) dy =$$

$$\int_c^d Q(\beta(y), y)dy - \int_c^d Q(\alpha(y), y)dy =$$

$$\oint_{\text{arc}[CBD]} Qdy + \oint_{\text{arc}[DAC]} Qdy = \oint_{\partial D} Qdy.$$

We now add the two equalities obtained in a) and b) and we finally get the Green formula. \square

REMARK 29. If our domain D is not simple with respect to one axis or to both, we break it into a finite number of subdomains which are simple w.r.t. both axis and they preserve the other properties of D . Then we apply Green formula for each of these last domains. Let us do this for the domain D of Fig.10,

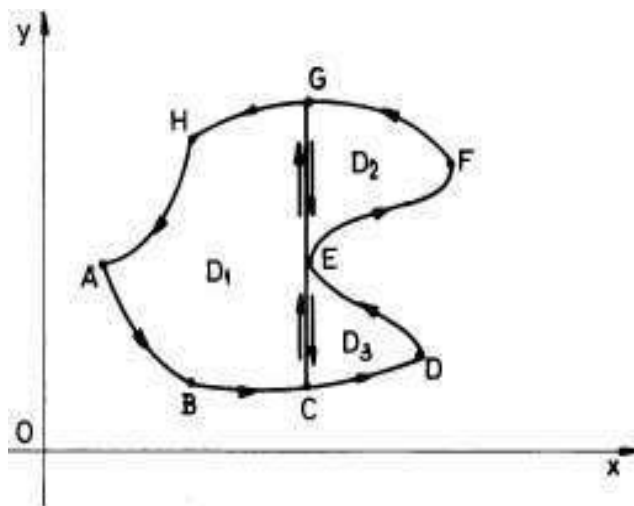

FIGURE 10

bounded by the arc $[ABCDEFGHGA]$:

$$\iint_D \left(\frac{\partial Q}{\partial x} - \frac{\partial P}{\partial y} \right) dx dy = \iint_{D_1} \left(\frac{\partial Q}{\partial x} - \frac{\partial P}{\partial y} \right) dx dy +$$

$$+ \iint_{D_2} \left(\frac{\partial Q}{\partial x} - \frac{\partial P}{\partial y} \right) dx dy + \iint_{D_3} \left(\frac{\partial Q}{\partial x} - \frac{\partial P}{\partial y} \right) dx dy =$$

$$\stackrel{\text{Green}}{=} \oint_{\text{arc}[GHABCEG]} Pdx + Qdy + \oint_{\text{arc}[EFGE]} Pdx + Qdy + \oint_{\text{arc}[CDEC]} Pdx + Qdy =$$

$$\begin{aligned}
&= \oint_{\text{arc}[GHABC]} Pdx + Qdy + \oint_{\text{arc}[CE]} Pdx + Qdy + \oint_{\text{arc}[EG]} Pdx + Qdy + \\
(3.6) \quad &+ \oint_{\text{arc}[EFG]} Pdx + Qdy + \oint_{\text{arc}[GE]} Pdx + Qdy + \\
&+ \oint_{\text{arc}[CDE]} Pdx + Qdy + \oint_{\text{arc}[EC]} Pdx + Qdy.
\end{aligned}$$

Since $\oint_{\text{arc}[CE]} Pdx + Qdy + \oint_{\text{arc}[EC]} Pdx + Qdy = 0$ and $\oint_{\text{arc}[EG]} Pdx + Qdy + \oint_{\text{arc}[GE]} Pdx + Qdy = 0$, in formula (3.6) it remains

$$\begin{aligned}
\iint_D \left(\frac{\partial Q}{\partial x} - \frac{\partial P}{\partial y} \right) dxdy &= \oint_{\text{arc}[GHABC]} Pdx + Qdy + \oint_{\text{arc}[CDE]} Pdx + Qdy + \\
&+ \oint_{\text{arc}[EFG]} Pdx + Qdy = \oint_{\partial D} Pdx + Qdy,
\end{aligned}$$

i.e. we obtained the Green formula for the domain D .

EXAMPLE 76. (formulas for areas again). Let us put in theorem 80 or in remark 29 $Q(x, y) = x$ and $P(x, y) = -y$. We get again the known formula for the computation of an area by using line integrals of the second type:

$$\text{area}(D) = \iint_D dxdy = \frac{1}{2} \oint_{\partial D} xdy - ydx.$$

If we put now $Q(x, y) = x$ and $P(x, y) = 0$, we get

$$\text{area}(D) = \iint_D dxdy = \oint_{\partial D} xdy.$$

If we put $P(x, y) = -y$ and $Q(x, y) = 0$, we get

$$\text{area}(D) = \iint_D dxdy = - \oint_{\partial D} ydx.$$

EXAMPLE 77. Let in addition D be a simple connected domain. Then the condition $\frac{\partial Q}{\partial x} = \frac{\partial P}{\partial y}$ implies the fact that the line integral

$\oint_{\text{arc}[AB]} Pdx + Qdy$ depends only on the points A and B but not on the

geometrical form of the arc $[AB]$ which connect these points A and B . Indeed, if we take a direct oriented closed piecewise smooth curve $\gamma \subset D$ and if we denote by $D_\gamma \subset D$ the subdomain of D bounded by γ (here we need that D be simple connected), by applying Green formula for D_γ with $\partial D_\gamma = \gamma$, we get:

$$\oint_{\gamma} Pdx + Qdy = \iint_{D_\gamma} \left(\frac{\partial Q}{\partial x} - \frac{\partial P}{\partial y} \right) dxdy = 0.$$

Thus, from remark 26 we get that $\oint_{\text{arc}[AB]} Pdx + Qdy$ is independent on

the path which connect A and B and, consequently, the field $\vec{F} = (P, Q)$ is conservative.

EXAMPLE 78. (a practical method for computing the static moments for plane domains) In Mechanics we meet the following situation. Let D be a plane domain with a complicated boundary ∂D . Moreover, we do not know exactly to describe this boundary; it is only supplied by a large number of points

$$A_0(x_0, y_0), A_1(x_1, y_1), \dots, A_n(x_n, y_n)$$

which are situated on ∂D (see Fig.11).

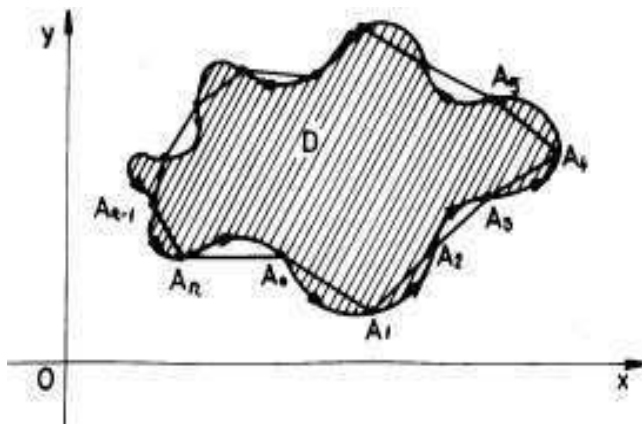

FIGURE 11

Assume that we have to compute the k -th static moment of D w.r.t. Oy -axis, $k = 0, 1, 2, \dots$, i.e. the number $\iint_D x^k dx dy$. But, since for $Q(x, y) = \frac{x^{k+1}}{k+1}$, $\frac{\partial Q}{\partial x} = x^k$, we can take $Q(x, y) = \frac{x^{k+1}}{k+1}$ and $P = 0$ in the Green formula:

$$\iint_D x^k dx dy = \oint_{\partial D} \frac{x^{k+1}}{k+1} dy.$$

If n is large enough and if the lengths $\|\overrightarrow{A_j A_{j+1}}\|$ are small enough, we can well approximate ∂D with the polygonal line $[A_0 A_1 \dots A_{n-1} A_n A_0]$. Thus

$$(3.7) \quad \iint_D x^k dx dy = \oint_{\partial D} \frac{x^{k+1}}{k+1} dy \approx$$

$$(3.8) \quad \approx \frac{1}{k+1} \left[\sum_{i=1}^n \oint_{[A_{i-1} A_i]} x^{k+1} dy \right] + \frac{1}{k+1} \oint_{[A_n A_0]} x^{k+1} dy.$$

Let us compute the line integral $\oint_{[A_{i-1} A_i]} x^{k+1} dy$. A natural parametrization of the direct oriented segment $[A_{i-1} A_i]$ is the following:

$$[A_{i-1} A_i] : \begin{cases} x = x_{i-1} + t(x_i - x_{i-1}) \\ y = y_{i-1} + t(y_i - y_{i-1}) \end{cases}, t \in [0, 1].$$

Thus

$$\begin{aligned} \oint_{[A_{i-1} A_i]} x^{k+1} dy &= \int_0^1 [x_{i-1} + t(x_i - x_{i-1})]^{k+1} (y_i - y_{i-1}) dt = \\ &= \frac{y_i - y_{i-1}}{x_i - x_{i-1}} \cdot \frac{1}{k+2} [x_{i-1} + t(x_i - x_{i-1})]^{k+2} \Big|_0^1 = \\ &= \frac{1}{k+2} (y_i - y_{i-1}) \frac{x_i^{k+2} - x_{i-1}^{k+2}}{x_i - x_{i-1}}. \end{aligned}$$

Hence

$$(3.9) \quad \iint_D x^k dx dy \approx$$

$$\approx \frac{1}{(k+1)(k+2)} \left[(y_0 - y_n) \frac{x_0^{k+2} - x_n^{k+2}}{x_0 - x_n} + \sum_{i=1}^n (y_i - y_{i-1}) \frac{x_i^{k+2} - x_{i-1}^{k+2}}{x_i - x_{i-1}} \right].$$

This last formula is important in practice. For instance, if D is bounded by a polygonal line $[A_0A_1\dots A_{n-1}A_nA_0]$ and if $k = 0$, we get

$$(3.10) \quad \text{area}(D) = \frac{1}{2} \left[(y_0 - y_n)(x_0 + x_n) + \sum_{i=1}^n (y_i - y_{i-1})(x_i + x_{i-1}) \right]$$

For instance, if $n = 2$ (a triangle), we get a known formula for computing the area of a triangle

$$\text{area}(\Delta A_0A_1A_2) = \frac{1}{2} \begin{vmatrix} x_0 & y_0 & 1 \\ x_1 & y_1 & 1 \\ x_2 & y_2 & 1 \end{vmatrix}.$$

Here we do not need to put the absolute value for the determinant because the direct trigonometric direction of the sequence of points A_0, A_1, A_2 assures the nonnegativity of this determinant. We propose to the reader to find nice geometrical or mechanical interpretations for formulas (3.9) and (3.10).

We can even continue to find "nice" formulas. Let the $m \times m$ matrix

$$\left(I_{ij}(D) = \iint_D x^i y^j f(x, y) dx dy \right)$$

of the generalized moment of inertia for a plate (D, f) , where f is the density function. If one can well approximate this f by a polynomial $P(x, y)$ in two variables, we can reduce the problem of the calculation of such moments to the computation of double integrals of the following

type $\iint_D x^i y^j dx dy$ for $i, j \in \{0, 1, 2, \dots\}$. Applying again Green formula we get

$$\iint_D x^i y^j dx dy = \oint_{\partial D} \frac{x^{i+1}}{i+1} y^j dy.$$

We leave as an exercise to the reader to compute this last integral for a domain D bounded by the above polygonal line $[A_0A_1\dots A_{n-1}A_nA_0]$ and to discuss the obtained formula.

4. CHANGE OF VARIABLES IN DOUBLE INTEGRALS. POLAR COORDINATES 251

EXAMPLE 79. Let us use the Green formula (see theorem 80) to compute the line integral $I = \oint_{\text{arc}[OABO]} xydx + x^2dy$ (see Fig.12). Thus,

$$I = \iint_D (2x - x) dx dy = \int_0^1 x \left(\int_x^{2x} dy \right) dx = \int_0^1 x^2 dx = \frac{1}{3}.$$

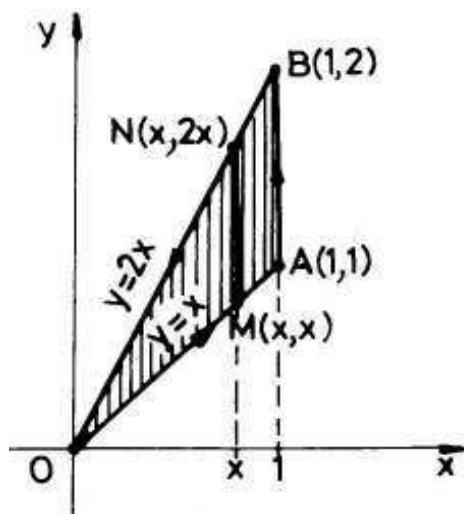

FIGURE 12

4. Change of variables in double integrals. Polar coordinates.

When we have to compute a double integral $\iint_D f(x,y) dx dy$ we need an analytical expression of f and a parameterization of the boundary ∂D of the domain D . It is clear that if these ones are complicated, our integral can not easily be computed.

EXAMPLE 80. For instance, let us try to find the mass of the disc $D = \{(x,y) : x^2 + y^2 \leq 9\}$ with the density function $f(x,y) = x^2 y^2$.

$$\text{mass}(D) = \iint_D x^2 y^2 dx dy = \int_{-3}^3 x^2 \left(\int_{-\sqrt{9-x^2}}^{\sqrt{9-x^2}} y^2 dy \right) dx =$$

$$= \frac{2}{3} \int_{-3}^3 x^2 y^3 \Big|_0^{\sqrt{9-x^2}} dx = \frac{2}{3} \int_{-3}^3 x^2 (9-x^2) \sqrt{9-x^2} dx.$$

But, to compute this last simple integral it is not so immediately. We shall see later that the best idea is to change the disc D with a rectangular domain because usually to integrate on rectangles is easier than to integrate on discs. Here is some theoretical support for this strong method of computing double integrals.

Let us start with a smooth (of class C^1) deformation (or a smooth parametrization sheet) $\vec{g} : \Omega \rightarrow D$ of a closed bounded plane domain Ω onto another closed bounded domain D ("onto" means that $\vec{g}(\Omega) = D$). We also assume that $\partial\Omega$ and ∂D are piecewise smooth curves (thus Ω and D have areas!) and that \vec{g} is a diffeomorphism on Ω , i.e. it is invertible and its inverse \vec{g}^{-1} is also smooth, i.e. of class C^1 on D . If $\vec{g}(u, v) = x(u, v)\vec{i} + y(u, v)\vec{j}$, where $x(u, v)$ and $y(u, v)$ are the component functions of the field \vec{g} , then we simply write:

$$\vec{g} : \begin{cases} x = x(u, v) \\ y = y(u, v) \end{cases}, (u, v) \in \Omega.$$

Here we must be careful because the same letter x is used for the variable x and, at the same time, like a name of a function $x(u, v)$ of variables u and v . The same is for the letter y . We intentionally did this because we wanted to show that the variable x was changed with a function $x(u, v)$ of variables u and v and the variable y was changed with a function $y(u, v)$ of the new variables u and v . This change of the "old" variables x and y with the "new" ones u and v is called a *change of variables*. More exactly, the deformation $\vec{g} : \Omega \rightarrow D$ is called a change of variables if it is a diffeomorphism (see Fig.13)

Let us partially divide the domain Ω into rectangles $\Omega_{ij} = [u_{i-1}, u_i] \times [v_{j-1}, v_j]$, $i = 1, 2, \dots, n$ and $j = 1, 2, \dots, m$. In each rectangle Ω_{ij} we choose a fixed marked point $P_{ij}(\xi_i, \eta_j)$. A small rectangle $[P_0P_1P_2P_3] = [u_{i-1}, u_i] \times [v_{j-1}, v_j]$ is deformed by \vec{g} into a curvilinear parallelogram $[M_0M_1M_2M_3]$ (see Fig.13 and Fig.14). First of all we want to estimate the area of this last curvilinear parallelogram $[M_0M_1M_2M_3]$ in language of the area of the rectangle $[P_0P_1P_2P_3]$ and of the deformation functions $x(u, v)$ and $y(u, v)$.

THEOREM 81. $area([M_0M_1M_2M_3]) \approx |J(\xi_i, \eta_j)| \cdot area([P_0P_1P_2P_3])$, where $J(\xi_i, \eta_j)$ is the value of the Jacobian

$$J(u, v) = \det \begin{pmatrix} \frac{\partial x}{\partial u}(u, v) & \frac{\partial x}{\partial v}(u, v) \\ \frac{\partial y}{\partial u}(u, v) & \frac{\partial y}{\partial v}(u, v) \end{pmatrix}$$

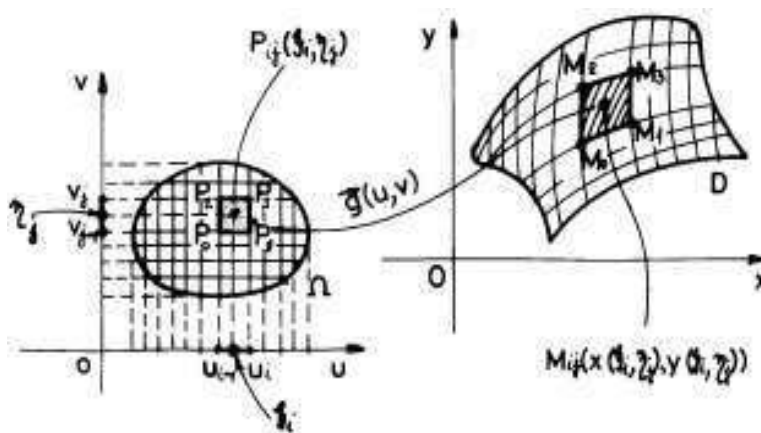

FIGURE 13

of $\vec{g}(u, v)$ computed at the point $P_{ij}(\xi_i, \eta_j)$. Here the sign " \approx " means "well approximation". This approximation is better and better if the norms of the divisions generated by $\{u_i\}$ and $\{v_j\}$ are smaller and smaller, i.e. if $u_i - u_{i-1} \rightarrow 0$ and $v_j - v_{j-1} \rightarrow 0$ for any i and j .

The above formula is usually written in a formal way:

$$(4.1) \quad dx dy = |J(u, v)| du dv.$$

We say that the initial element of area $du dv$ (which is the area of a small rectangle!), after the deformation process generated by \vec{g} , is "dilated" and becomes $|J(u, v)| du dv$. The dilation (or contraction) coefficient is exactly $|J(u, v)|$ in a small neighborhood of the point (u, v) . This means that the changes of areas are perfectly controlled by the Jacobian matrix of the deformation \vec{g} .

PROOF. We approximate the area of the curvilinear parallelogram $[M_0 M_1 M_2 M_3]$ with the area of the parallelogram $[M_0 M_1 M_2 M_3^*]$, generated by the vectors $\overrightarrow{M_0 M_1}$ and $\overrightarrow{M_0 M_2}$ (see Fig.14).

But the area of this last parallelogram is equal to $\left\| \overrightarrow{M_0 M_1} \times \overrightarrow{M_0 M_2} \right\|$.

Let compute $\overrightarrow{M_0 M_1} \times \overrightarrow{M_0 M_2}$. Firstly we have:

$$\begin{aligned} \overrightarrow{M_0 M_1} &= [x(u_i, v_{j-1}) - x(u_{i-1}, v_{j-1})] \vec{i} + [y(u_i, v_{j-1}) - y(u_{i-1}, v_{j-1})] \vec{j} = \\ &= \left[\frac{\partial x}{\partial u}(c_i, v_{j-1}) \vec{i} + \frac{\partial y}{\partial u}(c'_i, v_{j-1}) \vec{j} \right] (u_i - u_{i-1}). \end{aligned}$$

Here we used Lagrange formula for functions $t \rightsquigarrow x(t, v_{j-1})$ and $t \rightsquigarrow y(t, v_{j-1})$ on the interval $[u_{i-1}, u_i]$. Since the length of this last interval is small enough, since both functions just defined are of class C^1 , since

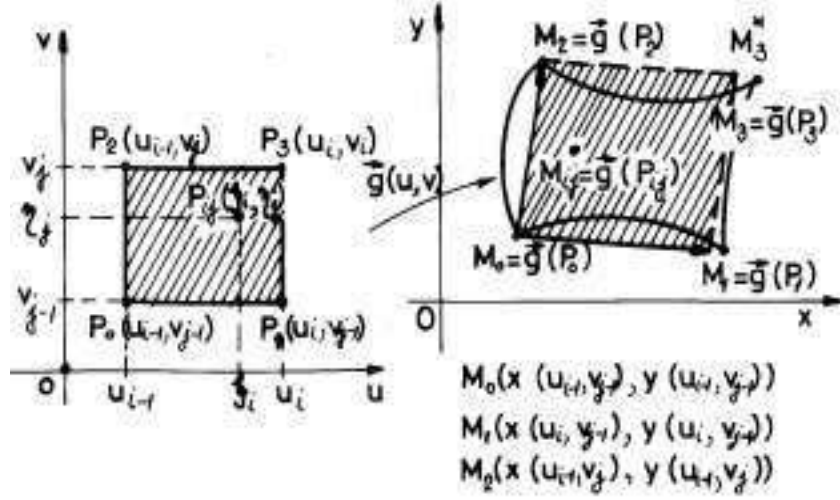

FIGURE 14

$c_i, c'_i, \xi_i \in [u_{i-1}, u_i]$ and since $\eta_j \in [v_{j-1}, v_j]$, we can further make the following approximation:

$$(4.2) \quad \overrightarrow{M_0 M_1} \approx \left[\frac{\partial x}{\partial u}(\xi_i, \eta_j) \vec{i} + \frac{\partial y}{\partial u}(\xi_i, \eta_j) \vec{j} \right] (u_i - u_{i-1}).$$

Secondly one gets:

$$\begin{aligned} \overrightarrow{M_0 M_2} &= [x(u_{i-1}, v_j) - x(u_{i-1}, v_{j-1})] \vec{i} + [y(u_{i-1}, v_j) - y(u_{i-1}, v_{j-1})] \vec{j} = \\ &= \left[\frac{\partial x}{\partial v}(u_{i-1}, d_j) \vec{i} + \frac{\partial y}{\partial v}(u_{i-1}, d'_j) \vec{j} \right] (v_j - v_{j-1}). \end{aligned}$$

Here we used Lagrange formula for functions $s \rightsquigarrow x(u_{i-1}, s)$ and $s \rightsquigarrow y(u_{i-1}, s)$ on the interval $[v_{j-1}, v_j]$. Since the length of this last interval is small enough, since both functions just defined are of class C^1 , since $d_j, d'_j, \eta_j \in [v_{j-1}, v_j]$ and since $\xi_i \in [u_{i-1}, u_i]$, we can further make the following approximation:

$$(4.3) \quad \overrightarrow{M_0 M_2} \approx \left[\frac{\partial x}{\partial v}(\xi_i, \eta_j) \vec{i} + \frac{\partial y}{\partial v}(\xi_i, \eta_j) \vec{j} \right] (v_j - v_{j-1}).$$

Hence

$$\begin{aligned} &\overrightarrow{M_0 M_1} \times \overrightarrow{M_0 M_2} \approx \\ &\approx \left[\frac{\partial x}{\partial u}(\xi_i, \eta_j) \cdot \frac{\partial y}{\partial v}(\xi_i, \eta_j) - \frac{\partial x}{\partial v}(\xi_i, \eta_j) \cdot \frac{\partial y}{\partial u}(\xi_i, \eta_j) \right] (u_i - u_{i-1})(v_j - v_{j-1}) \vec{k}. \end{aligned}$$

Thus

$$\left\| \overrightarrow{M_0 M_1} \times \overrightarrow{M_0 M_2} \right\| \approx$$

$$\begin{aligned} &\approx \left| \frac{\partial x}{\partial u}(\xi_i, \eta_j) \cdot \frac{\partial y}{\partial v}(\xi_i, \eta_j) - \frac{\partial x}{\partial v}(\xi_i, \eta_j) \cdot \frac{\partial y}{\partial u}(\xi_i, \eta_j) \right| \text{area}([P_0P_1P_2P_3]) = \\ &= |J(\xi_i, \eta_j)| \text{area}([P_0P_1P_2P_3]). \end{aligned}$$

Since $\text{area}([M_0M_1M_2M_3]) \approx \left\| \overrightarrow{M_0M_1} \times \overrightarrow{M_0M_2} \right\|$, we finally get:

$$\text{area}([M_0M_1M_2M_3]) \approx |J(\xi_i, \eta_j)| \text{area}([P_0P_1P_2P_3]),$$

i.e. the statement of the theorem. \square

THEOREM 82. (change of variables formula) *Let us preserve the above notation and hypotheses. Let $f : D \rightarrow \mathbb{R}$ be a piecewise continuous function defined on D . Then*

$$(4.4) \quad \iint_D f(x, y) dx dy = \iint_{\Omega} f(x(u, v), y(u, v)) |J(u, v)| du dv.$$

PROOF. Let us observe that the union of the nonoverlapping subdomains $D_{ij} = \overrightarrow{g}(\Omega_{ij})$, where $\Omega_{ij} = [u_{i-1}, u_i] \times [v_{j-1}, v_j]$, $i = 1, 2, \dots, n$ and $j = 1, 2, \dots, m$, well approximate (when the diameters $\text{diam}(\Omega_{ij})$ of Ω_{ij} go to zero) the entire domain D (see Fig.13). Thus, using theorem 81 and the definition of double integrals as the limit of double Riemann sums, we get:

$$\begin{aligned} \iint_D f(x, y) dx dy &\approx \sum_{i=1}^n \sum_{j=1}^m f(M_{ij}) \text{area}(D_{ij}) \approx \\ &\approx \sum_{i=1}^n \sum_{j=1}^m f(x(\xi_i, \eta_j), y(\xi_i, \eta_j)) \cdot |J(\xi_i, \eta_j)| \cdot (u_i - u_{i-1})(v_j - v_{j-1}) \approx \\ &\approx \iint_{\Omega} f(x(u, v), y(u, v)) |J(u, v)| du dv. \end{aligned}$$

Hence the two fixed numbers $\iint_D f(x, y) dx dy$ and

$$\iint_{\Omega} f(x(u, v), y(u, v)) |J(u, v)| du dv$$

become closer and closer! Therefore they must coincide, i.e.

$$\iint_D f(x, y) dx dy = \iint_{\Omega} f(x(u, v), y(u, v)) |J(u, v)| du dv,$$

what we wanted to prove. \square

Formula (4.4) is called "change of variables formula" and it is extremely useful in practice.

The most popular change of variables are the change of the Cartesian coordinates (x, y) with the polar coordinates (ρ, θ) :

$$(4.5) \quad \begin{cases} x = \rho \cos \theta \\ y = \rho \sin \theta \end{cases},$$

where ρ goes from 0 (without it!) up to ∞ and $\theta \in [0, 2\pi)$. The deformation induced by this change of variables is $\vec{g} : (0, \infty) \times [0, 2\pi) \rightarrow \mathbb{R}^2 \setminus \{(0, 0)\}$, $\vec{g}(\rho, \theta) = (\rho \cos \theta, \rho \sin \theta)$. It is important because it deforms the interior of a rectangle $\Omega = (0, R] \times [0, 2\pi)$, $R > 0$, into the interior of the disc $B((0, 0), R) = \{(x, y) : x^2 + y^2 \leq R^2\}$. Since some finite length smooth curves do not count for us during the double integration process, we will simply say that any disc in a fixed plane is the image after a deformation $\begin{cases} x = x_0 + \rho \cos \theta \\ y = y_0 + \rho \sin \theta \end{cases}$, $\rho \in (0, R)$, $\theta \in [0, 2\pi)$, of a rectangle from the (ρ, θ) -plane. Here (x_0, y_0) is the centre of the disc and R is its radius. The first one (see formula (4.5)) is a particular case of this last more general polar coordinates change. The Jacobian of the polar coordinates change is equal to

$$\det \begin{pmatrix} \cos \theta & -\rho \sin \theta \\ \sin \theta & \rho \cos \theta \end{pmatrix} = \rho \neq 0.$$

(see also [Po], Ch.11, Section 6). Hence formula (4.1) becomes:

$$(4.6) \quad dx dy = \rho d\rho d\theta.$$

For instance, let consider again the double integral of example 80 and let us change the Cartesian variables (x, y) with the polar coordinates (ρ, θ) (see formula (4.5)). Here $dx dy = \rho d\rho d\theta$. Thus, formula (4.4) can be applied:

$$\begin{aligned} \int \int_{D: x^2+y^2 \leq 9} x^2 y^2 dx dy &= \int_0^3 \left(\int_0^{2\pi} \rho^4 \cos^2 \theta \sin^2 \theta d\theta \right) \rho d\rho = \\ &= \int_0^3 \rho^5 \left(\int_0^{2\pi} \cos^2 \theta \sin^2 \theta d\theta \right) d\rho = \left(\frac{1}{4} \int_0^{2\pi} \sin^2 2\theta d\theta \right) \int_0^3 \rho^5 d\rho = \\ &= \left(\int_0^{2\pi} \frac{1 - \cos 4\theta}{2} d\theta \right) \cdot \frac{3^5}{4} = \frac{3^5 \pi}{4}. \end{aligned}$$

We can remark how easy become the calculations if we changed the variables!

4. CHANGE OF VARIABLES IN DOUBLE INTEGRALS. POLAR COORDINATES 257

EXAMPLE 81. Let us compute the inertia moment of the ellipse $\frac{x^2}{a^2} + \frac{y^2}{b^2} \leq 1$ w.r.t. Oy -axis. Since nothing is said on the density function, we take $f(x, y) = 1$. If one tries to compute the double integral

which appear here, $\int \int_{D: \frac{x^2}{a^2} + \frac{y^2}{b^2} \leq 1} x^2 dx dy$, by using only iterative formulas,

one will see that the calculations becomes very difficult. Let us try to use the following "general polar coordinates" change of variables:

$$\begin{cases} x = a\rho \cos \theta \\ y = b\rho \sin \theta \end{cases}, \rho \in (0, 1], \theta \in [0, 2\pi).$$

It is easy to see that in this last case $J = ab\rho$ and our integral becomes (we simply apply change of variables formula (4.4):

$$\begin{aligned} \int \int_{D: \frac{x^2}{a^2} + \frac{y^2}{b^2} \leq 1} x^2 dx dy &= \int_0^1 \left(\int_0^{2\pi} \rho^2 \cos^2 \theta d\theta \right) ab\rho d\rho = \\ &= ab \int_0^1 \rho^3 \left(\int_0^{2\pi} \cos^2 \theta d\theta \right) d\rho = ab \left(\int_0^1 \rho^3 d\rho \right) \left(\int_0^{2\pi} \cos^2 \theta d\theta \right) = \\ &= ab \frac{1}{4} \int_0^{2\pi} \frac{1 + \cos 2\theta}{2} d\theta = \frac{\pi ab}{4}. \end{aligned}$$

EXAMPLE 82. The area of the ellipse $\frac{x^2}{a^2} + \frac{y^2}{b^2} \leq 1$ can be immediately computed by using the above change of variables.

$$\text{area} = \int \int_{D: \frac{x^2}{a^2} + \frac{y^2}{b^2} \leq 1} dx dy = \int_0^1 \left(\int_0^{2\pi} d\theta \right) ab\rho d\rho = \pi ab.$$

In particular, the area of a disc of radius R is equal to πR^2 .

EXAMPLE 83. Sometimes the disc has not its centre in the origin of the axes. For instance, let us compute the mass centre of the disc $D : x^2 + y^2 + 4y \leq 0$ if the density function is $f(x, y) = \sqrt{x^2 + y^2}$. Since the equation of the disc can be written as $x^2 + (y + 2)^2 \leq 4$, we see that the centre of the disc is in $C(0, -2)$ and its radius is equal to 2. It is symmetric w.r.t. Oy -axis, geometrically and also from the point of view of statics (the mass is symmetrically expanded w.r.t. Oy -axis).

Hence $x_G = 0$. Let us compute

$$y_G = \frac{\iint_D y \sqrt{x^2 + y^2} dx dy}{\iint_D \sqrt{x^2 + y^2} dx dy}.$$

To compute these two double integrals we shall use the common polar coordinates (because the circle ∂D contains the origin! Otherwise this method fails!). Let us write the Cartesian equation of the disc in the language of polar coordinates: $\rho^2 \cos^2 \theta + \rho^2 \sin^2 \theta + 4\rho \sin \theta \leq 0$, or $\rho + 4 \sin \theta \leq 0$, or $0 < \rho \leq -4 \sin \theta$. This time, for any fixed value of θ , ρ goes between 0 and $-4 \sin \theta$ (Draw and look at it!). Now θ itself goes between π and 2π . Hence

$$\begin{aligned} \iint_D \sqrt{x^2 + y^2} dx dy &= \int_{\pi}^{2\pi} \left(\int_0^{-4 \sin \theta} \rho \cdot \rho d\rho \right) d\theta = \int_{\pi}^{2\pi} \frac{\rho^3}{3} \Big|_0^{-4 \sin \theta} d\theta = \\ &= -\frac{64}{3} \int_{\pi}^{2\pi} \sin^3 \theta d\theta = \frac{64}{3} \int_{\pi}^{2\pi} (1 - \cos^2 \theta) d(\cos \theta) = \\ &= \frac{64}{3} \left(\cos \theta - \frac{\cos^3 \theta}{3} \right) \Big|_{\pi}^{2\pi} = \frac{256}{9}. \end{aligned}$$

Now, we look at the last calculations and make some slight modifications in order to compute the double integral in the numerator:

$$\begin{aligned} \iint_D y \sqrt{x^2 + y^2} dx dy &= \int_{\pi}^{2\pi} \left(\int_0^{-4 \sin \theta} \rho^2 \sin \theta \cdot \rho d\rho \right) d\theta = \\ &= \int_{\pi}^{2\pi} \sin \theta \left(\frac{\rho^4}{4} \Big|_0^{-4 \sin \theta} \right) d\theta = \frac{256}{4} \int_{\pi}^{2\pi} \sin^5 \theta d\theta = \\ &= -64 \int_{\pi}^{2\pi} (1 - \cos^2 \theta)^2 d(\cos \theta) = \\ &= -64 \int_{\pi}^{2\pi} (1 - 2 \cos^2 \theta + \cos^4 \theta) d(\cos \theta) = \\ &= -64 \left[\cos \theta - \frac{2}{3} \cos^3 \theta + \frac{1}{5} \cos^5 \theta \right] \Big|_{\pi}^{2\pi} = -64 \cdot \frac{16}{15}. \end{aligned}$$

$$\text{Thus } y_G = \frac{-64 \cdot \frac{16}{15}}{\frac{256}{9}} = -\frac{12}{5}.$$

4. CHANGE OF VARIABLES IN DOUBLE INTEGRALS. POLAR COORDINATES 259

EXAMPLE 84. Sometimes the centre of the disc is not in the origin of the axes and the boundary of the disc does not pass through the origin. For instance, let us compute the mass of the disc $D : (x - 1)^2 + (y + 3)^2 \leq 1$ if the density function is $f(x, y) = x$. Let us use the following change of variables:

$$\begin{cases} x = 1 + \rho \cos \theta \\ y = -3 + \rho \sin \theta \end{cases}, \rho \in (0, 1), \theta \in [0, 2\pi).$$

Thus,

$$\text{mass}(D) = \iint_D x dx dy = \int_0^1 \left(\int_0^{2\pi} (1 + \rho \cos \theta) d\theta \right) \rho d\rho = \pi.$$

EXAMPLE 85. Let us compute for instance the mass of the plate $[A_0A_1A_2A_3]$ with the density function $f(x, y) = y$ (see Fig.15).

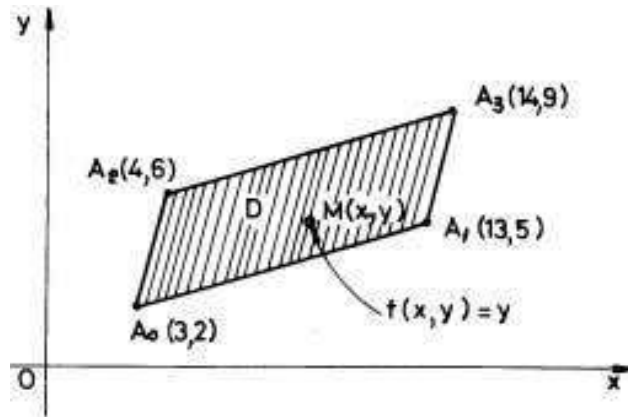

FIGURE 15

Since $\overrightarrow{A_0A_1} = 10\vec{i} + 3\vec{j}$ and $\overrightarrow{A_2A_3} = 10\vec{i} + 3\vec{j}$ as free vectors, we conclude that the domain $D = [A_0A_1A_2A_3]$ is a parallelogram. But, to compute the mass of D , i.e. the double integral $\iint_D y dx dy$ with the iterative formulas, it is not so easy. Let us try to change this "complicated" domain into a rectangle, on which it will be easy to integrate. We need some knowledge from a Linear Algebra course. Let us start with the square $\Omega = [0, 1] \times [0, 1]$ and let us try to find a "translated" linear mapping $\vec{g} : \mathbb{R}^2 \rightarrow \mathbb{R}^2$ which "without the translation part" is an isomorphism of vector spaces and such that $\vec{g}(\Omega) = D$. Thus

$\vec{g}(u, v) = (au + bv + e, cu + dv + h)$ (because of the linearity of the component functions of \vec{g} without the translation) and we only need to determine the six numbers a, b, c, d, e, h and then to prove that $\vec{g}(\Omega) = D$. We even force that the corners of the square $\Omega = [0, 1] \times [0, 1]$ to go exactly to the "corresponding" corners of the parallelogram (our feeling is that \vec{g} is a dilation of axes + a translation + a rotation + a linear deformation of angles!). Hence, the conditions: $\vec{g}(0, 0) = (3, 2)$, $\vec{g}(1, 0) = (13, 5)$, $\vec{g}(0, 1) = (4, 6)$ and $\vec{g}(1, 1) = (14, 9)$ (see Fig. 6.15) supply us with the values of a, b, c, d, e, h . In fact we do not need the last equality because such a function \vec{g} carries collinear vectors into collinear vectors (Why?). Namely, $a = 10, b = 1, c = 3, d = 4, e = 3$ and $h = 2$. Thus $\vec{g}(u, v) = (10u + v + 3, 3u + 4v + 2)$. Since the matrix $T = \begin{pmatrix} 10 & 1 \\ 3 & 4 \end{pmatrix}$ of the linear part $(u, v) \rightarrow (au + bv, cu + dv)$ of \vec{g} is invertible, we see that \vec{g} is a diffeomorphism from Ω to D , in particular \vec{g} is a smooth deformation (without "defects") of Ω into D . Moreover, it is also reversible, i.e. "one can come back in the same smoothly manner". The Jacobian of \vec{g} is exactly the determinant of the matrix T . Theorem 81 says that during the deformation process induced by \vec{g} the area of Ω increases $\det T = 36$ times. But why $\vec{g}(\Omega) = D$? Let us take a point $M \in [0, 1] \times [0, 1]$ and let us write its position vector w.r.t. a fixed Cartesian system $uO'v$: $\vec{O'M} = \alpha \vec{i}' + \beta \vec{j}'$ where $0 \leq \alpha, \beta \leq 1$. We need to prove that $\vec{g}(M) \in D$, i.e. that $(10\alpha + \beta + 3, 3\alpha + 4\beta + 2) \in D$, or, equivalently, that $V = (10\alpha + \beta, 3\alpha + 4\beta)$, as a free vector in the xOy -Cartesian system can be decomposed as a linear combination of vectors $\vec{A_0A_1} = 10\vec{i} + 3\vec{j}$ and $\vec{A_0A_2} = \vec{i} + 4\vec{j}$ with subunitary coefficients. Indeed, let us write:

$$(10\alpha + \beta)\vec{i} + (3\alpha + 4\beta)\vec{j} = \lambda(10\vec{i} + 3\vec{j}) + \eta(\vec{i} + 4\vec{j}),$$

or

$$\begin{cases} 10\alpha + \beta = 10\lambda + \eta \\ 3\alpha + 4\beta = 3\lambda + 4\eta \end{cases}.$$

Thus $\lambda = \alpha \in [0, 1]$ and $\eta = \beta \in [0, 1]$, i.e. $\vec{g}(M) \in D$. Now we are ready to compute the mass of the plate D . The Jacobian is equal to 36, thus

$$\begin{aligned} \text{mass}(D) &= \iint_D y dx dy = \int_{[0,1] \times [0,1]} \int (3u + 4v + 2) \cdot 36 du dv = \\ &= 36 \int_0^1 \left(\int_0^1 (3u + 4v + 2) dv \right) du = 36 \int_0^1 (3u + 4) du = \end{aligned}$$

$$= 36 \left(\frac{3}{2} + 4 \right) = 18 \cdot 11 = 18 \cdot (10 + 1) = 198.$$

Until this moment we considered only double integrals on bounded domains. A similar theory can be done for double integrals on unbounded domains (see also the improper integrals of the first type).

For instance, let us compute again (we computed it with the help of an integral with a parameter) and almost immediately the famous Poisson's integral $I = \int_0^\infty e^{-x^2} dx$.

$$I^2 = \int_0^\infty e^{-x^2} dx \cdot \int_0^\infty e^{-y^2} dy = \int_{D: x \geq 0, y \geq 0} \int e^{-x^2-y^2} dx dy =$$

$$\int_{y=0}^{\rho \sin \theta} \int_{x=0}^{\rho \cos \theta} \rho e^{-\rho^2} \left(\int_0^{\frac{\pi}{2}} d\theta \right) d\rho = \frac{\pi}{2} \left(-\frac{1}{2} e^{-\rho^2} \right) \Big|_0^\infty = \frac{\pi}{4}.$$

Thus $I = \frac{\sqrt{\pi}}{2}$. The integral $\int_{D: x \geq 0, y \geq 0} \int e^{-x^2-y^2} dx dy$ is an improper dou-

ble integral of the first type (the function is bounded but the domain is unbounded). Formula (4.5) and the theory of improper simple integrals are sufficient for the practical problems related to improper double integrals.

For instance, let us consider the following improper double integral

of the second type $J = \int_{D: x^2+y^2 \leq 1} \int \frac{1}{\sqrt[3]{x^2+y^2}} dx dy$. In this case the domain

is bounded but the function $f(x, y) = \frac{1}{\sqrt[3]{x^2+y^2}}$ is not bounded at $(0, 0)$.

Like in the situation of an improper simple integral of the second type, we isolate the singularity by a neighborhood (a small disc in the 2- D case) $D_\varepsilon : x^2 + y^2 \leq \varepsilon^2$, for a small $\varepsilon > 0$ and write:

$$J = \lim_{\varepsilon \rightarrow 0} \int_{D \setminus D_\varepsilon: \varepsilon^2 \leq x^2+y^2 \leq 1} \int \frac{1}{\sqrt[3]{x^2+y^2}} dx dy =$$

$$\int_{y=0}^{\rho \sin \theta} \int_{x=0}^{\rho \cos \theta} \rho^{-\frac{2}{3}} \rho d\theta d\rho = 2\pi \lim_{\varepsilon \rightarrow 0} \left[\frac{\rho^{\frac{4}{3}}}{\frac{4}{3}} \right] \Big|_\varepsilon^1 = \frac{3}{2}\pi.$$

Here we used the formula $dx dy = \rho d\rho d\theta$. Pay attention, do not forget ρ , the Jacobian of the deformation \vec{g} , i.e. the dilation coefficient of areas when one passes from rectangles to discs!

REMARK 30. Sometimes we encounter the following type of problems. We know that the area of a domain D is computed as follows:

$$(4.7) \quad \sigma(D) = \int_{-\frac{\sqrt{15}}{4}}^{\frac{\sqrt{15}}{4}} \left(\int_{1-\sqrt{1-y^2}}^{3-\sqrt{4-y^2}} dx \right) dy.$$

a) The first problem is to describe the domain D . b) The second problem is to change the order of integration in formula (4.7). Looking at the iterated integrals of (4.7) we see that while y goes between $-\frac{\sqrt{15}}{4}$ and $\frac{\sqrt{15}}{4}$, for any fixed value of y in this interval, $x \in [1 - \sqrt{1-y^2}, 3 - \sqrt{4-y^2}]$, i.e.

$$1 - \sqrt{1-y^2} \leq x \leq 3 - \sqrt{4-y^2}.$$

This double inequality can be decomposed into two inequalities: $(x-1)^2 + y^2 \leq 1$, i.e. the disc with centre at $C_1(1,0)$ and radius $r = 1$ and $(x-3)^2 + y^2 \geq 4$, i.e. the exterior of the open disc with centre at $C_2(3,0)$ and radius $R = 2$. To change the order of integration it is not so easy. First of all we see that the domain D described by the last two inequalities:

$$D : \begin{cases} (x-1)^2 + y^2 \leq 1 \\ (x-3)^2 + y^2 \geq 4 \end{cases}$$

is simple w.r.t. the Oy -axis but it is not simple w.r.t. the Ox -axis. However, it is symmetric w.r.t. Ox -axis. Hence the area of D is two times the area of the superior part of D . i.e. the domain D^* :

$$D^* : \begin{cases} (x-1)^2 + y^2 \leq 1 \\ (x-3)^2 + y^2 \geq 4 \end{cases}, y \geq 0.$$

Even if this last domain is not simple with respect to the Ox -axis (make a drawing and see this!). In fact D^* can be decomposed into a union of two nonoverlapping domains D_1^* and D_2^* corresponding to $x \in [0, 1]$ and to $x \in [1, \frac{5}{4}]$ respectively (prove this!). By making explicit the expression of y as a function of x in the equalities $(x-1)^2 + y^2 = 1$ and $(x-3)^2 + y^2 = 4$ we finally get:

$$\sigma(D) = 2\sigma(D^*) = 2 \left[\int_0^1 \left(\int_0^{\sqrt{2x-x^2}} dy \right) dx + \int_1^{\frac{5}{4}} \left(\int_{\sqrt{6x-x^2-5}}^{\sqrt{2x-x^2}} dy \right) dx \right].$$

Hence we succeeded to change the order of integration in formula (4.7). A nice challenge for the reader is to obtain the same thing but, without using the explicit drawing of D , i.e. to use only the algebraic description of D !

5. Problems and exercises

1. Compute the following double integrals:

a) $\int_{x \in [0,1]} \int_{y \in [0,1]} e^{x+y} dx dy$; b) $\int_{x \in [0,\infty)} \int_{y \in [1,2]} e^{-xy} dx dy$;

c) $\iint_D xy^2 dx dy$, where D is the domain bounded by $y = 2x$ and

$y = x^2$; d) $\iint_D x^2 y^2 dx dy$, where D is the finite domain bounded by $x = 0$, $y = 0$ and $2x - 3y + 1 = 0$.

2. Compute the mass of the lamina D bounded by $y = x^2$ and $y = 2\sqrt{x}$, where $x \in [0, 1]$, if the density function is $f(x, y) = \sqrt{xy}$.

3. Compute the static moments of the plate $D : \begin{cases} x^2 + y^2 \leq 4 \\ 3y \geq x^2 \end{cases}$ relative to both axes and then find the coordinates of its mass centre.

4. Find the mass and the mass centre of the disc $D : x^2 + y^2 \leq 25$ with the density function $f(x, y) = 1 + |y|$.

5. Find the mass and the inertia moment w.r.t. O of the homogeneous ellipse $\frac{x^2}{a^2} + \frac{y^2}{4a^2} \leq 1$ if $f(x, y) = 3kg/m^2$.

6. Find the inertia moment of the plate $D : x^2 + y^2 - 3x \leq 0$ w.r.t. Ox -axis if the density function is $f(x, y) = \frac{1}{\sqrt{x^2+y^2+1}}$.

7. Compute $\iint_D \frac{\ln(x^2+y^2)}{x^2+y^2} dx dy$, for $D : 1 \leq x^2 + y^2 \leq e^2$. But for $D' : 0 \leq x^2 + y^2 \leq e^2$?

8. Find the static moment of $D : x^2 + y^2 \leq 2, x \leq y$ w.r.t. Oy -axis.

9. Compute the mass of the disc $x^2 + y^2 - x - y \leq 0$ if the density function is $f(x, y) = x + y$.

10. Let $A(1, -\sqrt{3})$, $B(1, \sqrt{3})$ and $C(-2, 0)$ be three points in the xOy -plane. Compute the work of the field $\vec{F}(x, y) = x^3 \vec{i} - y^3 \vec{j}$ along the direct oriented (trigonometric way!) curve $[ABCA]$, by using Green formula.

11. Compute directly and then by using Green formula the static moment of order 3 w.r.t. O of the square-plate bounded by the square $ABCD$, where $A(0, -1)$, $B(1, 0)$, $C(0, 1)$ and $D(-1, 0)$. (like usually take $f = 1$!).

12. Use Green formula (or any other formula) to compute

$\oint_{arc[ABCOA]^+} ydx - xdy$ if $A(4, -2)$, $B(4, 0)$, $C(4, 2)$, $[COA]$ is an arc of the parabola $x = y^2$, $[AB]$ is a segment of a straight line and $arc[BC]$ is an arc of the circle $(x - 4)^2 + (y - 1)^2 = 1$, $x \geq 4$ which connect B and C .

13. Let $\{A(i, 2i + 1)\}$, $i = 1, 2, \dots, n$ and $A_{n+1}(n + 1, 0)$. Use example 78 like a model to compute $\iint_D xdx dy$, $\iint_D ydx dy$ and $\iint_D xydx dy$, where D is the domain bounded by the closed polygonal line $[OA_1A_2 \dots A_nA_{n+1}O]$.

14. Find the areas bounded by the following curves:

a) $\begin{cases} y = \sin x \\ y = 0 \end{cases}$, $x \in [0, 2\pi]$; b) $y^2 = ax$, $x^2 = by$, $a > 0$, $b > 0$; c) $|x| + |y| = 1$; d) $\begin{cases} x^2 + y^2 = R^2 \\ \frac{x^2}{a^2} + \frac{y^2}{b^2} \leq 1 \end{cases}$ (discussion on a, b, R).

15. Use an appropriate change of variables to compute $\iint_D xydx dy$,

where:

a) D is the parallelogram generated by the vectors \overrightarrow{OA} and \overrightarrow{OB} , with $A(1, 2)$ and $B(2, 1)$.

b) D is the domain bounded by the lines: $y = x$, $y = 2x$, $x + y = 1$ and $x + y = 4$.

c) D is the domain bounded by the curves: $x = y^2$, $x = 4y^2$, $x = 1$, $y > 0$ and $x = 4$.

CHAPTER 7

Triple integrals

1. What is a triple integral on a parallelepiped?

Double integrals $\iint_D f(x, y) dx dy$ are connected with plane domains

D , i.e. with 2-dimensional objects. When we compute such an integral we always finally come to the computation of two simple integrals.

If one substitutes plane domains with domains D in the 3-dimensional space \mathbb{R}^3 , one gets a more sophisticated notion, namely the notion of a

triple integral $\iiint_D f(x, y, z) dx dy dz$. Here $dx dy dz$ is called an element

of volume and $f(x, y, z)$ stands for "the density" function, etc. Since all the theory of such triple integrals is nothing else than a slight generalization of the theory of double integrals, we do not insist more on it. Thus some proofs will be omitted in this chapter, because the reader can easily recover them by a simple imitation of the corresponding proofs made by us in the case of the double or simple integrals.

DEFINITION 25. *By a space domain D we mean a subset D of \mathbb{R}^3 which is closed, bounded, connected and its boundary ∂D is a piecewise smooth surface of class C^1 (see below the definition of this notion or look in any book of Differential Geometry). A couple $\Omega = (D, f)$ of a space domain D and a piecewise continuous function $f : D \rightarrow \mathbb{R}$ is said to be a solid in \mathbb{R}^3 . Here a piecewise continuous function f defined on D is a function defined on D , which is continuous except a subset A of D such that $\text{vol}(A) = 0$ (we below recall the notion of a volume or a measure in \mathbb{R}^3 . See also the general definition 7). We say that a piecewise smooth surface of class C^1 is simply the image $\vec{g}(W)$ of a field $\vec{g} : W \rightarrow \mathbb{R}^3$, where W is a plane domain, such that \vec{g} is of class C^1 except a subset B of W of zero area (i.e. $\text{area}(B) = 0$). If $f = 1$ we also call D a solid. Sometimes, even we do not specify anything about f , we call such a space domain D a solid. The function f is called a density function because it associates to any point $M(x, y, z)$ of D , a number $f(x, y, z)$, "the density of the solid at M ".*

For other definitions on topological notions in \mathbb{R}^3 we send the reader to any course of Differential Calculus (Multivariable Analysis), for instance to [Po].

A parallelepiped domain D is a space domain of the form $D = [a, b] \times [c, d] \times [e, g]$. In Fig.1 we see such a domain $\Omega = [ABCEA'B'C'E']$ and its projections on the coordinates planes xOy , yOz and zOx .

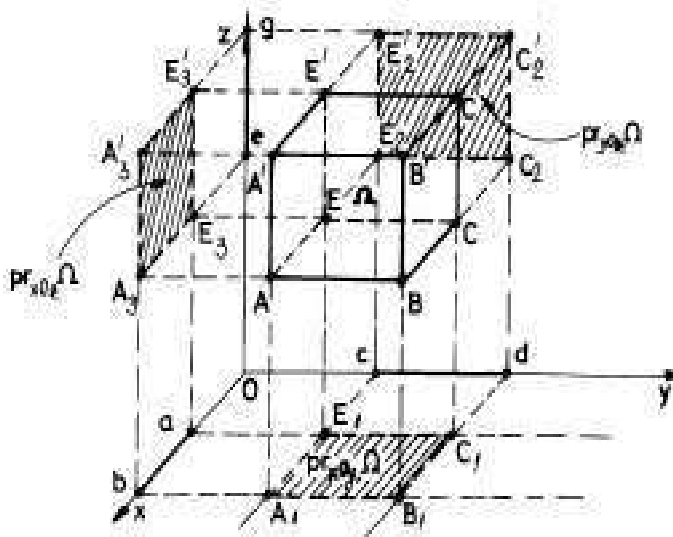

FIGURE 1

Let now $D = [a, b] \times [c, d] \times [e, g]$ be a parallelepiped space domain and let us consider the following divisions $\Delta_x : a = x_0 < x_1 < \dots < x_n = b$, $\Delta_y : c = y_0 < y_1 < \dots < y_m = d$, $\Delta_z : e = z_0 < z_1 < \dots < z_p = g$ of the segments $[a, b]$, $[c, d]$ and $[e, g]$ respectively. Let $\Delta = \Delta_x \times \Delta_y \times \Delta_z = \{D_{ijk} = [x_{i-1}, x_i] \times [y_{j-1}, y_j] \times [z_{k-1}, z_k]\}$ be the 3-dimensional division of D generated by Δ_x , Δ_y and Δ_z (see Fig.2).

Let

$$\{P_{ijk}(\xi_i, \eta_j, \theta_k)\}, \xi_i \in [x_{i-1}, x_i], \eta_j \in [y_{j-1}, y_j], \theta_k \in [z_{k-1}, z_k]$$

(i.e. $P_{ijk} \in D_{ijk}$) be a fixed set of marking points of the division Δ and let

$$\|\Delta\| = \max_{i,j,k} \{diam(D_{ijk})\}$$

be the norm of the division Δ . Let $f : D \rightarrow \mathbb{R}$ be a density function defined on D . If $\|\Delta\|$ is small enough, we can well approximate the mass of the solid $(D_{ijk}, f|_{D_{ijk}})$ by the number $f(\xi_i, \eta_j, \theta_k) \cdot vol(D_{ijk})$, i.e. with the density at the fixed point P_{ijk} multiplied by the volume

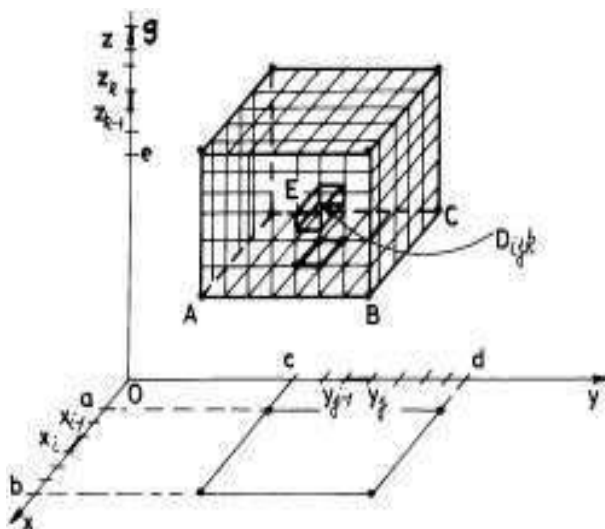

FIGURE 2

of D_{ijk} . Thus, the entire mass of D can be well approximated by the following triple Riemann sum:

$$(1.1) \quad S_f(\Delta; \{P_{ijk}(\xi_i, \eta_j, \theta_k)\}) = \sum_{i=1}^n \sum_{j=1}^m \sum_{k=1}^p f(\xi_i, \eta_j, \theta_k) \cdot \text{vol}(D_{ijk}),$$

which corresponds to the density function f , to the division Δ and to the set of marking points $\{P_{ijk}\}$, $i = 1, 2, \dots, n$, $j = 1, 2, \dots, m$, $k = 1, 2, \dots, p$.

DEFINITION 26. We say that a function $f : D = [a, b] \times [c, d] \times [e, g] \rightarrow \mathbb{R}$ is (Riemann) integrable on D if there exists a real number I such that for any $\varepsilon > 0$, there exists a real number δ_ε (depending on ε) with the property that

$$|I - S_f(\Delta; \{P_{ijk}(\xi_i, \eta_j, \theta_k)\})| < \varepsilon$$

for any division Δ with $\|\Delta\| < \delta_\varepsilon$ and for any set of marking points

$\{P_{ijk}(\xi_i, \eta_j, \theta_k)\}$ of Δ . This number I is denoted by $\iiint_D f(x, y, z) dx dy dz$

and it is called the triple integral of f on the domain D . Here $dx dy dz$ is called an element of volume and it symbolizes a small volume $\text{vol}(D_{ijk})$. In general, $dx dy dz$ is not equal to the product $dx \cdot dy \cdot dz$. But here it is so, because the volume of a small parallelepiped D_{ijk} is "virtually"

equal to $dx \cdot dy \cdot dz$. We see that $I = \iiint_D f(x, y, z) dx dy dz$ is the mass of the solid (D, f) and $\text{vol}(D) = \iiint_D dx dy dz$ because for $f = 1$ each Riemann sum $S_f(\Delta; \{P_{ijk}(\xi_i, \eta_j, \theta_k)\})$ is equal to $\text{vol}(D)$.

It is easy to see that the above defined number I is unique.

Introducing Darboux sums like in the case of the double or simple integrals, it is not difficult to prove a Darboux type criterion and the following basic result.

THEOREM 83. (*iterative formulas for parallelepipeds*) Let $D = [a, b] \times [c, d] \times [e, g]$ be a parallelepiped space domain and let $f : D \rightarrow \mathbb{R}$ be a piecewise continuous (see the definition above) function defined on D . Then f is Riemann integrable on D and

$$(1.2) \quad \iiint_D f(x, y, z) dx dy dz = \int_a^b \left(\int_c^d \left(\int_e^g f(x, y, z) dz \right) dy \right) dx.$$

Moreover, the order of integration in this formula can be changed. This formula says that first of all we compute the simple integral with two parameters x and y , $J(x, y) = \int_e^g f(x, y, z) dz$, then we compute the simple integral $K(x) = \int_c^d J(x, y) dy$ with one parameter x , and finally we compute $\int_a^b K(x) dx$ and find the value of $\iiint_D f(x, y, z) dx dy dz$. This means that the computation of a triple integral on a parallelepiped domain reduces to the calculation of three simple integrals, step by step, i.e. in an iterative style.

PROOF. For simplifying the reasoning, we assume that f is continuous on D . Let us denote

$$T = \int_a^b \left(\int_c^d \left(\int_e^g f(x, y, z) dz \right) dy \right) dx$$

and

$$I = \iiint_D f(x, y, z) dx dy dz.$$

Since, by definition, I exists if it is the unique limit point of the Riemann sums $S_f(\Delta; \{P_{ijk}(\xi_i, \eta_j, \theta_k)\})$, we shall prove that T itself is the unique limit point of such type of sums. So I exists and it will be equal to T . Let us preserve the notation from the statement of the theorem.

Since $J(x, y) = \int_e^g f(x, y, z)dz$ can be well approximated by Riemann sums of the form:

$$J(x, y) \approx \sum_{k=1}^p f(x, y, \theta_k)(z_k - z_{k-1}),$$

we see that $K(x) = \int_c^d J(x, y)dy$ can be well approximated by sums of the following type:

$$(1.3) \quad K(x) \approx \sum_{k=1}^p \left(\int_c^d f(x, y, \theta_k)dy \right) (z_k - z_{k-1}).$$

Each integral $\int_c^d f(x, y, \theta_k)dy$ can be well approximated by Riemann sums of the type:

$$\int_c^d f(x, y, \theta_k)dy \approx \sum_{j=1}^{m_k} f(x, \eta_j^{(k)}, \theta_k)(y_j^{(k)} - y_{j-1}^{(k)}).$$

We put together all the divisions $\Delta_y^{(k)} : c = y_0^{(k)} < \dots < y_{m_k}^{(k)} = d, k = 1, 2, \dots, p$ and form a bigger division $\Delta_y : c = y_0 < y_1 < \dots < y_m = d$. Hence

$$K(x) \approx \sum_{k=1}^p \sum_{j=1}^m f(x, \eta_j, \theta_k)(y_j - y_{j-1})(z_k - z_{k-1}).$$

Now, $T = \int_a^b K(x)dx$ can be well approximated by sums of the type:

$$T \approx \sum_{k=1}^p \sum_{j=1}^m \left(\int_a^b f(x, \eta_j, \theta_k)dx \right) (y_j - y_{j-1})(z_k - z_{k-1}).$$

But

$$\int_a^b f(x, \eta_j, \theta_k)dx \approx \sum_{i=1}^{n_{jk}} f(\xi_i^{(jk)}, \eta_j, \theta_k)(x_i^{(jk)} - x_{i-1}^{(jk)}).$$

By putting together all the divisions $\Delta_x^{(jk)} : a = x_0^{(jk)} < \dots < x_{n_{jk}}^{(jk)} = b, j = 1, 2, \dots, m, k = 1, 2, \dots, p$ we get that

$$\begin{aligned} T &\approx \sum_{k=1}^p \sum_{j=1}^m \sum_{i=1}^n f(\xi_i, \eta_j, \theta_k)(x_i - x_{i-1})(y_j - y_{j-1})(z_k - z_{k-1}) = \\ &= \sum_{i=1}^n \sum_{j=1}^m \sum_{k=1}^p f(\xi_i, \eta_j, \theta_k) \cdot \text{vol}(D_{ijk}), \end{aligned}$$

because of the commutative and associative properties of the usual addition of real numbers. Hence T can be well approximated by Riemann sums of the type (1.1), i.e. $I = T$. □

EXAMPLE 86. Let us compute the mass of the unitary cube $D = [0, 1] \times [0, 1] \times [0, 1]$ with the density function $f(x, y, z) = 3xyz + 1$. The iterative method described above will be used.

$$\begin{aligned}
 \text{mass}(D) &= \iiint_D (3xyz + 1) dx dy dz = \\
 &= \int_0^1 \left(\int_0^1 \left(\int_0^1 (3xyz + 1) dz \right) dy \right) dx = \\
 &= \int_0^1 \left(\int_0^1 \left[\frac{3xyz^2}{2} + z \right] \Big|_{z=0}^{z=1} dy \right) dx = \\
 &= \int_0^1 \left(\int_0^1 \left[\frac{3xy}{2} + 1 \right] dy \right) dx = \int_0^1 \left[\frac{3xy^2}{4} + y \right] \Big|_{y=0}^{y=1} dx = \\
 &= \int_0^1 \left[\frac{3x}{4} + 1 \right] dx = \left[\frac{3x^2}{8} + x \right] \Big|_{x=0}^{x=1} = \frac{11}{8}.
 \end{aligned}$$

Formulas for mass centres, static moments relative to coordinate planes and inertia moments of solids can be immediately written by a simple analogy with the similar formulas for laminas. Let (D, f) be a solid, where D is a parallelepiped space domain. Then the coordinates of the mass centre G of D are:

$$(1.4) \quad x_G = \frac{\iiint_D x f(x, y, z) dx dy dz}{\iiint_D f(x, y, z) dx dy dz}, \quad y_G = \frac{\iiint_D y f(x, y, z) dx dy dz}{\iiint_D f(x, y, z) dx dy dz},$$

$$z_G = \frac{\iiint_D z f(x, y, z) dx dy dz}{\iiint_D f(x, y, z) dx dy dz}.$$

If the solid (D, f) is rotating around Oz -axis say, then the inertia moment $I_z = \iiint_D (x^2 + y^2) f(x, y, z) dx dy dz$, etc. All of these formulas can be deduced exactly like in the case of double integrals.

2. Triple integrals on a general domain.

A *general domain* is a closed, connected and bounded domain D in \mathbb{R}^3 with its boundary ∂D a piecewise smooth surface (see definition 25). We recall the notion of a volume or measure associated to a domain D . By an *elementary domain in \mathbb{R}^3* we mean a finite union of parallelepiped domains $D_i = [a_i, b_i] \times [c_i, d_i] \times [e_i, g_i]$, $i = 1, 2, \dots, n$ such that if $i \neq j$, the intersection $D_i \cap D_j$ is a subset of \mathbb{R}^3 without interior points, i.e. it is not possible to find an open ball $B(M_0, r) = \{M(x, y, z) : \|\overrightarrow{M_0M}\| < r\}$ which is included in $D_i \cap D_j$. Look in Fig.3 such an elementary domain Ω .

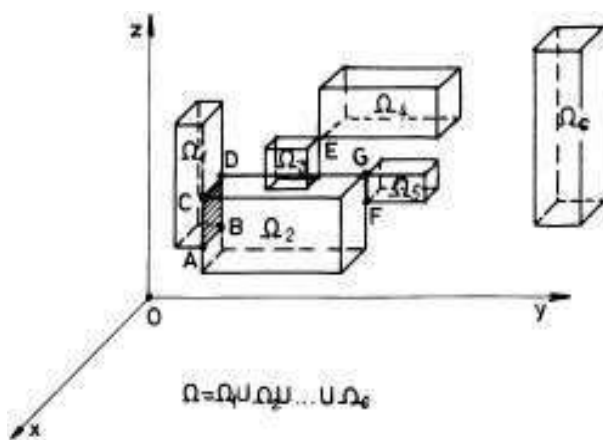

FIGURE 3

The volume of such an elementary domain is equal, by definition, to the sum of all volumes of the component parallelepipeds. Let us recall definition 7 of a volume (measure in the 3-dimensional case).

DEFINITION 27. A subset D of \mathbb{R}^3 has a volume $vol(D) \in \mathbb{R}_+$ if for any small real number $\varepsilon > 0$ there exist two elementary domains E_{int} and E_{ext} such that:

- 1) $E_{int} \subset D \subset E_{ext}$,
- 2) $vol(E_{ext}) - vol(E_{int}) < \varepsilon$.
- 3) $vol(E_{int}) \leq vol(D) \leq vol(E_{ext})$.

This means that a subset $D \subset \mathbb{R}^3$ has a volume $vol(D)$, a nonnegative real number, if and only if there exist two towers of elementary domains $\{E_{int}^{(j)}\}$ and $\{E_{ext}^{(j)}\}$ such that

$$(2.1) \quad E_{int}^{(1)} \subset E_{int}^{(2)} \subset \dots \subset E_{int}^{(k)} \subset \dots \subset D \subset \dots \subset E_{ext}^{(m)} \subset \dots \subset E_{ext}^{(2)} \subset E_{ext}^{(1)},$$

$vol(E_{ext}^{(m)}) \searrow vol(D)$ and $vol(E_{int}^{(k)}) \nearrow vol(D)$ as m and k are convergent to ∞ (become larger and larger). Since $vol(E_{ext}^{(m)}) - vol(E_{int}^{(m)}) \rightarrow 0$ as $m \rightarrow \infty$, $vol(D)$ is the unique real number which is contained in all intervals $[vol(E_{int}^{(m)}), vol(E_{ext}^{(m)})]$, $m = 1, 2, \dots$ (see Cantor's axiom in [Po]).

Using this definition, it is not difficult to prove that a finite set of points, of segments of finite length smooth curves, or of smooth surfaces, have volume zero. In particular, the boundary ∂D of a general domain D has volume zero. As a consequence, a general domain D has a finite volume, $vol(D)$. It is also easy to see that a bounded subset A of \mathbb{R}^3 , which has no interior points, has a volume $vol(A)$ and this last one is equal to zero.

The volume function $D \rightsquigarrow vol(D)$ is an additive function, i.e. $vol(D_1 \cup D_2) = vol(D_1) + vol(D_2) - vol(D_1 \cap D_2)$ and it is an increasing function, i.e. $D \subset D'$ implies $vol(D) \leq vol(D')$.

Let now (D, f) be a solid, i.e. D is a general domain and $f : D \rightarrow \mathbb{R}$ is a piecewise continuous function. A *division (partition)* Δ of D is a finite set of general subdomains $\{D_i\}$, $i = 1, 2, \dots, n$ of D such that $\cup_{i=1}^n D_i = D$ and for $i \neq j$, $D_i \cap D_j$ is a subset with no interior points (the empty set, a finite number of points, smooth curves, smooth surfaces, etc.). The *norm* of Δ is the nonnegative real number $\|\Delta\| = \max \{diam(D_i) : i = 1, 2, \dots, n\}$, where $diam(D_i) = \sup \left\{ \|\overrightarrow{MM'}\| : M, M' \in D_i \right\}$. We usually denote $\Delta = \{D_i\}$. A set of marking points $\{P_i(\xi_i, \eta_i, \theta_i)\}$, $P_i \in D_i$, $i = 1, 2, \dots, n$, is usually associated to a division Δ . Let

$$S_f(\Delta, \{P_i(\xi_i, \eta_i, \theta_i)\}) = \sum_{i=1}^n f(\xi_i, \eta_i, \theta_i) vol(D_i)$$

be the Riemann sum which corresponds to the division Δ and to the set of marking points $\{P_i(\xi_i, \eta_i, \theta_i)\}$, $i = 1, 2, \dots, n$.

DEFINITION 28. We say that a function $f : D \rightarrow \mathbb{R}$ is (Riemann) integrable if there exists a real number I denoted by $\iiint_D f(x, y, z) dx dy dz$, such that if $\varepsilon > 0$, there is a $\delta > 0$ which depends on ε , with

$$|I - S_f(\Delta, \{P_i(\xi_i, \eta_i, \theta_i)\})| < \varepsilon$$

for any division Δ with $\|\Delta\| < \delta$ and for any set $\{P_i(\xi_i, \eta_i, \theta_i)\}$ of marking points of the division Δ . This means that we can well approximate the number I with Riemann sums of the form $S_f(\Delta, \{P_i(\xi_i, \eta_i, \theta_i)\})$,

when $\|\Delta\| \rightarrow 0$. $I = \iiint_D f(x, y, z) dx dy dz$ is said to be the triple integral of f on the domain D and $dx dy dz$ is called an element of volume of D .

This number I is unique

All the properties of double integrals can be extended to triple integrals.

THEOREM 84. *Let D be a space domain and let $f : D \rightarrow \mathbb{R}$ be a Riemann integrable function. Then f must be bounded.*

PROOF. Let us fix a value for ε , say $\varepsilon = 1$, in the above definition 28. This last definition says that there exists at least one division $\Delta = \{D_i\}$, $i = 1, 2, \dots, n$ such that $|I - S_f(\Delta, \{P_i(\xi_i, \eta_i, \theta_i)\})| < 1$ for any set of marking points $\{P_i\}$ of the division Δ . A consequence of this last inequality is that the Riemann sums $S_f(\Delta, \{P_i(\xi_i, \eta_i, \theta_i)\})$ remains bounded when we arbitrarily change the set of marking points $\{P_i\}$, $P_i \in D_i$, $i = 1, 2, \dots, n$. If f were unbounded, it were unbounded at least in a subdomain D_{i_0} . This means that there exists a sequence of points $\{P_{i_0}^{(m)}\}$, $P_{i_0}^{(m)} \in D_{i_0}$, $m = 1, 2, \dots$ with $|f(P_{i_0}^{(m)})| \rightarrow \infty$ when $m \rightarrow \infty$. We see now that in the corresponding Riemann sums,

$$S_f(\Delta, \{P_i^{(m)}(\xi_i^{(m)}, \eta_i^{(m)}, \theta_i^{(m)})\}) = \sum_{i=1}^n f(\xi_i^{(m)}, \eta_i^{(m)}, \theta_i^{(m)}) \text{vol}(D_i),$$

where all the points $P_i^{(m)} = P_i$ are fixed, except $P_{i_0}^{(m)}$ which is moving, the i_0 -terms, $f(\xi_{i_0}^{(m)}, \eta_{i_0}^{(m)}, \theta_{i_0}^{(m)}) \text{vol}(D_{i_0})$ is unbounded to ∞ or to $-\infty$. Hence, the set of all Riemann sums $S_f(\Delta, \{P_i^{(m)}(\xi_i^{(m)}, \eta_i^{(m)}, \theta_i^{(m)})\})$ cannot remain bounded. A contradiction with the above observation! Thus, f must be bounded. \square

This last result says that the class of integrable functions is included in the class of bounded functions. This is why any function considered by us in the following is assumed to be bounded.

Let D be a domain with a volume $\text{vol}(D)$, let $\Delta = \{D_i\}$, $i = 1, 2, \dots, n$ be a division of D and let f be a bounded function defined on D with values in \mathbb{R} . Let $m_i = \inf\{f(x, y, z) : (x, y, z) \in D_i\}$ and let $M_i = \sup\{f(x, y, z) : (x, y, z) \in D_i\}$ for any $i = 1, 2, \dots, n$. Then

$$s_\Delta(f) = \sum_{i=1}^n m_i \cdot \text{vol}(D_i)$$

is called the *inferior Darboux sum* of f relative to Δ and

$$S_{\Delta}(f) = \sum_{i=1}^n M_i \cdot \text{vol}(D_i)$$

is said to be the *superior Darboux sum* of f relative to Δ . It is clear that

$$m \cdot \text{vol}(D) \leq s_{\Delta}(f) \leq S_f(\Delta, \{P_i(\xi_i, \eta_i, \theta_i)\}) \leq S_{\Delta}(f) \leq M \cdot \text{vol}(D),$$

for any set of marking points $\{P_i(\xi_i, \eta_i, \theta_i)\}$ of the division Δ , where $m = \inf\{f(x, y, z) : (x, y, z) \in D\}$ and $M = \sup\{f(x, y, z) : (x, y, z) \in D\}$. Since the set $\{s_{\Delta}(f) : \Delta \text{ goes on the set of all divisions of } D\}$ is upper bounded by $M \cdot \text{vol}(D)$, it has a least upper bound $I_*(f)$. Since the set $\{S_{\Delta}(f) : \Delta \text{ goes on the set of all divisions of } D\}$ is lower bounded by $m \cdot \text{vol}(D)$, it has a greatest lower bound $I^*(f)$. In general, $I_*(f) \leq I^*(f)$.

THEOREM 85. (Darboux criterion) *Let D be a domain with a volume $\text{vol}(D)$ and let $f : D \rightarrow \mathbb{R}$ be a bounded function. Then f is integrable on D if and only if $I_*(f) = I^*(f)$, i.e. if and only if for any $\varepsilon > 0$ there exists a $\delta_{\varepsilon} > 0$ such that if $\|\Delta\| < \delta_{\varepsilon}$ then $S_{\Delta}(f) - s_{\Delta}(f) < \varepsilon$. In*

$$\text{this last case } I_*(f) = I^*(f) = \iiint_D f(x, y, z) dx dy dz.$$

This criterion is very useful whenever we want to prove that a specified class of functions are integrable.

THEOREM 86. *Let D be a closed bounded space domain with ∂D a piecewise smooth surface and let $f : D \rightarrow \mathbb{R}$ be a continuous function defined on D . Then f is integrable on D . If f is continuous on a subset $D \setminus A$ of D such that A has a volume equal to zero, then f is also integrable on D .*

PROOF. We prove only the first statement of the theorem. Since D is closed and bounded, D is a compact subset of \mathbb{R}^3 . Since f is continuous, it is uniformly continuous (see [Po], theorem 59). In order to prove that f is integrable we shall use the above Darboux criterion 85. For this, let us take a small $\varepsilon > 0$. The uniform continuity of f implies that there exists a small $\delta > 0$ (depending on ε) such that if $\mathbf{x}, \mathbf{x}' \in D$ and $\|\mathbf{x} - \mathbf{x}'\| < \delta$, then $|f(\mathbf{x}) - f(\mathbf{x}')| < \frac{\varepsilon}{\text{vol}(D)}$. Let us take a division $\Delta = \{D_i\}$, $i = 1, 2, \dots, n$ of D with $\|\Delta\| < \delta$. Since each D_i is a compact subset of \mathbb{R}^3 and since f is continuous, there exist $\mathbf{x}^{(i)}$ and $\mathbf{x}'^{(i)}$ in D_i with

$$m_i = \inf\{f(x, y, z) : (x, y, z) \in D_i\} = f(\mathbf{x}^{(i)})$$

and

$$M_i = \sup\{f(x, y, z) : (x, y, z) \in D_i\} = f(\mathbf{x}'^{(i)})$$

(see [Po], theorem 58). Hence

$$\begin{aligned} S_\Delta(f) - s_\Delta(f) &= \sum_{i=1}^n [f(\mathbf{x}'^{(i)}) - f(\mathbf{x}^{(i)})] \cdot \text{vol}(D_i) \leq \\ &\leq \sum_{i=1}^n |f(\mathbf{x}'^{(i)}) - f(\mathbf{x}^{(i)})| \cdot \text{vol}(D_i) < \frac{\varepsilon}{\text{vol}(D)} \sum_{i=1}^n \text{vol}(D_i) = \varepsilon, \end{aligned}$$

because $\|\Delta\| < \delta$ implies $\text{diam}(D_i) < \delta$ and so, $\|\mathbf{x}'^{(i)} - \mathbf{x}^{(i)}\| < \delta$. Thus we can apply the uniform continuity of f and finally we get that $S_\Delta(f) - s_\Delta(f) < \varepsilon$, i.e. that f is integrable. \square

REMARK 31. *Up to now we used closed bounded domains D_i with piecewise smooth boundaries, as subdomains of a division Δ of a fixed domain D of the same type. Since any such subdomain D_i can be well approximated with elementary domains (finite union of nonoverlapping parallelepipeds) or with finite unions of nonoverlapping tetrahedrons, balls, prisms, etc., we can substitute these D_i in definition 28 or in theorem 85 with tetrahedrons, balls, prisms, etc. It is clear that in general it is not possible to cover a domain D with nonoverlapping balls, for instance. But, for any small $\varepsilon > 0$, there exists such a union of balls $U_\varepsilon \subset D$, such that $\text{vol}(D \setminus U_\varepsilon) < \varepsilon$. Hence we can work with the following alternative equivalent definition for an integrable function f . We say that $f : D \rightarrow \mathbb{R}$ is (Riemann) integrable on D if there exists a real number I such that for any small $\varepsilon > 0$ and $\eta > 0$ there exists a union $U_\eta = \{B_i\}$ of nonoverlapping balls, such that $U_\eta \subset D$, $\text{vol}(D \setminus U_\eta) < \eta$ and $|I - \sum_{i=1}^n f(\xi_i, \eta_i, \theta_i) \text{vol}(B_i)| < \varepsilon$ for any set of marking points $\{P_i(\xi_i, \eta_i, \theta_i)\}$, $P_i(\xi_i, \eta_i, \theta_i) \in B_i$, $i = 1, 2, \dots, n$. Similarly we can work with tetrahedrons, prisms, general parallelepipeds, etc., instead of balls. This is why if one has a tower of domains like in the formula (2.1),*

$$E_{int}^{(1)} \subset E_{int}^{(2)} \subset \dots \subset E_{int}^{(k)} \subset \dots \subset D,$$

such that $\text{vol}(E_{int}^{(k)}) \nearrow \text{vol}(D)$, then the approximation formulas can be used:

$$(2.2) \quad \iiint_D f(x, y, z) dx dy dz = \lim_{k \rightarrow \infty} \iiint_{E_{int}^{(k)}} f(x, y, z) dx dy dz,$$

or

$$(2.3) \quad \iiint_D f(x, y, z) dx dy dz \approx \iiint_{E_{int}^{(k)}} f(x, y, z) dx dy dz$$

for k large enough. In the engineering practice this last formula is mostly used.

The following result put together some basic properties of the triple integrals.

THEOREM 87. a) the mapping $f \rightsquigarrow \iiint_D f(x, y, z) dx dy dz$ is a linear mapping defined on the vector space $Int(D)$ of all integrable functions defined on D . This means that

$$\begin{aligned} & \iiint_D [\alpha f(x, y, z) + \beta g(x, y, z)] dx dy dz = \\ & = \alpha \iiint_D f(x, y, z) dx dy dz + \beta \iiint_D g(x, y, z) dx dy dz. \end{aligned}$$

b) the mass of a solid (D, f) can be computed as follows:

$$mass(D) = \iiint_D f(x, y, z) dx dy dz.$$

In particular the volume of D is equal to $\iiint_D dx dy dz$.

c) if $f \leq g$ on D , then

$$\iiint_D f(x, y, z) dx dy dz \leq \iiint_D g(x, y, z) dx dy dz.$$

In particular, if $f \geq 0$ on D , then $\iiint_D f(x, y, z) dx dy dz \geq 0$.

$$d) \quad \left| \iiint_D f(x, y, z) dx dy dz \right| \leq \iiint_D |f(x, y, z)| dx dy dz.$$

e)

$$\iiint_D f(x, y, z) dx dy dz = f(x_0, y_0, z_0) \cdot \text{vol}(D),$$

where f is continuous and (x_0, y_0, z_0) is a point of D (mean formula). This formula says that any nonhomogeneous solid has the same mass as a homogenous solid with the same domain D and the constant density equal to the value of the initial density function at a certain point of D . In particular, if f is continuous, $f(x, y, z) \geq 0$ and

$$\iiint_D f(x, y, z) dx dy dz > 0,$$

then f is not zero on a small ball which is contained in D . Moreover, if $f \geq 0$ and

$$\iiint_D f(x, y, z) dx dy dz = 0,$$

then the set A of points (x, y, z) for which $f(x, y, z) > 0$ has the volume equal to zero (the proof of this statement is more difficult).

f) if $\Delta = \{D_i\}$, $i = 1, 2, \dots, n$ is a division of D , then

$$\iiint_D f(x, y, z) dx dy dz = \sum_{i=1}^n \iiint_{D_i} f(x, y, z) dx dy dz.$$

All the other applications which we met in the case of a triple integral on parallelepipeds can be deduced here for a general domain D . For instance, the coordinates of the mass centre of a solid (D, f) are:

$$(2.4) \quad x_G = \frac{\iiint_D x f(x, y, z) dx dy dz}{\iiint_D f(x, y, z) dx dy dz}, \quad y_G = \frac{\iiint_D y f(x, y, z) dx dy dz}{\iiint_D f(x, y, z) dx dy dz},$$

$$z_G = \frac{\iiint_D z f(x, y, z) dx dy dz}{\iiint_D f(x, y, z) dx dy dz}.$$

If our solid (D, f) is rotating around the Oz -axis for instance, the inertia moment can be computed as follows:

$$I_z = \iiint_D (x^2 + y^2) f(x, y, z) dx dy dz,$$

because the square of the distance of a point $M(x, y, z)$ up to the Oz -axis is equal to $x^2 + y^2$. The reader can easily deduce other formulae if one knows such a formula for a point with a "mass" at it. For instance, a solid (D, f) is moving around a straight line (d) and the distance of a point $M(x, y, z)$ of this solid up to the line (d) is a function $H(x, y, z)$. Then, the inertia moment of this single point is equal to $H^2(x, y, z) \cdot f(x, y, z)$. Now we "globalize" this last relation and obtain a general formula for the inertia moment of the entire solid, when it is rotating around the line (d) :

$$I_{(d)} = \iiint_D H^2(x, y, z) \cdot f(x, y, z) dx dy dz.$$

Since we have no effective method to compute a triple integral up to the present time, we postpone to work with some examples. Thus we continue our study by presenting the basic method of computation of the triple integrals, namely the "iterative method". The name comes from the fact that by using this method we shall reduce the computation of a triple integral to the successive (iterative) calculation of three simple Riemann integrals.

3. Iterative formulas for a general space domain

Let us begin with some prerequisites.

We say that a surface (S) is *explicitly (described)* with respect to z if it has a parametrization of the following type:

$$(S) : \begin{cases} x = x \\ y = y \\ z = z(x, y) \end{cases}, (x, y) \in \Omega = pr_{xOy}(S),$$

the projection of (S) on the xOy -plane (see Fig.4).

A domain D is *simple w.r.t. Oz-axis* if there exist two continuous functions $z = \varphi(x, y)$ and $z = \psi(x, y)$ such that:

$$D = \{M(x, y, z) : \varphi(x, y) \leq z \leq \psi(x, y), \text{ where } (x, y) \in \Omega \subset xOy\},$$

i.e. D is the "continuous" union of all segments

$$[M_1(x, y, \varphi(x, y)), M_2(x, y, \psi(x, y))],$$

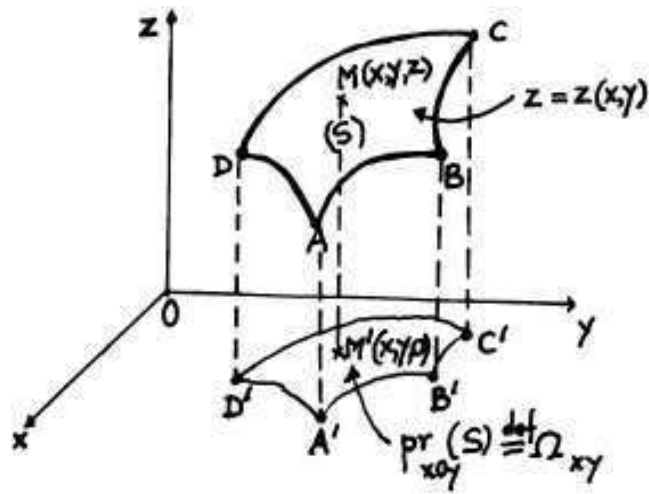

FIGURE 4

when (x, y) runs on a plane domain Ω contained in the xOy -plane (see Fig.5). This means that D is a cylindrical domain delimited "up and down" by the explicitly described surfaces $z = \varphi(x, y)$ and $z = \psi(x, y)$.

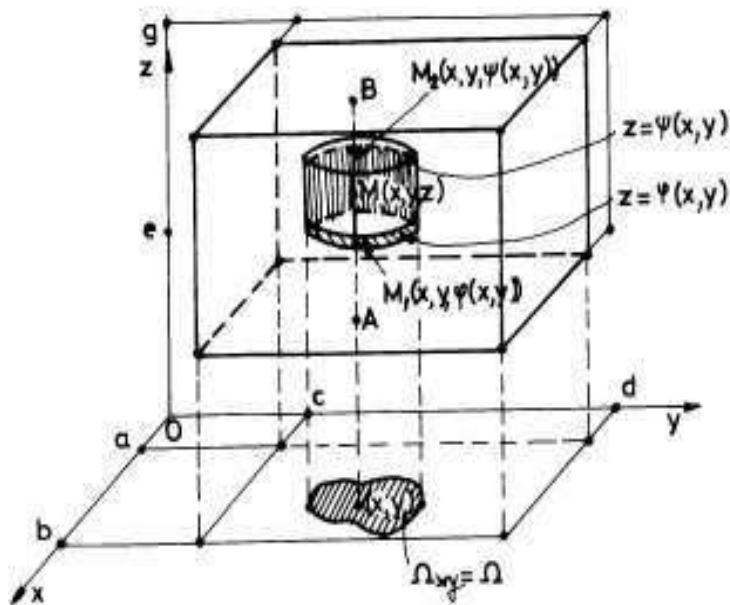

FIGURE 5

THEOREM 88. (a general iterative formula I) Let D be a general domain (see its definition at the beginning of this section) in \mathbb{R}^3 and let (D, f) be a solid ($f : D \rightarrow \mathbb{R}$ is a piecewise continuous function). We also assume that D is simple w.r.t. Oz -axis. Then:

$$(3.1) \quad \iiint_D f(x, y, z) dx dy dz = \iint_{\Omega} \left[\int_{\varphi(x, y)}^{\psi(x, y)} f(x, y, z) dz \right] dx dy.$$

This formula says that first of all we compute a simple integral

$$J(x, y) = \int_{\varphi(x, y)}^{\psi(x, y)} f(x, y, z) dz,$$

with two parameters x and y , on the segment

$$[M_1(x, y, \varphi(x, y)), M_2(x, y, \psi(x, y))],$$

relative to the variable z . Then, we compute a double integral

$$\iint_{\Omega} J(x, y) dx dy$$

of the just obtained function $J(x, y)$, on the domain

Ω , the projection of D on the xOy -plane (see Fig.5).

PROOF. In order not to lose ourselves in sophisticated technical considerations and to escape the essential, we prove this result only when f is continuous. The idea of the proof is like the idea used for proving a similar formula for a double integral (see theorem 79). Let us construct the following three segments: $[a, b] = pr_{Ox}(D)$, $[c, d] = pr_{Oy}(D)$ and $[e, g] = pr_{Oz}(D)$, the projections of the domain D on the three coordinates axes. Let us denote by $E = [a, b] \times [c, d] \times [e, g]$, the parallelepiped constructed with these last segments. It is clear that $D \subset E$ (see Fig.5). It is "clear" that if we extend the density function $f : D \rightarrow \mathbb{R}$ to E by putting the density zero at all the points of E which are not in D , the mass of D will be the same as the mass of E . Indeed, let us define $\tilde{f} : E \rightarrow \mathbb{R}$,

$$\tilde{f}(x, y, z) = \begin{cases} f(x, y, z), & \text{if } (x, y, z) \in D, \\ 0, & \text{if } (x, y, z) \in E \setminus D. \end{cases}$$

Since f is continuous on D , \tilde{f} is discontinuous (but bounded!) at most on ∂D , which is a finite union of smooth bounded surfaces. Hence, the set of points at which \tilde{f} is discontinuous has volume zero. This means that \tilde{f} is integrable on E and we can apply to its triple integral the

iterative formula (1.2):

$$\begin{aligned}
\iiint_D f(x, y, z) dx dy dz &= \iiint_E \tilde{f}(x, y, z) dx dy dz = \\
&= \int_a^b \left(\int_c^d \left(\int_e^g \tilde{f}(x, y, z) dz \right) dy \right) dx = \\
&= \int_{[a,b] \times [c,d]} \left(\int_e^{\varphi(x,y)} \tilde{f}(x, y, z) dz + \int_{\varphi(x,y)}^{\psi(x,y)} \tilde{f}(x, y, z) dz + \right. \\
&+ \left. \int_{\psi(x,y)}^g \tilde{f}(x, y, z) dz \right) dx dy = \int_{[a,b] \times [c,d]} \left(\int_{\varphi(x,y)}^{\psi(x,y)} \tilde{f}(x, y, z) dz \right) dx dy = \\
&= \iint_{\Omega} \left(\int_{\varphi(x,y)}^{\psi(x,y)} f(x, y, z) dz \right) dx dy,
\end{aligned}$$

i.e. we just obtained the iterative formula (3.1). Here we used the fact that $\tilde{f}(x, y, z) = 0$ at all the points of the segment $[A, B]$ which are outside of the segment $[M_1 M_2]$ and, at all the points of E which are projected on the xOy -plane in the points of the region $[a, b] \times [c, d] \setminus \Omega$ (see Fig.5). For the other points (x, y, z) of D , $\tilde{f}(x, y, z) = f(x, y, z)$. \square

EXAMPLE 87. Let $\Omega = \{M(x, y, z) : x^2 + y^2 \leq z^2, 0 \leq z \leq 2\}$ be the conic domain from Fig.6 and let $f(x, y, z) = 3z$ be a density function defined on Ω . Let us compute the mass of the solid (Ω, f) .

We must be careful here because Ω is not more a plane domain like in the above theorem. Hence $\varphi(x, y) = \sqrt{x^2 + y^2}$ and $\psi(x, y) = 2$ and for Ω of the above theorem one has $\Omega_{xy} = pr_{xOy}(D)$ (see Fig.6).

Thus, using formula 3.1, we get:

$$\begin{aligned}
mass(\Omega) &= \iiint_{\Omega} 3z dx dy dz = \int \int_{x^2+y^2 \leq 4} \left(\int_{\sqrt{x^2+y^2}}^2 3z dz \right) dx dy = \\
&= \frac{3}{2} \int \int_{x^2+y^2 \leq 4} z^2 \Big|_{\sqrt{x^2+y^2}}^2 dx dy = \frac{3}{2} \int \int_{x^2+y^2 \leq 4} [4 - (x^2 + y^2)] dx dy = \\
&= 6 \int \int_{x^2+y^2 \leq 4} dx dy - \frac{3}{2} \int \int_{x^2+y^2 \leq 4} (x^2 + y^2) dx dy.
\end{aligned}$$

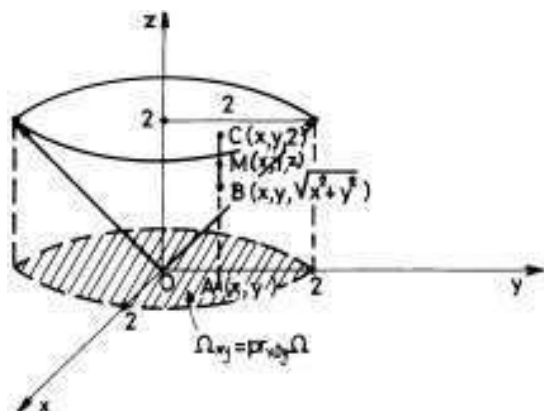

FIGURE 6

The first double integral is nothing else than 6 times the area of a disc with radius 2, thus its value is equal to 24π . Let us use polar coordinates change of variables to compute the second double integral:

$$\begin{aligned} \int_{x^2+y^2 \leq 4} (x^2 + y^2) dx dy &= \int_0^2 \left(\int_0^{2\pi} \rho^2 \cdot \rho d\theta \right) d\rho = \\ &= \int_0^2 \rho^3 \left(\int_0^{2\pi} d\theta \right) d\rho = 2\pi \left. \frac{\rho^4}{4} \right|_0^2 = 8\pi. \end{aligned}$$

Hence,

$$\text{mass}(\Omega) = 24\pi - \frac{3}{2} \cdot 8\pi = 12\pi.$$

We see that in the above iterative formula first of all one computes a simple integral and then one computes a double integral. We shall see in the following that in some cases it is possible to compute firstly a double integral and then a simple one. Moreover, in the next result the general domain D which appeared in the statement of theorem 88 needs not to be simple.

THEOREM 89. (a general iterative formula II) Let Ω be a general domain and let (Ω, f) be a solid such that $[e, g] = \text{pr}_{Oz}(\Omega)$, $S = \Omega \cap \{Z = z\}$, where $z \in [e, g]$, is the section of Ω realized by the plane $Z = z$ and Ω_z is the projection of S on the xOy -plane (see Fig. 7). Then,

$$(3.2) \quad \iiint_{\Omega} f(x, y, z) dx dy dz = \int_e^g \left(\iint_{\Omega_z} f(x, y, z) dx dy \right) dz.$$

Here, first of all we compute a double integral $I(z) = \iint_{\Omega_z} f(x, y, z) dx dy$ with a parameter z and then we calculate a simple integral $\int_e^g I(z) dz$ of the last computed function $I(z)$.

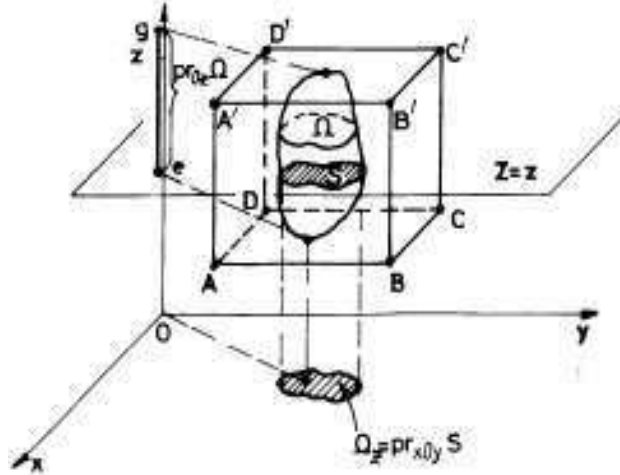

FIGURE 7

PROOF. To avoid some nonessential technical tricks, we assume that $f : \Omega \rightarrow \mathbb{R}$ is a continuous function. Let $E = [ABCD A' B' C' D'] = [a, b] \times [c, d] \times [e, g]$ be a parallelepiped which contains Ω and

$$\tilde{f}(x, y, z) = \begin{cases} f(x, y, z), & \text{if } (x, y, z) \in \Omega, \\ 0, & \text{if } (x, y, z) \in E \setminus \Omega. \end{cases}$$

be a density function on E which extend f up to E . It is easy to see that the mass of (E, \tilde{f}) is equal to the mass of (Ω, f) . Applying the iterative formula (1.2) for the parallelepiped domain E , we get:

$$\begin{aligned} \iiint_{\Omega} f(x, y, z) dx dy dz &= \iiint_E \tilde{f}(x, y, z) dx dy dz = \\ &= \int_e^g \left(\iint_{[a,b] \times [c,d]} \tilde{f}(x, y, z) dx dy \right) dz = \int_e^g \left(\iint_{\Omega_z} f(x, y, z) dx dy \right) dz, \end{aligned}$$

because $\tilde{f}(x, y, z) = 0$, when (x, y) is in $[a, b] \times [c, d]$ but not in Ω_z and $\tilde{f}(x, y, z) = f(x, y, z)$, when $(x, y) \in \Omega_z$. \square

EXAMPLE 88. The solid (Ω, f) , where $\Omega : x^2 + y^2 \leq z^2, 0 \leq z \leq 2$ and $f(x, y, z) = z^2$ is rotating around Oz -axis. Let us compute the inertia moment of it w.r.t. to Oz -axis (see Fig.8). The projection of the domain Ω on the Oz -axis is the segment $[0, 2]$. For any $z_0 \in [0, 2]$, the projection of the section of Ω determined by the plane $Z = z_0$ is the disc $\Omega_{z_0} : x^2 + y^2 \leq z_0^2$. Let us apply now the formula (3.2) to compute

the triple integral $I_z = \iiint_{\Omega} z^2(x^2 + y^2) dx dy dz$.

$$\begin{aligned} I_z &= \iiint_{\Omega} z^2(x^2 + y^2) dx dy dz = \int_0^2 z^2 \left(\int_{x^2+y^2 \leq z^2} (x^2 + y^2) dx dy \right) dz = \\ &= \int_0^2 z^2 \left[\int_0^z \rho^3 \left(\int_0^{2\pi} d\theta \right) d\rho \right] dz = 2\pi \int_0^2 z^2 \cdot \frac{z^4}{4} dz = \frac{\pi}{2} \cdot \frac{z^7}{7} \Big|_0^2 = \frac{64\pi}{7}. \end{aligned}$$

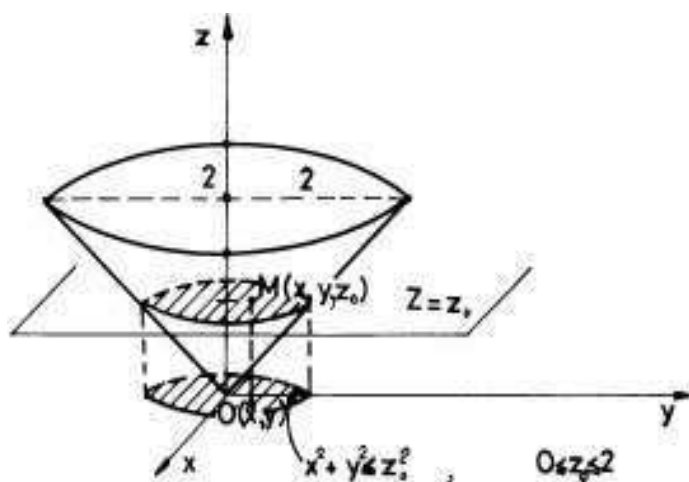

FIGURE 8

Both iterative formulas (3.1) and (3.2) refers to the Oz -axis. We can easily imagine the other four types of formulas which refer to Oy -axis and to Ox -axis.

EXAMPLE 89. For instance, let us find the coordinates of the mass centre of the domain $D : x^2 + z^2 \leq 2y, 0 \leq y \leq 8$ and the density function $f(x, y, z) = y$. The matter is about a circular paraboloidal domain with Oy as an axe of symmetry. The symmetry here is also a static symmetry because the mass is symmetrically distributed w.r.t.

the Oy -axis. Indeed, $f(-x, y, -z) = y = f(x, y, z)$, i.e. the density of the point $M(x, y, z)$ is the same as the density of its symmetric point $M'(-x, y, -z)$ w.r.t. Oy -axis. Thus, the mass centre G is on the Oy -axis, i.e. $x_G = z_G = 0$. Let us compute

$$y_G = \frac{\iiint_D y \cdot y dx dy dz}{\iiint_D y dx dy dz}.$$

Let us firstly compute $I = \iiint_D y dx dy dz$, the mass of the solid. Let us use the first iterative formula (3.1). The projection of the domain on the zOx -plane is the disc: $x^2 + z^2 \leq 16$, with radius equal to 4. For a fixed point $P(x, 0, z)$ in this last disc, all the points of D which are projecting in P are the points of the space segment

$$[M_1(x, \frac{x^2 + z^2}{2}, z), M_2(x, 8, z)].$$

Thus,

$$\begin{aligned} \iiint_D y dx dy dz &= \int \int_{x^2+z^2 \leq 16} \left(\int_{\frac{x^2+z^2}{2}}^8 y dy \right) dx dz = \\ &= \frac{1}{2} \int \int_{x^2+z^2 \leq 16} \left[y^2 \Big|_{\frac{x^2+z^2}{2}}^8 \right] dx dz = \frac{1}{2} \int \int_{x^2+z^2 \leq 16} \left[64 - \frac{(x^2 + z^2)^2}{4} \right] dx dz = \\ &= 32 \int \int_{x^2+z^2 \leq 16} dx dz - \frac{1}{8} \int \int_{x^2+z^2 \leq 16} (x^2 + z^2)^2 dx dz. \end{aligned}$$

The first integral is 32 times the area of a disc of radius 4, i.e. it is equal to $32 \times \pi \times 16$. Let us compute the second double integral

$$\int \int_{x^2+z^2 \leq 16} (x^2 + z^2)^2 dx dz = \int_0^4 \left(\int_0^{2\pi} \rho^4 \cdot \rho d\theta \right) d\rho = 2\pi \frac{\rho^6}{6} \Big|_0^4 = \pi \frac{4^6}{3}.$$

Hence, the mass of D is equal to $32 \times \pi \times 16 - \pi \frac{4^6}{6} = \frac{4^5 \pi}{3}$.

Let us now compute the static moment w.r.t. xOz -plane,

$$J = \iiint_D y^2 dx dy dz = \int \int_{x^2+z^2 \leq 16} \left(\int_{\frac{x^2+z^2}{2}}^8 y^2 dy \right) dx dz =$$

$$\begin{aligned}
&= \frac{1}{3} \int \int_{x^2+z^2 \leq 16} \left[y^3 \left| \frac{8}{x^2+z^2} \right| \right] dx dz = \frac{1}{3} \int \int_{x^2+z^2 \leq 16} \left[8^3 - \frac{(x^2+z^2)^3}{8} \right] dx dz = \\
&= \frac{8^3}{3} \int \int_{x^2+z^2 \leq 16} dx dz - \frac{1}{24} \int \int_{x^2+z^2 \leq 16} (x^2+z^2)^3 dx dz = \\
&= \frac{8^3}{3} \cdot 16\pi - \frac{1}{24} \int_0^4 \left(\int_0^{2\pi} \rho^6 \cdot \rho d\theta \right) d\rho = \\
&= \frac{8^3}{3} \cdot 16\pi - \frac{1}{24} \cdot 2\pi \cdot \frac{\rho^8}{8} \Big|_0^4 = \frac{8^3}{3} \cdot 16\pi - \frac{1}{24} \cdot 2\pi \cdot \frac{4^8}{8} = \\
&= \frac{1}{24 \cdot 8} (8^5 \cdot 16\pi - 4^8 \cdot 2\pi) = 2\pi \cdot 4^5.
\end{aligned}$$

Hence, $y_G = \frac{2\pi \cdot 4^5}{4^5 \pi} = 6$.

4. Change of variables in a triple integral

Let us consider two general space domain Ω and D , both in \mathbb{R}^3 , the first described relative to a Cartesian coordinate system $\{ou, ov, ow\}$ and the second relative to the usual Cartesian coordinate system

$\{Ox, Oy, Oz\}$. Recall that a general space domain D is a closed, bounded and connected subset D of \mathbb{R}^3 such that its boundary ∂D is a piecewise smooth surface. A *smooth deformation* from Ω to D is a vector function $\vec{g} : \Omega \rightarrow D$, $\vec{g}(u, v, w) = (x(u, v, w), y(u, v, w), z(u, v, w))$ which is a diffeomorphism, i.e. it is a bijection and \vec{g} and its inverse $\vec{g}^{-1} : D \rightarrow \Omega$ are vector functions (fields) of class C^1 . Here x, y, z are independent variables, but $x(u, v, w), y(u, v, w), z(u, v, w)$ are three functions of three independent variables u, v and w . We prefer not to introduce new notation for the name of these three last functions (like $\varphi(u, v, w), \psi(u, v, w), \theta(u, v, w)$). A change of the "old" variables x, y and z with the "new" ones u, v and w is nothing else then such a smooth deformation or a "regular transformation", another more mathematical term for the same notion.

First of all we are interested how changes the volume of a small (its diameter is small enough!) parallelepiped domain $[P_0P_1P_4P_3P_2P'_1P'_4P'_3]$ of the domain Ω , which contains a fixed marking point $P(\xi, \eta, \theta)$, through the deformation \vec{g} . Let $[M_0M_1M_4M_3M_2M'_1M'_4M'_3]$ be the image

$\vec{g}([P_0P_1P_4P_3P_2P'_1P'_4P'_3])$ of $[P_0P_1P_4P_3P_2P'_1P'_4P'_3]$ through \vec{g} (see Fig.9).

If $P_0(u_0, v_0, w_0), P_1(u_0, v_1, w_0), P_2(u_0, v_0, w_1), P_3(u_1, v_0, w_0),$

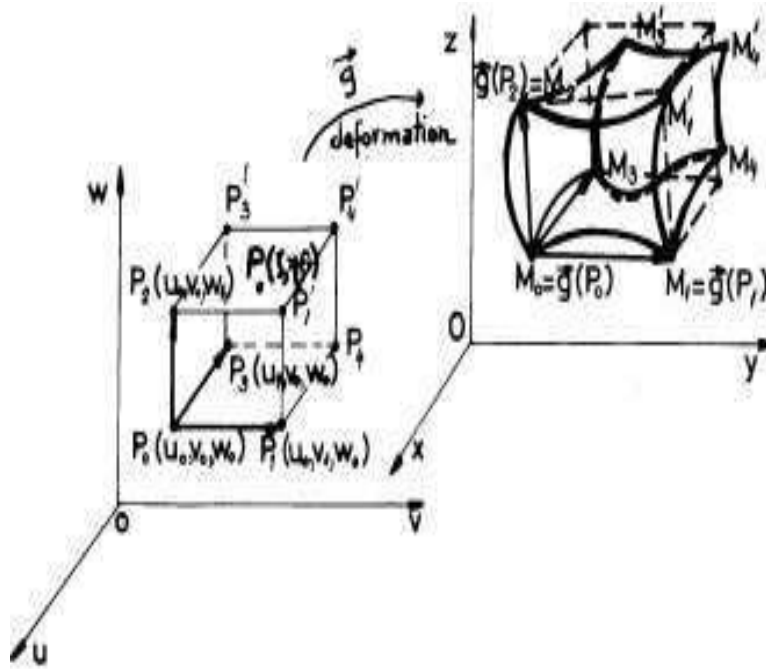

FIGURE 9

$M_0(x_0, y_0, z_0)$, $M_1(x_1, y_1, z_1)$, $M_2(x_2, y_2, z_2)$ and $M_3(x_3, y_3, z_3)$ then,

$$(4.1) \quad \begin{cases} x_0 = x(u_0, v_0, w_0) \\ y_0 = y(u_0, v_0, w_0) \\ z_0 = z(u_0, v_0, w_0) \end{cases}, \begin{cases} x_1 = x(u_0, v_1, w_0) \\ y_1 = y(u_0, v_1, w_0) \\ z_1 = z(u_0, v_1, w_0) \end{cases},$$

$$\begin{cases} x_2 = x(u_0, v_0, w_1) \\ y_2 = y(u_0, v_0, w_1) \\ z_2 = z(u_0, v_0, w_1) \end{cases}, \begin{cases} x_3 = x(u_1, v_0, w_0) \\ y_3 = y(u_1, v_0, w_0) \\ z_3 = z(u_1, v_0, w_0) \end{cases}.$$

THEOREM 90. (the change of an elementary volume) With the above notation and hypotheses, one has that:

$$(4.2) \quad \text{vol}([M_0M_1M_4M_3M_2M_1'M_4'M_3']) \approx$$

$$(4.3) \quad |J_{\vec{g}}(\xi, \eta, \theta)| \text{vol}([P_0P_1P_4P_3P_2P_1'P_4'P_3']) =$$

$$= |J_{\vec{g}}(\xi, \eta, \theta)| (u_1 - u_0)(v_1 - v_0)(w_1 - w_0).$$

The approximation means that the volume of the image of the parallelepiped

$$[P_0P_1P_4P_3P_2P_1'P_4'P_3']$$

through the deformation \vec{g} is closer and closer to the quantity

$$|J_{\vec{g}}(\xi, \eta, \theta)| (u_1 - u_0)(v_1 - v_0)(w_1 - w_0)$$

as soon as the diameter of the parallelepiped is smaller and smaller. Hence, we can look at the quantity $|J_{\vec{g}}(\xi, \eta, \theta)|$ as to a local "dilation" or "contraction" coefficient of our deformation \vec{g} . It controls the modification of small volumes during the deformation process.

PROOF. The following sequence of consecutive approximations will give us the final approximation of the formula (4.2).

$$(4.4) \quad \text{vol}([M_0M_1M_4M_3M_2M'_1M'_4M'_3]) \approx \text{vol} \left(\left[\overrightarrow{M_0M_1}, \overrightarrow{M_0M_2}, \overrightarrow{M_0M_3} \right] \right),$$

where $\left[\overrightarrow{M_0M_1}, \overrightarrow{M_0M_2}, \overrightarrow{M_0M_3} \right]$ is the skew general parallelepiped constructed with the vectors $\overrightarrow{M_0M_1}, \overrightarrow{M_0M_2}, \overrightarrow{M_0M_3}$. Let us remember, from any course of Vector Calculus, the basic formula of calculation of such a volume. It is in fact the absolute value of the mixed product

$$(\overrightarrow{M_0M_1}, \overrightarrow{M_0M_2}, \overrightarrow{M_0M_3}),$$

which is computed as the value of the following determinant:

$$(4.5) \quad \det \begin{pmatrix} x_1 - x_0 & y_1 - y_0 & z_1 - z_0 \\ x_2 - x_0 & y_2 - y_0 & z_2 - z_0 \\ x_3 - x_0 & y_3 - y_0 & z_3 - z_0 \end{pmatrix}.$$

Since $x_1 = x(u_0, v_1, w_0)$ and $x_0 = x(u_0, v_0, w_0)$, let us consider the function $v \rightsquigarrow x(u_0, v, w_0)$ and let us apply to it Lagrange formula (see [Po], Corollary 5, pag.88) on the interval $[v_0, v_1]$:

$$x_1 - x_0 = \frac{\partial x}{\partial v}(u_0, c, w_0) \cdot (v_1 - v_0),$$

where $c \in (v_0, v_1)$. Since the diameter of the parallelepiped

$[P_0P_1P_4P_3P_2P'_1P'_4P'_3]$ is very small, the point (u_0, c, w_0) is very closed to $P(\xi, \eta, \theta)$. Since the functions $x(u, v, w), y(u, v, w), z(u, v, w)$ are of class C^1 , the function $\frac{\partial x}{\partial v}(u, v, w)$ is continuous. Hence $\frac{\partial x}{\partial v}(u_0, c, w_0)$ is sufficiently close to $\frac{\partial x}{\partial v}(\xi, \eta, \theta)$. Finally we get the approximation:

$$(4.6) \quad x_1 - x_0 \approx \frac{\partial x}{\partial v}(\xi, \eta, \theta) \cdot (v_1 - v_0)$$

The same type of reasoning lead us to the other approximations:

$$\begin{aligned} y_1 - y_0 &\approx \frac{\partial y}{\partial v}(\xi, \eta, \theta) \cdot (v_1 - v_0), \\ z_1 - z_0 &\approx \frac{\partial z}{\partial v}(\xi, \eta, \theta) \cdot (v_1 - v_0), \end{aligned}$$

$$\begin{aligned}
x_2 - x_0 &\approx \frac{\partial x}{\partial w}(\xi, \eta, \theta) \cdot (w_1 - w_0), \\
y_2 - y_0 &\approx \frac{\partial y}{\partial w}(\xi, \eta, \theta) \cdot (w_1 - w_0), \\
z_2 - z_0 &\approx \frac{\partial z}{\partial w}(\xi, \eta, \theta) \cdot (w_1 - w_0), \\
x_3 - x_0 &\approx \frac{\partial x}{\partial u}(\xi, \eta, \theta) \cdot (u_1 - u_0), \\
y_3 - y_0 &\approx \frac{\partial y}{\partial u}(\xi, \eta, \theta) \cdot (u_1 - u_0), \\
z_3 - z_0 &\approx \frac{\partial z}{\partial u}(\xi, \eta, \theta) \cdot (u_1 - u_0).
\end{aligned}$$

With these approximations, we come back to the above determinant (4.5) and find:

$$\begin{aligned}
&\det \begin{pmatrix} x_1 - x_0 & y_1 - y_0 & z_1 - z_0 \\ x_2 - x_0 & y_2 - y_0 & z_2 - z_0 \\ x_3 - x_0 & y_3 - y_0 & z_3 - z_0 \end{pmatrix} \approx \\
&\approx \det \begin{pmatrix} \frac{\partial x}{\partial v}(\xi, \eta, \theta) & \frac{\partial y}{\partial v}(\xi, \eta, \theta) & \frac{\partial z}{\partial v}(\xi, \eta, \theta) \\ \frac{\partial x}{\partial w}(\xi, \eta, \theta) & \frac{\partial y}{\partial w}(\xi, \eta, \theta) & \frac{\partial z}{\partial w}(\xi, \eta, \theta) \\ \frac{\partial x}{\partial u}(\xi, \eta, \theta) & \frac{\partial y}{\partial u}(\xi, \eta, \theta) & \frac{\partial z}{\partial u}(\xi, \eta, \theta) \end{pmatrix} (u_1 - u_0)(v_1 - v_0)(w_1 - w_0).
\end{aligned}$$

Since the determinant of a transposed matrix is the same like the determinant of the initial matrix and since by changing the rows between them, the absolute value of the obtained determinant does not change, we finally get that the absolute value of this last value is nothing else then

$$|J_{\vec{g}}(\xi, \eta, \theta)| (u_1 - u_0)(v_1 - v_0)(w_1 - w_0),$$

i.e. the formula which appeared in the statement of the theorem. Let us recall the definition of the Jacobian of \vec{g} :

$$(4.7) \quad J_{\vec{g}}(\xi, \eta, \theta) = \det \begin{pmatrix} \frac{\partial x}{\partial u}(\xi, \eta, \theta) & \frac{\partial x}{\partial v}(\xi, \eta, \theta) & \frac{\partial x}{\partial w}(\xi, \eta, \theta) \\ \frac{\partial y}{\partial u}(\xi, \eta, \theta) & \frac{\partial y}{\partial v}(\xi, \eta, \theta) & \frac{\partial y}{\partial w}(\xi, \eta, \theta) \\ \frac{\partial z}{\partial u}(\xi, \eta, \theta) & \frac{\partial z}{\partial v}(\xi, \eta, \theta) & \frac{\partial z}{\partial w}(\xi, \eta, \theta) \end{pmatrix}$$

□

Let us use this basic result in order to prove the next theorem. We shall again use the following simple observation: if two real numbers I and J are limit points for one and the same subset A of real numbers and if A has a unique limit point, then $I = J$. Instead of saying that I is a limit point of A , we can say that I can be well approximated with elements of A , etc.

THEOREM 91. (*general change of variables in triple integrals*) With the above notation and hypotheses one has:

$$(4.8) \quad \begin{aligned} & \iiint_D f(x, y, z) dx dy dz = \\ & = \iiint_{\Omega} f(x(u, v, w), y(u, v, w), z(u, v, w)) \cdot |J_{\vec{g}}(u, v, w)| dudvdw. \end{aligned}$$

PROOF. We can well approximate the domain Ω with a union of nonoverlapping (which have no interior common points) parallelepipeds $\Omega_{ijk} = [u_{i-1}, u_i] \times [v_{j-1}, v_j] \times [w_{k-1}, w_k]$, $i = 1, 2, \dots, n$, $j = 1, 2, \dots, m$, $k = 1, 2, \dots, p$. Let $D_{ijk} = \vec{g}(\Omega_{ijk})$ be the image of Ω_{ijk} after the deformation \vec{g} . Since \vec{g} is a diffeomorphism, D can also be well approximated by the set of subdomains $\{D_{ijk}\}$, $i = 1, 2, \dots, n$, $j = 1, 2, \dots, m$, $k = 1, 2, \dots, p$.

Let $\{P_{ijk}(\xi_i, \eta_j, \theta_k)\}$, $P_{ijk} \in \Omega_{ijk}$, be a set of marking points in Ω (Pay attention, $\{\Omega_{ijk}\}$ is not a division of Ω). We just remarked above (see remark 31) that the triple integral $I = \iiint_D f(x, y, z) dx dy dz$ can

be well approximated by sums of the following type (here

$$\begin{aligned} M_{ijk}(x(\xi_i, \eta_j, \theta_k), y(\xi_i, \eta_j, \theta_k), z(\xi_i, \eta_j, \theta_k)) & \in D_{ijk}, \\ i = 1, 2, \dots, n, j = 1, 2, \dots, m, k = 1, 2, \dots, p \end{aligned}$$

is a set of marking points in D):

$$(4.9) \quad I \approx \sum_{i=1}^n \sum_{j=1}^m \sum_{k=1}^p f(x(\xi_i, \eta_j, \theta_k), y(\xi_i, \eta_j, \theta_k), z(\xi_i, \eta_j, \theta_k)) \cdot \text{vol}(D_{ijk}).$$

But, using formula (4.2), we get: $\text{vol}(D_{ijk}) \approx |J_{\vec{g}}(\xi_i, \eta_j, \theta_k)| (u_i - u_{i-1})(v_j - v_{j-1})(w_k - w_{k-1})$. Thus, coming back to formula (4.9), we get:

$$\begin{aligned} I \approx & \sum_{i=1}^n \sum_{j=1}^m \sum_{k=1}^p f(x(\xi_i, \eta_j, \theta_k), y(\xi_i, \eta_j, \theta_k), z(\xi_i, \eta_j, \theta_k)) \times \\ & \times |J_{\vec{g}}(\xi_i, \eta_j, \theta_k)| (u_i - u_{i-1})(v_j - v_{j-1})(w_k - w_{k-1}), \end{aligned}$$

which is a sum that well approximates the triple integral

$$J = \iiint_{\Omega} f(x(u, v, w), y(u, v, w), z(u, v, w)) \cdot |J_{\vec{g}}(u, v, w)| dudvdw.$$

Since I and J are fixed numbers and since $I \approx J$ as well as we want, we must conclude that $I = J$, i.e. the required equality in formula (4.8). \square

REMARK 32. When we want to use the change of variables formula (4.8), first of all we must try to realize our domain D as the image of a simpler domain Ω , a parallelepiped if this is possible, through a smooth deformation \vec{g} . Even $\vec{g} : \Omega \rightarrow D$ is not more a diffeomorphism, but it is so whenever we restrict it to an open subset $\Omega' \subset \Omega$ with $\text{vol}(\Omega \setminus \Omega') = 0$ and the subset $D \setminus \vec{g}(\Omega')$ has volume zero, the change of variables formula continues to work. Indeed,

$$\begin{aligned} \iiint_D f(x, y, z) dx dy dz &= \iint_{D \setminus \vec{g}(\Omega')} \int f(x, y, z) dx dy dz + \\ &+ \iint_{\vec{g}(\Omega')} \int f(x, y, z) dx dy dz = 0 + \iint_{\vec{g}(\Omega')} \int f(x, y, z) dx dy dz = \\ &= \iiint_{\Omega'} f(x(u, v, w), y(u, v, w), z(u, v, w)) \cdot |J_{\vec{g}}(u, v, w)| du dv dw = \\ &= \iiint_{\Omega} f(x(u, v, w), y(u, v, w), z(u, v, w)) \cdot |J_{\vec{g}}(u, v, w)| du dv dw. \end{aligned}$$

Here we used an immediate result (prove it!): "The integral (simple, double, triple, etc.) on a subset of measure (length, area, volume, etc.) zero is always equal to zero. Indeed, look carefully to any general Riemann sum, ... it is zero!"

REMARK 33. Moreover, during the proof of the above theorem 91 we did not use the fact that D or Ω are closed. Even some parts of their boundaries ∂D or $\partial \Omega$ are missing, the formula continues to work. This will be the situation in some future applications, when either the Jacobian $J_{\vec{g}}$ is zero at some points of $\partial \Omega$, or \vec{g} is not a bijection or a diffeomorphism around some points of Ω (see below the change of the Cartesian coordinates x, y, z into the spherical coordinates ρ, φ, θ).

EXAMPLE 90. Let D be the skew parallelepiped $[OACBDA'C'B']$ generated by the vectors $\vec{OA} = \vec{i} + 3\vec{j} + \vec{k}$, $\vec{OB} = -3\vec{i} + \vec{k}$ and $\vec{OD} = \vec{i} + \vec{j} + 4\vec{k}$ (see Fig.10).

Assume that D is loaded with a density function $f(x, y, z) = x + y + z$. Let us compute the mass of D , i.e. the triple integral $I =$

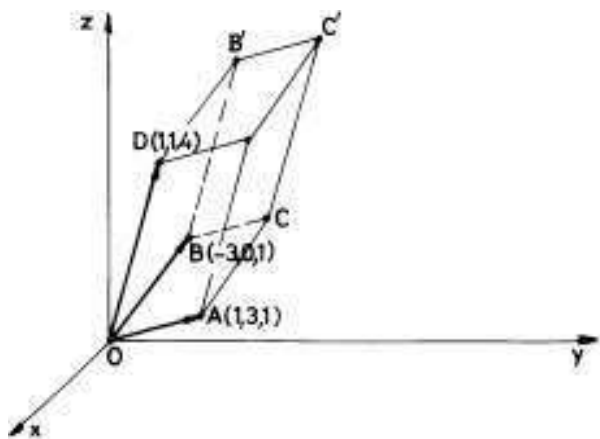

FIGURE 10

$\iiint_D f(x, y, z) dx dy dz$. We see that any of the iterative methods fails in this case because of the "complicated" geometrical form of D (it can also be divided into "many" simple subdomains w.r.t. Oz -axis). Let us use the change of variables method described above. For this, we try to find a linear transformation $\vec{g} : \mathbb{R}^3 \rightarrow \mathbb{R}^3$ such that the image of the cube $\Omega = [0, 1] \times [0, 1] \times [0, 1]$ through \vec{g} be exactly our domain D . Any course of Linear Algebra tells us that there exists one and only one linear transformation (an isomorphism or automorphism in fact!) which changes the basis $\{(1, 0, 0), (0, 1, 0), (0, 0, 1)\}$ into another basis $\{\vec{OA}, \vec{OB}, \vec{OD}\}$. Here we just identified the arithmetical vector space \mathbb{R}^3 with the geometrical 3-D space V_3 of all free space vectors. It is easy to write the matrix $M_{\vec{g}}$ of this linear transformation w.r.t. the canonical basis $\{(1, 0, 0), (0, 1, 0), (0, 0, 1)\}$ of \mathbb{R}^3 :

$$M_{\vec{g}} = \begin{pmatrix} 1 & -3 & 1 \\ 3 & 0 & 1 \\ 1 & 1 & 4 \end{pmatrix}.$$

Thus, \vec{g} acts on the column vector $(u, v, w)^t \in \mathbb{R}^3$ as follows:

$$\vec{g} \begin{pmatrix} u \\ v \\ w \end{pmatrix} = \begin{pmatrix} 1 & -3 & 1 \\ 3 & 0 & 1 \\ 1 & 1 & 4 \end{pmatrix} \begin{pmatrix} u \\ v \\ w \end{pmatrix} = \begin{pmatrix} u - 3v + w \\ 3u + w \\ u + v + 4w \end{pmatrix}.$$

Hence $\vec{g}(u, v, w) = (u - 3v + w, 3u + w, u + v + 4w)$. Why $\vec{g}(\Omega) = D$? To answer to this question we can use the linearity of \vec{g} . Indeed, an element $(u, v, w) \in \mathbb{R}^3$ is in $\Omega = [0, 1] \times [0, 1] \times [0, 1]$ if and only if

$u, v, w \in [0, 1]$. But

$$\begin{aligned}\vec{g}(u, v, w) &= u\vec{g}(1, 0, 0) + v\vec{g}(0, 1, 0) + w\vec{g}(0, 0, 1) = \\ &= u\vec{OA} + v\vec{OB} + w\vec{OD} \in D,\end{aligned}$$

since $u, v, w \in [0, 1]$ (look at the parallelogram rule of adding vectors!). Thus, $\vec{g}(\Omega) \subset D$. Since any vector \vec{OM} , with $M \in D$ can be written as a linear combination of the form:

$$\vec{OM} = u\vec{OA} + v\vec{OB} + w\vec{OD},$$

for $u, v, w \in [0, 1]$, one has that \vec{g} is also surjective. The determinant of $M_{\vec{g}}$ is equal to $35 \neq 0$, so that \vec{g} is an isomorphism. Since $x = x(u, v, w) = u - 3v + w$, $y = y(u, v, w) = 3u + w$ and $z = z(u, v, w) = u + v + 4w$, \vec{g} is also of class C^1 . Its inverse is also a linear transformation, so that it is of class C^1 too. The Jacobian of \vec{g} is $\det M_{\vec{g}} = 35$. Now we can apply change of variables formula 4.8 and find:

$$\begin{aligned}\text{mass}(D) &= \iiint_D (x + y + z) dx dy dz = \\ &= 35 \iiint_{[0,1] \times [0,1] \times [0,1]} (u - 3v + w + 3u + w + u + v + 4w) du dv dw = \\ &= \int_0^1 \left(\int_0^1 \left(\int_0^1 (5u - 2v + 6w) du \right) dv \right) dw = \\ &= \int_0^1 \left(\int_0^1 \left(\frac{5}{2}u^2 - 2uv + 6uw \Big|_0^1 \right) dv \right) dw = \\ &= \int_0^1 \left(\int_0^1 \left(\frac{5}{2} - 2v + 6w \right) dv \right) dw = \\ &= \int_0^1 \left(\frac{5}{2}v - v^2 + 6wv \Big|_0^1 \right) dw = \int_0^1 \left(\frac{3}{2} + 6w \right) dw = \\ &= \frac{3}{2}w + 3w^2 \Big|_0^1 = \frac{3}{2} + 3 = \frac{9}{2}.\end{aligned}$$

EXAMPLE 91. (spherical coordinates) Let us recall a very important type of change of variables, namely the change of the Cartesian coordinates x, y, z into the "spherical coordinates", ρ, φ, θ (see Fig.11). Here ρ is the distance of a point $M(x, y, z)$ up to the origin O , φ is the angle between the Ox -axis and the projection \vec{OM}' of the position vector \vec{OM} ,

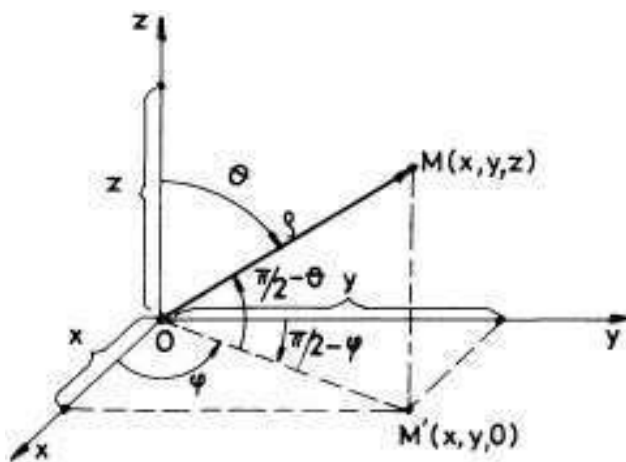

FIGURE 11

on the xOy -plane and, θ is the angle between the Oz -axis and the position vector \overrightarrow{OM} (see Fig.11). Since $\|\overrightarrow{OM'}\| = \|\overrightarrow{OM}\| \cos(\frac{\pi}{2} - \theta) = \|\overrightarrow{OM}\| \sin \theta$ and since $x = \|\overrightarrow{OM'}\| \cos \varphi$ and $y = \|\overrightarrow{OM'}\| \sin \varphi$, one has the following connections between the Cartesian coordinates (x, y, z) and the spherical coordinates (ρ, φ, θ) :

$$(4.10) \quad \begin{cases} x = x(\rho, \varphi, \theta) = \rho \sin \theta \cos \varphi, \\ y = y(\rho, \varphi, \theta) = \rho \sin \theta \sin \varphi \quad . \\ z = z(\rho, \varphi, \theta) = \rho \cos \theta \end{cases}$$

Since the Jacobian $J_{\vec{g}}(\rho, \varphi, \theta)$ of this transformation must not be zero, i.e.

$$\begin{aligned} J_{\vec{g}}(\rho, \varphi, \theta) &= \det \begin{pmatrix} \sin \theta \cos \varphi & -\rho \sin \theta \sin \varphi & \rho \cos \theta \cos \varphi \\ \sin \theta \sin \varphi & \rho \sin \theta \cos \varphi & \rho \cos \theta \sin \varphi \\ \cos \theta & 0 & -\rho \sin \theta \end{pmatrix} = \\ &= -\rho^2 \sin \theta \neq 0, \end{aligned}$$

the maximal definition domain of this regular transformation is: $\rho \in (0, \infty)$, $\varphi \in [0, 2\pi)$ and $\theta \in (0, \pi)$. We see that the maximal definition domain of \vec{g} is the infinite parallelepiped $\Omega = [0, \infty) \times [0, 2\pi] \times [0, \pi]$ without some of its exterior sides. The image of \vec{g} is the whole space \mathbb{R}^3 without the Oz -axis. During the triple integration process all of these "gaps" of dimension 1 or 2 have zero volume, so that they means "nothing" (see also remark 32). For instance, if we have to compute

the integral $I = \iiint_D f(x, y, z) dx dy dz$, where $D : x^2 + y^2 + z^2 \leq R^2$ is the closed ball of radius $R > 0$ and with centre at O , we need in general to use the change of variables formula by using spherical coordinates. Let $D^* = D \setminus \{Oz\text{-axis}\}$, let $\Omega_R = [0, R] \times [0, 2\pi] \times [0, \pi]$ and let $\Omega_R^* = (0, R) \times [0, 2\pi) \times (0, \pi)$. Then, using the remark 33, we get

$$(4.11) \quad \iiint_D f(x, y, z) dx dy dz = \iiint_{D^*} f(x, y, z) dx dy dz =$$

$$(4.12) \quad = \iiint_{\Omega_R^*} f(\rho \sin \theta \cos \varphi, \rho \sin \theta \sin \varphi, \rho \cos \theta) \cdot \rho^2 \sin \theta d\rho d\varphi d\theta$$

$$(4.13) \quad = \iiint_{\Omega_R} f(\rho \sin \theta \cos \varphi, \rho \sin \theta \sin \varphi, \rho \cos \theta) \cdot \rho^2 \sin \theta d\rho d\varphi d\theta.$$

Hence,

$$(4.14) \quad \begin{aligned} & \iiint_D f(x, y, z) dx dy dz = \\ & = \iiint_{\Omega_R} f(\rho \sin \theta \cos \varphi, \rho \sin \theta \sin \varphi, \rho \cos \theta) \cdot \rho^2 \sin \theta d\rho d\varphi d\theta, \end{aligned}$$

or

$$(4.15) \quad \begin{aligned} & \iint_{D: x^2+y^2+z^2 \leq R^2} \int f(x, y, z) dx dy dz = \\ & = \int_0^R \rho^2 \left[\int_0^{2\pi} \left(\int_0^\pi f(\rho \sin \theta \cos \varphi, \rho \sin \theta \sin \varphi, \rho \cos \theta) \sin \theta d\theta \right) d\varphi \right] d\rho. \end{aligned}$$

Let us apply now formula (4.15) in order to compute the mass of the ball $D : x^2 + y^2 + z^2 \leq 9$ with the density function $f(x, y, z) = 4|z|$:

$$\begin{aligned} \text{mass}(D) &= 4 \iint_{D: x^2+y^2+z^2 \leq 9} \int |z| dx dy dz = \\ &= 4 \int_0^3 \rho^2 \left[\int_0^{2\pi} \left(\int_0^\pi \rho |\cos \theta| \sin \theta d\theta \right) d\varphi \right] d\rho = \end{aligned}$$

$$\begin{aligned}
&= 4 \int_0^3 \rho^3 \left[\int_0^{2\pi} d\varphi \right] \left(\int_0^\pi |\cos \theta| \sin \theta d\theta \right) d\rho = \\
&= 4 \cdot 2\pi \left(\int_0^3 \rho^3 d\rho \right) \left(\int_0^\pi |\cos \theta| \sin \theta d\theta \right) = \\
&= 8\pi \frac{\rho^4}{4} \Big|_0^3 \left(\int_0^{\frac{\pi}{2}} \cos \theta \sin \theta d\theta - \int_{\frac{\pi}{2}}^\pi \cos \theta \sin \theta d\theta \right) = \\
&= 162\pi \left(\int_0^{\frac{\pi}{2}} \sin \theta d(\sin \theta) - \int_{\frac{\pi}{2}}^\pi \sin \theta d(\sin \theta) \right) = \\
&= 162\pi \left(\frac{\sin^2 \theta}{2} \Big|_0^{\frac{\pi}{2}} - \frac{\sin^2 \theta}{2} \Big|_{\frac{\pi}{2}}^\pi \right) = 162\pi.
\end{aligned}$$

Not always the too much processed formula (4.15) is useful. For instance, let $C(0, 0, a)$ be a point on the Oz -axis, $a > 0$ and let D be the closed ball with centre at a and with radius a (see Fig.12).

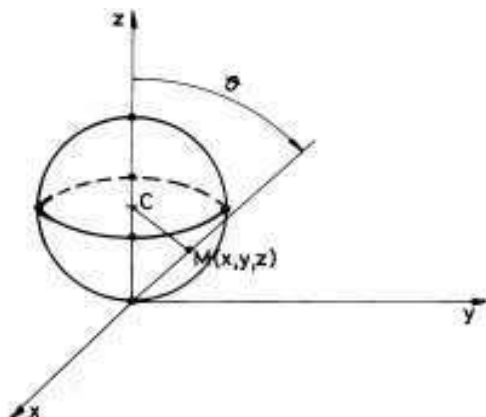

FIGURE 12

Let us compute the inertia moment $I_z = \iiint_D (x^2 + y^2) dx dy dz$ of

the solid $(D, 1)$ (or of D with the density function understood to be $f(x, y, z) = 1$). Since the sphere ∂D contains the origin O , it is a good idea to use the change of variables formula, by changing the old Cartesian coordinates (x, y, z) with the spherical coordinates (ρ, φ, θ) . It is clear that if $M(x, y, z) \in D$, then the corresponding φ and θ verify the obvious conditions: $\varphi \in [0, 2\pi]$ and $\theta \in [0, \frac{\pi}{2}]$ (see Fig.12). The Cartesian relation which describes D is: $x^2 + y^2 + (z - a)^2 \leq a^2$, or

$x^2 + y^2 + z^2 - 2az \leq 0$. If instead x, y, z we put their corresponding expressions as functions of ρ, φ, θ from (4.10), we get: $0 \leq \rho \leq 2a \cos \theta$, i.e. $\rho \in [0, 2a \cos \theta]$. Thus, the general formula (4.8) becomes:

$$\begin{aligned}
 \iiint_D (x^2 + y^2) dx dy dz &= \int_0^{2\pi} \left[\int_0^{\frac{\pi}{2}} \left(\int_0^{2a \cos \theta} \rho^2 \sin^2 \theta \cdot \rho^2 \sin \theta d\rho \right) d\theta \right] d\varphi = \\
 &= \int_0^{2\pi} \left[\int_0^{\frac{\pi}{2}} \sin^3 \theta \left(\int_0^{2a \cos \theta} \rho^4 d\rho \right) d\theta \right] d\varphi = \\
 &= \left(\int_0^{2\pi} d\varphi \right) \left[\int_0^{\frac{\pi}{2}} \sin^3 \theta \left(\int_0^{2a \cos \theta} \rho^4 d\rho \right) d\theta \right] = \\
 &= 2\pi \left[\int_0^{\frac{\pi}{2}} \sin^3 \theta \left(\int_0^{2a \cos \theta} \rho^4 d\rho \right) d\theta \right] = \\
 (4.16) \quad &= 2\pi \left[\int_0^{\frac{\pi}{2}} \sin^3 \theta \left(\frac{\rho^5}{5} \Big|_0^{2a \cos \theta} \right) d\theta \right] = \frac{2^6 a^5 \pi}{5} \int_0^{\frac{\pi}{2}} \sin^3 \theta \cos^5 \theta d\theta.
 \end{aligned}$$

Now we have a good opportunity to use formula 7) of theorem 63: $B(x, y) = 2 \int_0^{\frac{\pi}{2}} \sin^{2x-1} u \cos^{2y-1} u du$ (the trigonometric expression of the Euler's beta function), in order to compute the last integral in 4.16.

$$\int_0^{\frac{\pi}{2}} \sin^3 \theta \cos^5 \theta d\theta = \frac{1}{2} B(2, 3) = \frac{1}{2} \frac{\Gamma(2)\Gamma(3)}{\Gamma(5)} = \frac{1}{2} \frac{1 \cdot 2}{4!} = \frac{1}{24}.$$

Hence,

$$\iiint_D (x^2 + y^2) dx dy dz = \frac{2^6 a^5 \pi}{5} \cdot \frac{1}{24} = \frac{8\pi a^5}{15}.$$

EXAMPLE 92. (*cylindrical coordinates*) Let us come back to Fig.11 and associate to any point $M(x, y, z)$ the number $r = \left\| \overrightarrow{OM'} \right\| \in [0, \infty)$, the distance of M' (the projection of M on the xOy -plane) up to the origin O , the angle $\varphi \in [0, 2\pi]$ and the height $z \in \mathbb{R}$ of M . The association $(x, y, z) \rightsquigarrow (r, \varphi, z)$ gives rise to a new change of variables. Here (r, φ, z) are called *cylindrical coordinates* of M and the corresponding change of variables is described by the following functions:

$$(4.17) \quad \begin{cases} x = x(r, \varphi, z) = r \cos \varphi \\ y = y(r, \varphi, z) = r \sin \varphi \\ z = z(r, \varphi, z) = z \end{cases},$$

where $r \in (0, \infty)$, $\varphi \in [0, 2\pi)$ and $z \in \mathbb{R}$. The slight modification in the definition domain of the vector function $\vec{g}(r, \varphi, z) = (r \cos \varphi, r \sin \varphi, z)$ appeared because we want this function to be a smooth deformation (here the Jacobian is equal to r , which must be not zero). As in the case of spherical coordinates, what we got out ($r = 0$, i.e. the Oz -axis, $\varphi = 2\pi$, i.e. the zOx -plane) are 1 or 2-dimension pieces, so not important during the triple integration process. The name "cylindrical coordinates" comes from the fact that the parallelepiped $\Omega = [0, R] \times [0, 2\pi] \times [0, h]$ is deformed through the above cylindrical deformation \vec{g} into the cylindrical domain $D : x^2 + y^2 \leq R^2, 0 \leq z \leq h$. This last one is not "in fact" a smooth deformation, but the exception points are neglected during a process of triple integration, because a set of such points has always zero volume. This is why we usually force things and do not care of the true definition of a deformation!

Let us compute for instance the coordinates of the mass centre of the cylindrical solid (D, f) , where $D : y^2 + z^2 \leq 16, 3 \leq x \leq 5$ and $f(x, y, z) = 2x + 1$. Since the domain is symmetric (like a geometrical object!) w.r.t. Ox -axis and since the distribution of masses is also symmetric w.r.t. to the same line Ox , the coordinates of the mass centre G of the solid are $(x_G, 0, 0)$. Hence, we compute only (see formula (2.4)) two triple integrals.

$$x_G = \frac{\iiint_D x f(x, y, z) dx dy dz}{\iiint_D f(x, y, z) dx dy dz}.$$

Since the matter is about a cylindrical domain, we apply the change of variable formula (4.8), but not with exactly the functions which appear in formula (4.17). We have to make some small modifications in this formula, but not in the essential feature of it. In the initial description of the cylindrical coordinates, the Oz -axis was a "pivot". In our case "the pivot" is the Ox -axis, so that the cylindrical coordinates in our case are (r, φ, x) for any point $M(x, y, z)$ (Why?-make a draw and explain which are r and φ in this last situation!). Thus, the appropriate formulas are:

$$\begin{cases} x = x \\ y = r \cos \varphi \\ z = r \sin \varphi \end{cases},$$

where $r \in [0, 4]$, $\varphi \in [0, 2\pi]$ and $x \in [3, 5]$. Now we are really ready to use the change of variables formula (4.8) with the Jacobian equal to r .

$$\begin{aligned} \text{mass}(D) &= \iiint_D (2x + 1) dx dy dz = 2 \iiint_D x dx dy dz + \iiint_D dx dy dz = \\ &= 2 \iiint_D x dx dy dz + \text{vol}(D) = 32\pi + 2 \iiint_D x dx dy dz = \\ &= 32\pi + \int_0^4 r \left(\int_0^{2\pi} \left[\int_3^5 2x dx \right] d\varphi \right) dr = \\ &= 32\pi + \int_0^4 r \left(\int_0^{2\pi} \left[x^2 \Big|_3^5 \right] d\varphi \right) dr = 32\pi + 16 \int_0^4 r \left(\int_0^{2\pi} d\varphi \right) dr = \\ &= 32\pi + 32\pi \cdot 8 = 288\pi. \end{aligned}$$

Let us compute now $\iiint_D x f(x, y, z) dx dy dz$, i.e. the static moment w.r.t. yOz -plane.

$$\iiint_D x(2x + 1) dx dy dz = 2 \iiint_D x^2 dx dy dz + \iiint_D x dx dy dz.$$

But the last triple integral on the right was just computed above, so that:

$$\begin{aligned} \iiint_D x(2x + 1) dx dy dz &= 128\pi + 2 \int_0^4 r \left(\int_0^{2\pi} \left[\int_3^5 x^2 dx \right] d\varphi \right) dr = \\ &= 128\pi + \frac{2}{3} \int_0^4 r \left(\int_0^{2\pi} \left[5^3 - 3^3 \right] d\varphi \right) dr = 128\pi + \frac{3136}{3}\pi = \frac{3520\pi}{3}. \end{aligned}$$

Finally, $x_G = \frac{3520\pi}{3 \cdot 288\pi} \approx 4.074 \in [3, 5]$.

The next result is very important in Mechanics. It can be done for simple, double, triple or surface integrals (these last ones will be studied in the next chapter). We shall give it here only for triple integrals. We leave as an exercise for the reader to state and to prove such a result for simple, double or surface integrals.

THEOREM 92. (*the reduction theorem in Statics*) *Let*

$$(D_1, f_1), (D_2, f_2), \dots, (D_n, f_n)$$

be n general nonoverlapping solids in \mathbb{R}^3 and let

$$G_1(x_1, y_1, z_1), G_2(x_2, y_2, z_2), \dots, G_n(x_n, y_n, z_n)$$

be their corresponding mass centres. Then the mass centre $G(x_G, y_G, z_G)$ of the system of solids (D, f) , where

$$D = D_1 \cup D_2 \cup \dots \cup D_n$$

and $f(x, y, z) = f_k(x, y, z)$ if $(x, y, z) \in D_k$, has the coordinates x_G, y_G and z_G computed with the formulas:

$$(4.18) \quad \begin{aligned} x_G &= \frac{x_1 \text{mass}(D_1) + x_2 \text{mass}(D_2) + \dots + x_n \text{mass}(D_n)}{\text{mass}(D)}, \\ y_G &= \frac{y_1 \text{mass}(D_1) + y_2 \text{mass}(D_2) + \dots + y_n \text{mass}(D_n)}{\text{mass}(D)}, \\ z_G &= \frac{z_1 \text{mass}(D_1) + z_2 \text{mass}(D_2) + \dots + z_n \text{mass}(D_n)}{\text{mass}(D)}, \end{aligned}$$

where obviously $\text{mass}(D) = \text{mass}(D_1) + \text{mass}(D_2) + \dots + \text{mass}(D_n)$. The above fractions, say the first one, is called the weighted average of the numbers x_1, x_2, \dots, x_n , with the weights $\text{mass}(D_1), \dots, \text{mass}(D_n)$ respectively.

PROOF. To prove this theorem, we simply use the main properties of the triple integrals, described in theorem 87 and the definition of the mass centre of a solid (see formulas (2.4)). We also prove the formula for x_G only, because the other two can be proved in exactly the same manner. Thus,

$$\begin{aligned} x_G &= \frac{\iiint_D x f(x, y, z) dx dy dz}{\text{mass}(D)} = \\ &= \frac{\iiint_{D_1} x f(x, y, z) dx dy dz + \dots + \iiint_{D_n} x f(x, y, z) dx dy dz}{\text{mass}(D)} = \\ &= \frac{\frac{\iiint_{D_1} x f_1(x, y, z) dx dy dz}{\text{mass}(D_1)} \cdot \text{mass}(D_1) + \dots + \frac{\iiint_{D_n} x f_n(x, y, z) dx dy dz}{\text{mass}(D_n)} \cdot \text{mass}(D_n)}{\text{mass}(D)} = \\ &= \frac{x_1 \text{mass}(D_1) + x_2 \text{mass}(D_2) + \dots + x_n \text{mass}(D_n)}{\text{mass}(D)}. \end{aligned}$$

□

EXAMPLE 93. (a system of two solids) Let us apply this basic result (theorem 92) to compute the coordinates x_G , y_G and z_G , the coordinates of the mass centre for the system D , formed with two homogenous solids D_1 , D_2 (considered with the density function $f = 1$), where D_1 is the "north" hemisphere of the ellipsoid: $\frac{x^2}{a^2} + \frac{y^2}{b^2} + \frac{z^2}{c^2} \leq 1$, $z \geq 0$ and D_2 is the "south" hemisphere of the ball: $x^2 + (y-2b)^2 + z^2 \leq b^2$, $z \leq 0$, where $a, b, c > 0$. To compute the coordinates of the mass centres for D_1 and D_2 respectively, we need appropriate changes of variables, inspired of the usage of the spherical coordinates. For D_1 we consider the "general spherical coordinates", ρ, φ, θ :

$$D_1 : \begin{cases} x = x(\rho, \varphi, \theta) = \rho a \sin \theta \cos \varphi, \\ y = y(\rho, \varphi, \theta) = \rho b \sin \theta \sin \varphi, \\ z = z(\rho, \varphi, \theta) = \rho c \cos \theta. \end{cases},$$

where $\rho \in [0, 1]$, $\varphi \in [0, 2\pi]$ and $\theta \in [0, \frac{\pi}{2}]$. The Jacobian of this transformation is equal to $-abc\rho^2 \sin \theta$ (prove this!). For instance, let us compute the volume of D_1 (which is equal to its mass because the density function is 1) by using formula 4.8:

$$\begin{aligned} \text{vol}(D_1) &= \iiint_{D_1} dx dy dz = abc \int_0^1 \rho^2 \left[\int_0^{2\pi} \left(\int_0^{\frac{\pi}{2}} \sin \theta d\theta \right) d\varphi \right] d\rho = \\ &= abc \left(\int_0^1 \rho^2 d\rho \right) \left(\int_0^{2\pi} d\varphi \right) \left(\int_0^{\frac{\pi}{2}} \sin \theta d\theta \right) = abc \cdot \frac{1}{3} \cdot 2\pi \cdot 1 = \frac{2\pi abc}{3}. \end{aligned}$$

Thus, the volume of the entire ellipsoid $\frac{x^2}{a^2} + \frac{y^2}{b^2} + \frac{z^2}{c^2} \leq 1$ is equal to $\frac{4\pi abc}{3}$. If $a = b = c = R$, we get the volume of a sphere of radius R : $\frac{4\pi R^3}{3}$. We shall need below the volume of a half of a ball of radius b : $\text{vol} = \frac{2\pi b^3}{3}$.

$$\text{Let us compute } z_1 = \frac{\iiint_{D_1} z dx dy dz}{\iiint_{D_1} dx dy dz}, \text{ the } z\text{-coordinate of } G_1, \text{ the mass}$$

centre of D_1 . Since Oz is a symmetry axis for D_1 , $y_1 = x_1 = 0$.

$$\begin{aligned} \iiint_{D_1} z dx dy dz &= abc^2 \int_0^1 \rho^3 \left[\int_0^{2\pi} \left(\int_0^{\frac{\pi}{2}} \sin \theta \cos \theta d\theta \right) d\varphi \right] d\rho = \\ &= \frac{abc^2}{4} \cdot 2\pi \cdot \frac{\sin^2 \theta}{2} \Big|_0^{\frac{\pi}{2}} = \frac{\pi abc^2}{4}. \end{aligned}$$

Hence $z_1 = \frac{\frac{\pi abc^2}{4}}{\frac{4\pi abc}{3}} = \frac{3c}{16}$.

Since D_2 is symmetric w.r.t. the line $x = 0, y = 2b, x_2 = 0, y_2 = 2b$,

so that we need only to compute $z_2 = \frac{\iiint_{D_2} z dx dy dz}{\iiint_{D_2} dx dy dz}$. Here G_2 , the mass

centre of D_2 has the coordinates x_2, y_2 and z_2 . An appropriate change of variables for D_2 are:

$$\begin{cases} x = x(\rho, \varphi, \theta) = \rho \sin \theta \cos \varphi, \\ y = y(\rho, \varphi, \theta) = 2b + \rho \sin \theta \sin \varphi, \\ z = z(\rho, \varphi, \theta) = \rho \cos \theta. \end{cases}$$

where $\rho \in [0, b]$, $\varphi \in [0, 2\pi]$ and $\theta \in [\frac{\pi}{2}, \pi]$. The Jacobian is obviously $J = -\rho^2 \sin \theta$, because the function y was modified by the addition of a constant. Hence,

$$\begin{aligned} \iiint_{D_2} z dx dy dz &= \int_0^b \rho^3 \left[\int_0^{2\pi} \left(\int_{\frac{\pi}{2}}^{\pi} \sin \theta \cos \theta d\theta \right) d\varphi \right] d\rho = \\ &= \left(\int_{\frac{\pi}{2}}^{\pi} \sin \theta \cos \theta d\theta \right) \cdot 2\pi \cdot \frac{b^4}{4} = -\frac{\pi b^4}{4}. \end{aligned}$$

Thus $z_2 = \frac{-\frac{\pi b^4}{4}}{\frac{2\pi b^3}{3}} = -\frac{3b}{8}$.

Let us use now formula (4.18) to compute x_G, y_G and z_G .

$$\begin{aligned} x_G &= \frac{0 \cdot \text{vol}(D_1) + 0 \cdot \text{vol}(D_2)}{\text{vol}(D)} = 0 \\ y_G &= \frac{0 \cdot \text{vol}(D_1) + 2b \cdot \text{vol}(D_2)}{\text{vol}(D)} = \frac{2b \cdot \frac{2\pi b^3}{3}}{\frac{2\pi abc}{3} + \frac{2\pi b^3}{3}} = \frac{2b^3}{ac + b^2} \\ z_G &= \frac{\frac{3c}{16} \cdot \text{vol}(D_1) - \frac{3b}{8} \cdot \text{vol}(D_2)}{\text{vol}(D)} = \frac{\frac{3c}{16} \cdot \frac{2\pi abc}{3} - \frac{3b}{8} \cdot \frac{2\pi b^3}{3}}{\frac{2\pi abc}{3} + \frac{2\pi b^3}{3}} = \frac{3}{16} \frac{ac^2 - b^3}{ac + b^2}. \end{aligned}$$

Many other practical properties of the mass centres can be proved by simple applications of the basic properties of triple integrals. For instance, for two nonoverlapping solids $(D_1, f_1), (D_2, f_2)$ with their mass centres $G_1(x_1, y_1, z_1)$ and $G_2(x_2, y_2, z_2)$, the mass centre G of the system (D, f) , where $D = D_1 \cup D_2$, is on the segment which joins G_1 and G_2 (prove it!). What happens when $G_1 = G_2$?

5. Problems and exercises

1. Find the mass of the following solids with their corresponding density function $f(x, y, z)$.

a) $D = [0, 1] \times [0, 1] \times [0, 1]$, $f(x, y, z) = xy \sin(\pi z)$; b) $D = [0, 1] \times [0, 2] \times [-2, 3]$, $f(x, y, z) = 3z$;

c) $x^2 + y^2 \leq 1$, $1 \leq z \leq 2$, $f(x, y, z) = \sqrt{x^2 + y^2}$; d) $x^2 + y^2 + z^2 \leq 1$, $f(x, y, z) = \sqrt{1 + (x^2 + y^2 + z^2)^{3/2}}$;

e) $x^2 + y^2 \leq 2x$, $y \geq 0$, $z \geq 0$, $z \leq a$, where $a > 0$, $f(x, y, z) = z\sqrt{x^2 + y^2}$; f) the domain bounded by $x^2 + y^2 = R^2$, $z = 0$, $z = 1$, $y \leq x\sqrt{3}$, $x, y, z \geq 0$, $f(x, y, z) = 1$; g) the tetrahedron bounded by $x = 0$, $y = 0$, $z = 0$, $x + y + z = 1$, $f(x, y, z) = (1 + x + y + z)^{-3}$.

2. Find the volumes of the following domains:

a) the domain D bounded by $y^2 + \frac{z^2}{4} = 2x$, $x = 1$; b) $x^2 + y^2 + z^2 - 4z \leq 0$; c) $\frac{(x-1)^2}{a^2} + \frac{y^2}{a^2} + \frac{(z+4)^2}{b^2} \leq 1$;

d) $\frac{x^2 + y^2}{a} \leq z \leq a$, $a > 0$, $0 \leq y \leq x$; e) $x^2 + y^2 + z^2 \leq z$; f) $1 \leq x \leq 2$, $1 \leq y \leq x$, $1 \leq z \leq xy$.

3. Find the coordinates of the mass centre for the following solids:

a) $x^2 + y^2 + z^2 \leq 1$, $f(x, y, z) = \sqrt{x^2 + y^2 + z^2}$; b) $x^2 + y^2 \leq z^2$, $0 \leq z \leq 1$; $f(x, y, z) = \sqrt{x^2 + y^2}$;

c) $x^2 + y^2 \leq 1$, $1 \leq z \leq 2$, $f(x, y, z) = 2z$;

4. Find the coordinates of the mass centre of the following domains, bounded by:

a) $x^2 + y^2 = z$, $0 \leq z \leq 1$; b) $x^2 + y^2 = z$, $x + y + z = 0$; c) $y^2 + 2z^2 = 4x$, $x = 2$;

5. Find the inertia moment of the following solids w.r.t. Ox -axis:

a) $x^2 + y^2 + z^2 \leq 9$, $f = 1$; b) $(x-1)^2 + y^2 + z^2 \leq 1$; c) $x^2 + y^2 \leq 2x$, $x \geq 0$, $y \geq 0$, $0 \leq z \leq 2$, $f = 2z$;

d) $[0, 1] \times [0, 2] \times [0, 3]$; e) $x^2 + z^2 \leq y^2$, $0 \leq y \leq 2$, $f = 2y + 1$; f) the general parallelepiped generated by \overrightarrow{OA} , \overrightarrow{OB} , \overrightarrow{OC} , where $A(1, 3, 1)$, $B(-2, 1, 1)$ and $C(0, -1, 2)$; g) the tetrahedron $[OABV]$, where $A(-1, 3, 2)$, $B(-3, 1, 4)$ and $V(1, 1, 1)$.

6. Find the mass centre for $D = D_1 \cup D_2 \cup D_3$, where $D_1 : x^2 + y^2 \leq 9$, $0 \leq z \leq 3$, $f_1(x, y, z) = z$,

$D_2 : (x-5)^2 + y^2 + z^2 \leq 4$, $f_2(x, y, z) = x$ and $D_3 : [10, 11] \times [5, 6] \times [0, 1]$, $f_3(x, y, z) = z$.

CHAPTER 8

Surface integrals

1. Deformation of a 2D-domain into a space surface

Let uov be a plane Cartesian coordinate system in \mathbb{R}^2 and let $Oxyz$ be a Cartesian coordinate system in \mathbb{R}^3 . Let D be a plane general domain (bounded, closed, connected and ∂D is a piecewise smooth curve) and let $\vec{g} : D \rightarrow \mathbb{R}^3$ be a continuous injective and piecewise of class C^1 field. Moreover, we assume that at "almost" every point M of $S = \vec{g}(D)$ there exists a unique tangent plane to S . "Almost" means that the set A of points on S at which we have not a unique tangent plane has zero area (or $area(g^{-1}(A)) = 0$). We always assume that S is closed as a topological object in \mathbb{R}^3 , i.e. that $\mathbb{R}^3 \setminus S$ is an open subset of \mathbb{R}^3 . We recall that a subset A of \mathbb{R}^3 is said to be open (in \mathbb{R}^3) if for any point P of it there exists an open ball $B(P, r)$, $r > 0$ of \mathbb{R}^3 with $B(P, r) \subset A$. Such a field \vec{g} as above is said to be a (piecewise smooth) *deformation* of D into the (*space*) *surface* $S = \vec{g}(D)$. Since $\vec{g}(u, v) = (x(u, v), y(u, v), z(u, v))$, where $x(u, v)$, $y(u, v)$ and $z(u, v)$ are piecewise functions of class C^1 of independent variables u and v , we also represent \vec{g} or S in a parametric way:

$$(1.1) \quad \vec{g} : \begin{cases} x = x(u, v) \\ y = y(u, v) \\ z = z(u, v) \end{cases}, (u, v) \in D .$$

Here x of $x(u, v)$ is the name of a function of two variables u and v . For instance, $x(u, v) = u^2 - v^2$, etc. By an abusive language we shall use (x, y, z) either as free (independent) variables in \mathbb{R}^3 , or as names of the three functions of u and v like in formula (1.1). The three equalities in formula (1.1) are called *the parametric equations of the surface* $S = \vec{g}(D)$ and the surface itself S is also called the support of the deformation \vec{g} . Such a deformation \vec{g} is also called a *parametric sheet*. The same surface S can have many parametric representations. For instance, the plane $2x - 3y + z - 1 = 0$ can have the following three

parametric representations:

$$\vec{g}_1 : \begin{cases} x = x \\ y = y \\ z = -2x + 3y + 1 \end{cases} \quad (x, y) \in \mathbb{R}^2.$$

Here $D = \mathbb{R}^2$, $u = x$, $v = y$, $x(u, v) = u$, $y(u, v) = v$ and $z(u, v) = -2u + 3v + 1$. Another parametrization of the same plane is:

$$\vec{g}_2 : \begin{cases} x = x \\ y = (2x + z - 1)/3 \\ z = z \end{cases} \quad (x, z) \in \mathbb{R}^2.$$

It is now clear how do we construct the last one:

$$\vec{g}_1 : \begin{cases} x = (1 - z + 3y)/2 \\ y = y \\ z = z \end{cases} \quad (y, z) \in \mathbb{R}^2.$$

Hence, we can simply call a surface any deformation $\vec{g} : D \rightarrow \mathbb{R}^3$ or only the support $S = \vec{g}(D)$ of this last one. In practice, we give a surface by its parametric equations or by an implicit form of it, $S = \{(x, y, z) : F(x, y, z) = 0\}$, where F is of class C^1 and

$$\text{grad } F(x, y, z) = \left(\frac{\partial F}{\partial x}(x, y, z), \frac{\partial F}{\partial y}(x, y, z), \frac{\partial F}{\partial z}(x, y, z) \right) \neq \vec{0},$$

i.e. in a neighborhood of each point $M(a, b, c)$ of this surface (i.e. (a, b, c) verifies the equation $F(x, y, z) = 0$) we can apply the implicit function theorem (see [Po], theorem 82) and we can represent the surface in one of the following three forms:

$$S : \begin{cases} x = x \\ y = y \\ z = z(x, y) \end{cases}, (x, y) \in D, \quad S : \begin{cases} x = x \\ y = y(x, z) \\ z = z \end{cases}, (x, z) \in D,$$

$$S : \begin{cases} x = x(y, z) \\ y = y \\ z = z \end{cases}, (y, z) \in D.$$

For instance, the unity sphere $S = \{(x, y, z) : x^2 + y^2 + z^2 = 1\}$ is given here as an implicit equation. If we want to express it as $z = z(x, y)$ about a point $M_0(a, b, c)$, the partial differential $\frac{\partial F}{\partial z}(a, b, c)$ must be not zero, i.e. $2c \neq 0$, or $c \neq 0$. So we can do this about all points $M_0(a, b, c)$ on the sphere S , but the points on the circle $x^2 + y^2 = 1, z = 0$. Since $z = \pm\sqrt{1 - x^2 - y^2}$, round such a point $M_0(a, b, c)$ z cannot be defined as a univalent (univalued) function. About such a point we can represent the equation of the sphere S as an explicit function

w.r.t. x or y . Indeed, if $c = 0$, at least one of a or b must be not zero (otherwise $0 + 0 + 0 = 1!$), say $b > 0$. Then the continuous expression $\pm\sqrt{1 - x^2 - z^2}$ must be positive on a neighborhood U (find it!) of $(a, b, 0)$, so that $y = \sqrt{1 - x^2 - z^2}$ on U .

Let us recall now some facts from the differential geometry of a surface $S : \begin{cases} x = x(u, v) \\ y = y(u, v) \\ z = z(u, v) \end{cases}, (u, v) \in D$. Let $P_0(u_0, v_0)$ be a fixed point

in the plane domain D (see Fig.1) and let denote the above deformation $\vec{g}(u, v)$ by $\vec{r}(u, v) = x(u, v)\vec{i} + y(u, v)\vec{j} + z(u, v)\vec{k} = \vec{OM}_0$, the position vector of $M_0(x_0, y_0, z_0)$, where $x_0 = x(u_0, v_0)$, $y_0 = y(u_0, v_0)$, $z_0 = z(u_0, v_0)$. To easier understand what is M_0 , we put $\vec{r}(P_0) = M_0$, etc. (see Fig.1). Thus, a running point M on the surface S is the image through \vec{r} of a running point $P(u, v)$ of the plane domain D . This means that $M(x(u, v), y(u, v), z(u, v))$ is such a running point on S . Usually, we associate to any point $M_0(x(u_0, v_0), y(u_0, v_0), z(u_0, v_0))$ of S two important vectors which generate the tangent plane T_{M_0} at M_0 to S . These are:

$$(1.2) \quad \begin{aligned} \vec{r}_u(P_0) &= x_u(u_0, v_0)\vec{i} + y_u(u_0, v_0)\vec{j} + z_u(u_0, v_0)\vec{k} \text{ and} \\ \vec{r}_v(P_0) &= x_v(u_0, v_0)\vec{i} + y_v(u_0, v_0)\vec{j} + z_v(u_0, v_0)\vec{k}. \end{aligned}$$

Our hypotheses on S say that the tangent plane T_{M_0} exists and it is unique, so that the two vectors $\vec{r}_u(P_0)$ and $\vec{r}_v(P_0)$ which give its direction $\vec{N}(P_0) = \vec{r}_u(P_0) \times \vec{r}_v(P_0)$ cannot be collinear. The versor $\vec{n}(P_0) = \frac{\vec{r}_u(P_0) \times \vec{r}_v(P_0)}{\|\vec{r}_u(P_0) \times \vec{r}_v(P_0)\|}$ is called the normal versor at M_0 to S . Here $x_u = \frac{\partial x}{\partial u}$, $x_v = \frac{\partial x}{\partial v}$, $\vec{r}_u = \frac{\partial \vec{r}}{\partial u}$, ... etc. Thus, the equation of the tangent plane T_{M_0} is:

$$\det \begin{pmatrix} X - x_0 & Y - y_0 & Z - z_0 \\ x_u(u_0, v_0) & y_u(u_0, v_0) & z_u(u_0, v_0) \\ x_v(u_0, v_0) & y_v(u_0, v_0) & z_v(u_0, v_0) \end{pmatrix} = 0.$$

Let us introduce three new functions $A(u, v)$, $B(u, v)$ and $C(u, v)$: $\vec{r}_u(u, v) \times \vec{r}_v(u, v) = A(u, v)\vec{i} + B(u, v)\vec{j} + C(u, v)\vec{k}$. Hence the normal versor $\vec{n}(u, v)$, at a running point $M(x(u, v), y(u, v), z(u, v))$ of S , has the following expression:

$$(1.3) \quad \begin{aligned} \vec{n}(u, v) &= \frac{A(u, v)}{\sqrt{A^2(u, v) + B^2(u, v) + C^2(u, v)}}\vec{i} + \\ &+ \frac{B(u, v)}{\sqrt{A^2(u, v) + B^2(u, v) + C^2(u, v)}}\vec{j} + \end{aligned}$$

$$+ \frac{C(u, v)}{\sqrt{A^2(u, v) + B^2(u, v) + C^2(u, v)}} \vec{k}.$$

(see Fig.1).

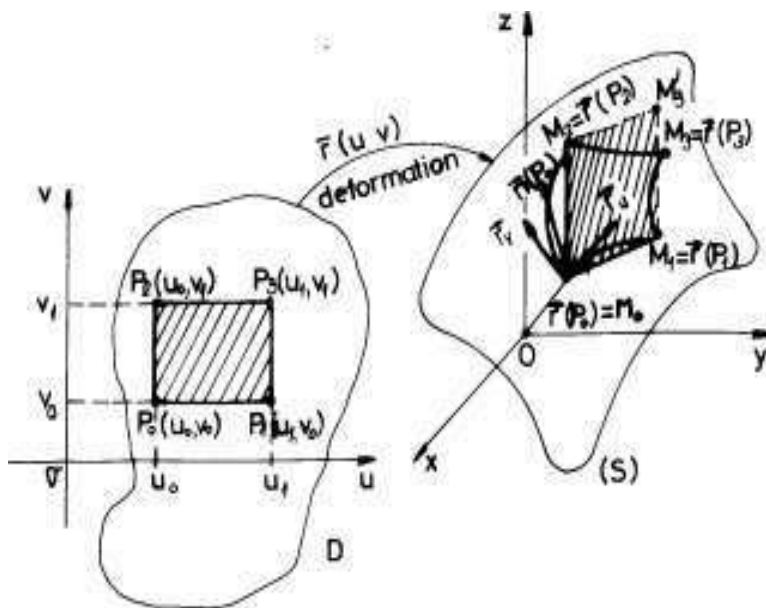

FIGURE 1

We are interested now how the area of a small rectangle $[P_0P_1P_2P_3]$, where $P_0(u_0, v_0)$, $P_1(u_1, v_0)$, $P_2(u_0, v_1)$ and $P_3(u_1, v_1)$ changes when we deform this rectangle through the deformation $\vec{r}(u, v)$ up to the surface $[M_0M_1M_2M_3]$ (see Fig.1). The idea is the same like the idea used in proving theorem 81.

THEOREM 93. *With the above notation and hypotheses, one has*

$$(1.4) \quad \begin{aligned} \text{area}[M_0M_1M_2M_3] &\approx \\ &\approx \sqrt{A^2(u_0, v_0) + B^2(u_0, v_0) + C^2(u_0, v_0)} \cdot \text{area}[P_0P_1P_2P_3], \end{aligned}$$

the approximation being better and better as the diameter of $[P_0P_1P_2P_3]$ is smaller and smaller. Hence, the number

$$\sqrt{A^2(u_0, v_0) + B^2(u_0, v_0) + C^2(u_0, v_0)}$$

acts as a dilation or contraction coefficient of the elementary area

$$\text{area}[P_0P_1P_2P_3] = (u_1 - u_0)(v_1 - v_0).$$

Formula (1.4) can also symbolically be written:

$$(1.5) \quad d\sigma = \sqrt{A^2 + B^2 + C^2} du dv,$$

where $d\sigma$ is called an element of area on the surface S . The point $P_0(u_0, v_0)$ can be substituted with any other fixed point $P(\xi, \eta)$ of the rectangle

$[P_0P_1P_2P_3]$, i.e.

$$(1.6) \quad \begin{aligned} \text{area}[M_0M_1M_2M_3] &\approx \\ &\approx \sqrt{A^2(\xi, \eta) + B^2(\xi, \eta) + C^2(\xi, \eta)} \cdot \text{area}[P_0P_1P_2P_3]. \end{aligned}$$

PROOF. Let us approximate the area of the 3D-curvilinear parallelogram

$[M_0M_1M_2M_3]$ with the area of the parallelogram $[M_0M_1M_2M'_3]$ generated by the vectors $\overrightarrow{M_0M_1}$ and $\overrightarrow{M_0M_2}$ (see Fig.1), i.e. with the number

$$(1.7) \quad \left\| \overrightarrow{M_0M_1} \times \overrightarrow{M_0M_2} \right\| = \left\| \det \begin{pmatrix} \vec{i} & \vec{j} & \vec{k} \\ x_1 - x_0 & y_1 - y_0 & z_1 - z_0 \\ x_2 - x_0 & y_2 - y_0 & z_2 - z_0 \end{pmatrix} \right\|,$$

where $x_1 = x(u_1, v_0)$, $y_1 = y(u_1, v_0)$, $z_1 = z(u_1, v_0)$, $x_2 = x(u_0, v_1)$, $y_2 = y(u_0, v_1)$, $z_2 = z(u_0, v_1)$. But

$$\begin{aligned} x_1 - x_0 &= x(u_1, v_0) - x(u_0, v_0) = \\ &\stackrel{\text{Lagrange}}{=} \frac{\partial x}{\partial u}(c_1, v_0) \cdot (u_1 - u_0) \approx \frac{\partial x}{\partial u}(u_0, v_0) \cdot (u_1 - u_0), \end{aligned}$$

because $c_1 \in (u_0, u_1)$ and $u_1 - u_0$ is small enough. Thus, in the same way, we can deduce the following approximations:

$$\begin{aligned} x_1 - x_0 &\approx \frac{\partial x}{\partial u}(u_0, v_0) \cdot (u_1 - u_0) \approx \frac{\partial x}{\partial u}(\xi, \eta) \cdot (u_1 - u_0) \\ y_1 - y_0 &\approx \frac{\partial y}{\partial u}(u_0, v_0) \cdot (u_1 - u_0) \approx \frac{\partial y}{\partial u}(\xi, \eta) \cdot (u_1 - u_0) \\ z_1 - z_0 &\approx \frac{\partial z}{\partial u}(u_0, v_0) \cdot (u_1 - u_0) \approx \frac{\partial z}{\partial u}(\xi, \eta) \cdot (u_1 - u_0) \\ x_2 - x_0 &\approx \frac{\partial x}{\partial v}(u_0, v_0) \cdot (v_1 - v_0) \approx \frac{\partial x}{\partial v}(\xi, \eta) \cdot (v_1 - v_0) \\ y_2 - y_0 &\approx \frac{\partial y}{\partial v}(u_0, v_0) \cdot (v_1 - v_0) \approx \frac{\partial y}{\partial v}(\xi, \eta) \cdot (v_1 - v_0) \\ z_2 - z_0 &\approx \frac{\partial z}{\partial v}(u_0, v_0) \cdot (v_1 - v_0) \approx \frac{\partial z}{\partial v}(\xi, \eta) \cdot (v_1 - v_0). \end{aligned}$$

Let us come back to formula (1.7) and obtain:

$$\left\| \overrightarrow{M_0M_1} \times \overrightarrow{M_0M_2} \right\| \approx$$

$$\begin{aligned} &\approx \left\| \det \begin{pmatrix} \vec{i} & \vec{j} & \vec{k} \\ \frac{\partial x}{\partial u} & \frac{\partial y}{\partial u} & \frac{\partial z}{\partial u} \\ \frac{\partial x}{\partial v} & \frac{\partial y}{\partial v} & \frac{\partial z}{\partial v} \end{pmatrix} \right\|_{(u_0, v_0)} (u_1 - u_0)(v_1 - v_0) = \\ &\sqrt{A^2(u_0, v_0) + B^2(u_0, v_0) + C^2(u_0, v_0)}(u_1 - u_0)(v_1 - v_0) \approx \\ &\approx \sqrt{A^2(\xi, \eta) + B^2(\xi, \eta) + C^2(\xi, \eta)}(u_1 - u_0)(v_1 - v_0), \end{aligned}$$

or

$$\begin{aligned} &\text{area}[M_0M_1M_2M_3] \approx \\ &\approx \sqrt{A^2(u_0, v_0) + B^2(u_0, v_0) + C^2(u_0, v_0)} \cdot \text{area}[P_0P_1P_2P_3] \approx \\ &\sqrt{A^2(\xi, \eta) + B^2(\xi, \eta) + C^2(\xi, \eta)} \cdot \text{area}[P_0P_1P_2P_3]. \end{aligned}$$

□

Let us compute the element of area $d\sigma$ on different surfaces S with the help of formula (1.5).

EXAMPLE 94. (*cylindrical deformation*) Let $D = [0, 2\pi] \times [0, h]$ (see Fig.2) and let $\vec{r}(u, v) = R \cos u \vec{i} + R \sin u \vec{j} + v \vec{k}$, $u \in [0, 2\pi]$, $v \in [0, h]$ be a deformation defined on D . Since the image $\vec{r}(D)$ is the circular cylinder of radius R and height h (see Fig.2),

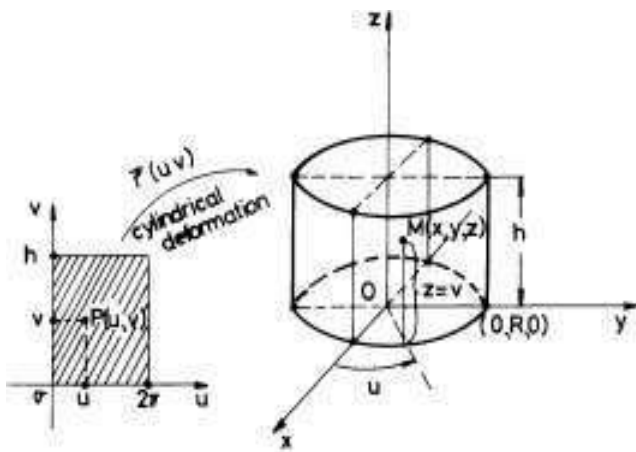

FIGURE 2

this last deformation is said to be a cylindrical deformation. The parametric equations of this cylinder are:

$$(1.8) \quad \vec{g} : \begin{cases} x = x(u, v) = R \cos u \\ y = y(u, v) = R \sin u \\ z = z(u, v) = v \end{cases}, (u, v) \in D = [0, 2\pi] \times [0, h].$$

Let us compute the element of area $d\sigma$ on this cylinder. We need only to compute A , B , and C as the coordinates functions of $\vec{r}_u(u, v) \times \vec{r}_v(u, v)$. But

$$\begin{aligned} \vec{r}_u &= -R \sin u \vec{i} + R \cos u \vec{j} + 0 \cdot \vec{k} \\ \vec{r}_v &= 0 \cdot \vec{i} + 0 \cdot \vec{j} + \vec{k}. \end{aligned}$$

Thus,

$$\vec{r}_u \times \vec{r}_v = \det \begin{pmatrix} \vec{i} & \vec{j} & \vec{k} \\ -R \sin u & R \cos u & 0 \\ 0 & 0 & 1 \end{pmatrix} = R \cos u \vec{i} + R \sin u \vec{j} + 0 \vec{k}.$$

So that $\sqrt{A^2 + B^2 + C^2} = R$ and $d\sigma = R du dv$. This means that if R is large enough, then the areas on the cylinder $x^2 + y^2 = R^2$ are very much modified. The dilation coefficient of the areas is R .

EXAMPLE 95. (conical deformation) Let $D = [0, 2\pi] \times [0, h]$ (see Fig.3) and let $\vec{r}(u, v) = \frac{R}{h}v \cos u \vec{i} + \frac{R}{h}v \sin u \vec{j} + v \vec{k}$, $u \in [0, 2\pi]$ and $v \in [0, h]$ be a deformation of the rectangle D onto a cone (see Fig.3).

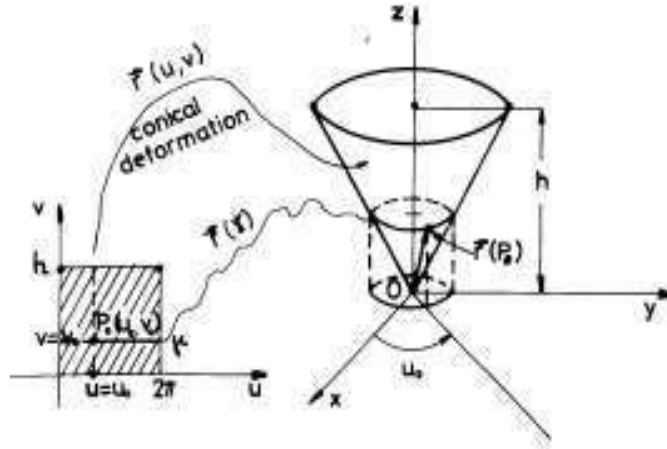

FIGURE 3

The Cartesian equation of this last cone is $x^2 + y^2 = \frac{R^2}{h^2} z^2$, $z \in [0, h]$. Let us compute the expression $\sqrt{A^2 + B^2 + C^2}$.

$$\begin{aligned} \vec{r}_u \times \vec{r}_v &= \det \begin{pmatrix} \vec{i} & \vec{j} & \vec{k} \\ -\frac{R}{h}v \sin u & \frac{R}{h}v \cos u & 0 \\ \frac{R}{h} \cos u & \frac{R}{h} \sin u & 1 \end{pmatrix} = \\ &= \frac{R}{h}v \cos u \vec{i} + \frac{R}{h}v \sin u \vec{j} - \frac{R^2}{h^2}v \vec{k}. \end{aligned}$$

Thus

$$\sqrt{A^2 + B^2 + C^2} = \sqrt{\frac{R^2}{h^2}v^2 + \frac{R^4}{h^4}v^2} = \frac{R}{h}v\sqrt{1 + \frac{R^2}{h^2}}.$$

Hence $d\sigma = \frac{R}{h}v\sqrt{1 + \frac{R^2}{h^2}}dudv$.

EXAMPLE 96. (spherical deformation) Let $D = [0, 2\pi] \times [0, \pi]$ (see Fig.4)

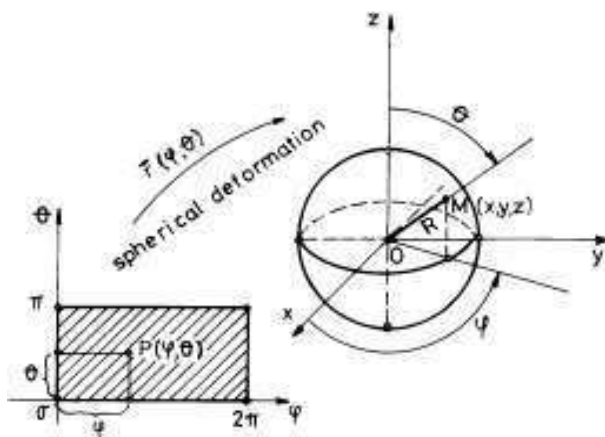

FIGURE 4

and let $\vec{r}(\varphi, \theta) = R \sin \theta \cos \varphi \vec{i} + R \sin \theta \sin \varphi \vec{j} + R \cos \theta \vec{k}$, $\varphi \in [0, 2\pi]$ and $\theta \in [0, \pi]$ be a deformation of the rectangle D onto the sphere $x^2 + y^2 + z^2 = R^2$. In this case,

$$\begin{aligned} \vec{r}_\varphi \times \vec{r}_\theta &= \det \begin{pmatrix} \vec{i} & \vec{j} & \vec{k} \\ -R \sin \theta \sin \varphi & R \sin \theta \cos \varphi & 0 \\ R \cos \theta \cos \varphi & R \cos \theta \sin \varphi & -R \sin \theta \end{pmatrix} = \\ &= -R^2 \sin^2 \theta \cos \varphi \vec{i} - R^2 \sin^2 \theta \sin \varphi \vec{j} - R^2 \sin \theta \cos \theta \vec{k}. \end{aligned}$$

Hence $\sqrt{A^2 + B^2 + C^2} = R^2 \sin \theta$.

In the case of a surface S which is explicitly given w.r.t. z , $z = z(x, y)$, the formulas can be putted in another more convenient form. Indeed, the parametrization of S is:

$$\begin{aligned} x &= x \\ y &= y \\ z &= z(x, y) \end{aligned}, (x, y) \in D.$$

Here x stands for u and y stands for v . Let us compute A , B and C in this particular case:

$$\vec{r}_x \times \vec{r}_y = \det \begin{pmatrix} \vec{i} & \vec{j} & \vec{k} \\ 1 & 0 & \frac{\partial z}{\partial x} \\ 0 & 1 & \frac{\partial z}{\partial y} \end{pmatrix} = -\frac{\partial z}{\partial x} \vec{i} - \frac{\partial z}{\partial y} \vec{j} + \vec{k}$$

Hence

$$(1.9) \quad A = -\frac{\partial z}{\partial x}, \quad B = -\frac{\partial z}{\partial y}, \quad C = 1.$$

Therefore

$$(1.10) \quad d\sigma = \sqrt{\left(\frac{\partial z}{\partial x}\right)^2 + \left(\frac{\partial z}{\partial y}\right)^2 + 1} dx dy$$

in this case.

2. Surface integral of the first type. The mass of a 3D-lamina.

Let D be a (general) plane domain like above (closed, bounded, connected and ∂D is a piecewise smooth) in the uov -plane. Let $\vec{r} : D \rightarrow \mathbb{R}^3$, $\vec{r}(u, v) = x(u, v)\vec{i} + y(u, v)\vec{j} + z(u, v)\vec{k}$ be a space piecewise smooth deformation of D onto a surface $S = \vec{r}(D)$. Let $f : S \rightarrow \mathbb{R}$ be a piecewise continuous function of variables x, y and z , defined on S . It will be called a *density function* for S . The pair (S, f) will be called a *3D-lamina (3-D plate)*. Let $\Delta = \{D_i\}$, $i = 1, 2, \dots, n$ be a division of nonoverlapping subdomains of the same type like D and let $\Delta^* = \{\vec{r}(D_i) \stackrel{def}{=} S_i\}$, $i = 1, 2, \dots, n$ be the corresponding division of the space surface S . Let $\{P_i(\xi_i, \eta_i)\}$, $P_i(\xi_i, \eta_i) \in D_i$ be a set of marking points for the division Δ and let $\{M_i(x(\xi_i, \eta_i), y(\xi_i, \eta_i), z(\xi_i, \eta_i))\}$, $i = 1, 2, \dots, n$ be the set of marking points of Δ^* which are the images of $\{P_i\}$ through the deformation \vec{r} . The norm of the division Δ is like usual the number $\|\Delta\| = \max\{diam(D_i) : i = 1, 2, \dots, n\}$. It is clear that $\|\Delta\| \rightarrow 0$ implies that $\|\Delta^*\| \rightarrow 0$. A Riemann sum for f, Δ^* and $\{M_i\}$ is defined as follows:

$$(2.1) \quad S_f(\Delta^*, \{M_i\}) = \sum_{i=1}^n f(x(\xi_i, \eta_i), y(\xi_i, \eta_i), z(\xi_i, \eta_i)) \cdot area(S_i).$$

A natural interpretation of this last sum is the following. The entire mass $mass(S)$ of the 3D-lamina (S, f) can be well approximated with the sum of all masses of the small homogenous 3D-laminas (S_i, f_i) , where for the density function f_i we take the constant function with

the same value $f(x(\xi_i, \eta_i), y(\xi_i, \eta_i), z(\xi_i, \eta_i))$ at any point of S_i , i.e. we approximated on S_i the variable density f with its value at a fixed point M_i of S_i . Thus the Riemann sum (2.1) is nothing else then the sum of the masses of all these new constructed laminas.

DEFINITION 29. *Let us preserve the above notation and definitions. We say that the function f is Riemann integrable on S if there exists a real number I such that for any small $\varepsilon > 0$, there exists a small $\delta > 0$ (which depends on ε) with the following property: if $\|\Delta^*\| < \delta$, then $|I - S_f(\Delta^*, \{M_i\})| < \varepsilon$ for any $P(\xi_i, \eta_i) \in D_i$. Hence I can be well approximated with Riemann sums of the type 2.1. This I can also be interpreted as the mass $\text{mass}(S)$, the mass of the 3D-lamina (S, f) , i.e. the mass of S with the density function f (when $f \geq 0$). The number I*

is denoted by $\iint_S f(x, y, z) d\sigma$ and we call it the surface integral of the first type of f on the surface S . In particular, for $f = 1$, we obtain the very useful formula: $\text{area}(S) = \iint_S d\sigma$. Like above, $d\sigma$ is said to be the element of area on S and it can be interpreted (a symbol in fact!) as an area of a very small surface S_i , when $\|\Delta^\| \rightarrow 0$.*

This number I is unique.

By using only this definition, it is possible to prove (prove them by imitating the similar proofs for double integrals!) the following main properties of the surface integral of the first type:

1) The mapping $f \rightsquigarrow \iint_S f(x, y, z) d\sigma$ is a linear mapping, i.e.

$$(2.2) \quad \iint_S [\alpha f(x, y, z) + \beta g(x, y, z)] d\sigma = \alpha \iint_S f(x, y, z) d\sigma + \beta \iint_S g(x, y, z) d\sigma.$$

2)

$$(2.3) \quad \int \int_{S=\cup_{i=1}^N S_i} f(x, y, z) d\sigma = \sum_{i=1}^N \iint_{S_i} f(x, y, z) d\sigma,$$

where $\{S_i\}$ are nonoverlapping surfaces.

3)

$$(2.4) \quad f \leq g \text{ implies } \iint_S f(x, y, z) d\sigma \leq \iint_S g(x, y, z) d\sigma,$$

in particular if $f \geq 0$, then $\iint_S f(x, y, z) d\sigma \geq 0$.

4) (a mean theorem)

$$(2.5) \quad \iint_S f(x, y, z) d\sigma = f(\xi, \eta, \theta) \cdot \text{area}(S),$$

where $M(\xi, \eta, \theta)$ is a point on S and f is assumed to be continuous.

5)

$$(2.6) \quad \text{area}(S) = \iint_S d\sigma$$

6)

$$\text{mass}(S) = \iint_S f(x, y, z) d\sigma,$$

where f is a density function on S .

7) The coordinates of the mass centre of the 3D-lamina (S, f) are calculated with the help of the following formulas:

(2.7)

$$x_G = \frac{\iint_S x f(x, y, z) d\sigma}{\iint_S f(x, y, z) d\sigma}, \quad y_G = \frac{\iint_S y f(x, y, z) d\sigma}{\iint_S f(x, y, z) d\sigma}, \quad z_G = \frac{\iint_S z f(x, y, z) d\sigma}{\iint_S f(x, y, z) d\sigma}.$$

8) Let (d) be a straight line in space and let $g(x, y, z)$ be the distance-function of a point $M(x, y, z)$ up to (d) . Let S be a surface in space and let (S, f) be a 3D-lamina. Then the moment of inertia of (S, f) w.r.t. to (d) (when S rotates around (d)) is:

$$(2.8) \quad I_{(d)} = \iint_S g^2(x, y, z) f(x, y, z) d\sigma.$$

In particular, if (d) is the Oz -axis, then

$$I_z = \iint_S (x^2 + y^2) \cdot f(x, y, z) d\sigma.$$

Now we shall see how to practically compute such surface integrals of the first type. They are in fact the 2-dimensional variants of the line integrals of the first type (see definition 17).

THEOREM 94. Let (S, f) be a 3D-lamina as above (D is a general plane domain, $\vec{r} : D \rightarrow \mathbb{R}^3$ is a piecewise smooth deformation of D onto S , f is piecewise continuous density function on S). Then we can reduce the computation of $I = \iint_S f(x, y, z) d\sigma$ to the computation of a double integral on the initial undeformed domain D :

$$(2.9) \quad \iint_S f(x, y, z) d\sigma =$$

$$= \iint_D f(x(u, v), y(u, v), z(u, v)) \sqrt{A(u, v)^2 + B(u, v)^2 + C(u, v)^2} du dv.$$

We simply substituted the independent variables x, y, z with the deformation functions $x(u, v)$, $y(u, v)$, $z(u, v)$ and finally we putted instead of $d\sigma$ its expression from formula 1.5.

PROOF. The proof is based on the same idea like the leading idea of all the proofs for obtaining change of variables formulas. We well approximate D with a finite union $\cup_{j=1}^N R_j \subset D$ of nonoverlapping simple rectangles $\{R_i\}$. Let $R_i^* = \vec{r}(R_i)$ be the image of R_i through the deformation \vec{r} . Because of the hypotheses on D and on the deformation \vec{r} of D onto S , the union $\cup_{j=1}^N R_j^*$ well approximate S and the curvilinear parallelograms R_j^* are nonoverlapping figures. Thus,

$$(2.10) \quad \iint_S f(x, y, z) d\sigma \approx \sum_{j=1}^N f(x(\xi_j, \eta_j), y(\xi_j, \eta_j), z(\xi_j, \eta_j)) \cdot \text{area}(R_j^*),$$

where $\{P_j(\xi_j, \eta_j) \in R_j\}$ is a set of marking points in D . But theorem 93 applied to $\text{area}(R_j^*)$ transforms the last sum of the formula (2.10) into a sum which approximates the double integral of (2.9):

$$\sum_{j=1}^N f(x(\xi_j, \eta_j), y(\xi_j, \eta_j), z(\xi_j, \eta_j)) \cdot \text{area}(R_j^*) \approx$$

$$\approx \sum_{j=1}^N f(x(\xi_j, \eta_j), y(\xi_j, \eta_j), z(\xi_j, \eta_j)) \times$$

$$\times \sqrt{A(\xi_j, \eta_j)^2 + B(\xi_j, \eta_j)^2 + C(\xi_j, \eta_j)^2} \cdot \text{area}(R_j) \approx$$

$$\approx \iint_D f(x(u, v), y(u, v), z(u, v)) \sqrt{A(u, v)^2 + B(u, v)^2 + C(u, v)^2} du dv.$$

Hence,

$$\begin{aligned} \iint_S f(x, y, z) d\sigma &\approx \\ &\approx \iint_D f(x(u, v), y(u, v), z(u, v)) \sqrt{A(u, v)^2 + B(u, v)^2 + C(u, v)^2} du dv. \end{aligned}$$

Since both these numbers are fixed numbers, they must coincide, i.e. the equality (2.9) is completely proved. \square

We can now compute different quantities which are expressed by surface integrals of the first type.

EXAMPLE 97. Let $S : x^2 + y^2 = 2z$, $0 \leq z \leq 2$ be a paraboloid (see Fig. 5).

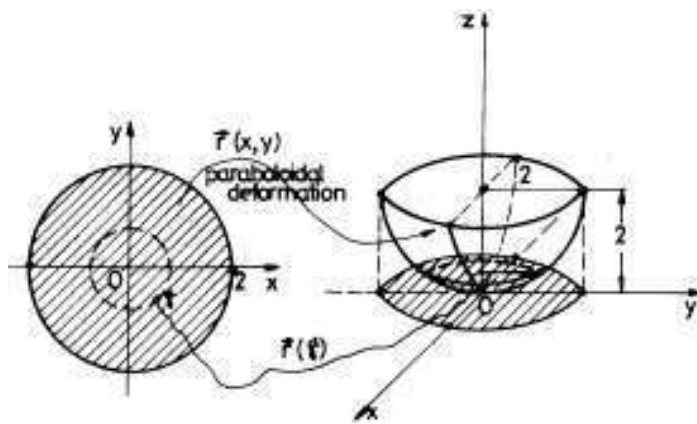

FIGURE 5

It is realized as the image of disc $x^2 + y^2 \leq 4$ of radius 2 and centre at O (see Fig. 5), through the deformation $\vec{r}(x, y) = x \vec{i} + y \vec{j} + \frac{x^2 + y^2}{2} \vec{k}$. Since a parametrization for S is explicitly expressed w.r.t. z , $z(x, y) = \frac{x^2 + y^2}{2}$, we can apply formula (1.10) and find

$$(2.11) \quad d\sigma = \sqrt{\left(\frac{\partial z}{\partial x}\right)^2 + \left(\frac{\partial z}{\partial y}\right)^2 + 1} dx dy = \sqrt{x^2 + y^2 + 1} dx dy.$$

a) Let us compute $\text{area}(S)$.

$$\begin{aligned} \text{area}(S) &= \iint_S d\sigma = \int_{D:x^2+y^2 \leq 4} \int \sqrt{x^2 + y^2 + 1} dx dy = \\ & \stackrel{x=\rho \cos \theta}{x=\rho \sin \theta} \int_0^2 \rho \sqrt{\rho^2 + 1} \left(\int_0^{2\pi} d\theta \right) d\rho = \\ &= \pi \int_0^2 (\rho^2 + 1)^{\frac{1}{2}} d(\rho^2 + 1) = \pi \left. \frac{(\rho^2 + 1)^{\frac{3}{2}}}{\frac{3}{2}} \right|_0^2 = \frac{2\pi}{3} (5^{3/2} - 1). \end{aligned}$$

b) Find its mass, if the density function is $f(x, y, z) = 3z$.

$$\begin{aligned} \text{mass}(D) &= \iint_S f(x, y, z) d\sigma = \frac{3}{2} \int_{D:x^2+y^2 \leq 4} \int (x^2 + y^2) \sqrt{x^2 + y^2 + 1} dx dy = \\ &= \frac{3}{2} \cdot 2\pi \int_0^2 \rho^3 \sqrt{\rho^2 + 1} d\rho \stackrel{\rho^2+1=t^2}{=} 3\pi \int_1^{\sqrt{5}} t^2(t^2 - 1) dt = \text{etc.} \end{aligned}$$

c) Find the moment of inertia of (S, f) , $f = 3z$, around the Ox -axis.

$$\begin{aligned} I_x &= 3 \iint_S \frac{x^2 + y^2}{2} \left(y^2 + \frac{(x^2 + y^2)^2}{4} \right) \sqrt{1 + x^2 + y^2} dx dy = \\ &= \frac{3}{8} \int_0^2 \rho^3 \sqrt{\rho^2 + 1} \left(\int_0^{2\pi} [4\rho^2 \sin^2 \theta + \rho^4] d\theta \right) d\rho = \\ (2.12) \quad &= \frac{3}{2} \int_0^2 \rho^5 \sqrt{\rho^2 + 1} \left(\int_0^{2\pi} \sin^2 \theta d\theta \right) d\rho + \frac{3\pi}{4} \int_0^2 \rho^7 \sqrt{\rho^2 + 1} d\rho. \end{aligned}$$

But

$$\int_0^{2\pi} \sin^2 \theta d\theta = \int_0^{2\pi} \frac{1 - \cos 2\theta}{2} d\theta = \pi,$$

so that 2.12 becomes

$$I_x = \frac{3\pi}{2} \int_0^2 \rho^5 \sqrt{\rho^2 + 1} d\rho + \frac{3\pi}{4} \int_0^2 \rho^7 \sqrt{\rho^2 + 1} d\rho = \text{etc.}$$

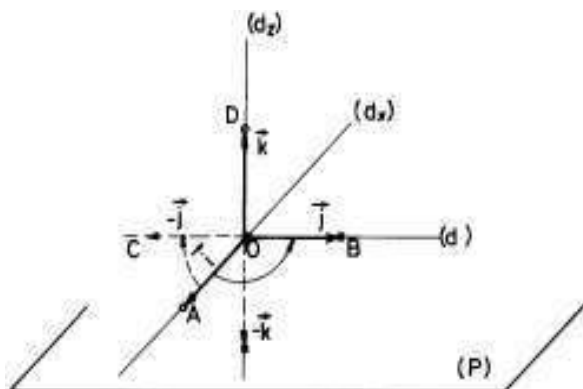

FIGURE 6

3. Flux of a vector field through an oriented surface.

Let us consider a plane (P) and a fixed point O (the origin) in it. Let (d_x) be an oriented line in (P) which passes through O . Let (d_y) be another oriented line in (P) which also passes through O and is perpendicular on (d_x) at O (see Fig.6).

In fact we have two possibilities to orientate (by fixing a nonzero vector or "an arrow" with the support line parallel to (d_y) !) this last line (d_y) . One is given by a vector \overrightarrow{OB} (see Fig.6) and the other is defined by the vector $\overrightarrow{OC} = -\overrightarrow{OB}$. If we put a screw at O , perpendicular on (P) and, if we rotate it from \overrightarrow{OA} to \overrightarrow{OB} around O on the "smallest path" ($= 90^\circ$), the direction of its advancement gives rise to another oriented line (d_z) which is perpendicular on (d_x) and (d_y) . This means that the direction of (d_z) is given by the vector $\overrightarrow{OD} = \overrightarrow{OA} \times \overrightarrow{OB}$, i.e. we just obtained "the up" part of the plane (P) . "The down" part of (P) is given by $-\overrightarrow{OD}$. Let \vec{i} , \vec{j} and \vec{k} be the versors of \overrightarrow{OA} , \overrightarrow{OB} and \overrightarrow{OD} respectively (see Fig.6). If one chooses the other orientation of (d_y) , given by \overrightarrow{OC} and, if one rotates the screw from \overrightarrow{OA} to \overrightarrow{OC} , it advances on the other direction of \vec{k} , i.e. on the direction of $-\vec{k}$. The Cartesian coordinate system $\{O; \vec{i}, \vec{j}, \vec{k}\}$ is said to be *direct or right oriented* and the other $\{O; \vec{i}, \vec{j}, -\vec{k}\}$ is called *inverse or left oriented*. Thus our plane (P) has two "faces": one which corresponds to \vec{k} (as a free vector if O runs on the plane) and the other which corresponds to $-\vec{k}$. This implies that if we move continuously O along a closed oriented (see definition 18) smooth curve $(\gamma) \subset (P)$, the vector \vec{k} (fixed in O) is moving on this curve and comes back at the same initial position.

We can observe that if we continuously move the plane Cartesian coordinate system $\{O; \vec{i}, \vec{j}\}$ in the plane (P) , we never can reach the position of the Cartesian coordinate system $\{O; \vec{i}, -\vec{j}\}$. This is why we call $\{O; \vec{i}, \vec{j}\}$ a direct oriented plane Cartesian coordinate system and the other, $\{O; \vec{i}, -\vec{j}\}$, an inverse orientated Cartesian coordinate system.

The definition of a direct or inverse orientation of a Cartesian coordinate system does not depend on the position of the point O , but on the basis of vectors $\{\vec{i}, \vec{j}, \vec{k}\}$. This is why the true mathematical model of "orientation" is connected to the bases of the 3D-vector space of free vectors. We say that two basis of vectors $\{v_1, v_2, v_3\}$ and $\{w_1, w_2, w_3\}$ have the same orientation if the matrix $C = (c_{ij})$, constructed as follows:

$$\begin{aligned} w_1 &= c_{11}v_1 + c_{21}v_2 + c_{31}v_3 \\ w_2 &= c_{12}v_1 + c_{22}v_2 + c_{32}v_3 \\ w_3 &= c_{13}v_1 + c_{23}v_2 + c_{33}v_3, \end{aligned}$$

(called the *transition matrix* from the basis $\{v_1, v_2, v_3\}$ to the basis $\{w_1, w_2, w_3\}$) has its determinant $\det C$ a positive real number. The infinite set of all the bases in V_3 , the real vector space of all 3D-free vectors, can be divided into two nonoverlapping (their intersection is empty) subsets A and A^- . Two bases $\{v_1, v_2, v_3\}$ and $\{w_1, w_2, w_3\}$ belongs to the same subset if the transition matrix from one to another has a positive determinant. Let denote by A the subset (or class) which contains the basis $\{\vec{i}, \vec{j}, \vec{k}\}$ and by A^- the subset (or class) which contains the basis $\{\vec{i}, \vec{j}, -\vec{k}\}$. We leave as an exercise for the reader to prove that $A \cup A^-$ contains all the bases of V_3 and that $A \cap A^- = \emptyset$, the empty set. We call A the direct orientation of the space V_3 and A^- the inverse orientation of V_3 . The same can be done for V_2 , the real vector space of the 2D-free vector space (i.e. the plane free vectors). Thus, whenever we fix a Cartesian coordinate system uov in a plane (P) , we just fixed a direct orientation: "from u to v ". What is this? The direction of the ou -axis is given by a versor \vec{i}' . The direction of ov -axis is given by a versor \vec{j}' . By definition the class A of orientation into which the base $\{\vec{i}', \vec{j}'\}$ belongs is said to be the direct orientation of the Cartesian system uov . "From u to v " means that we take firstly \vec{i}' then, secondly, we take \vec{j}' . We simply say that uov is an oriented plane Cartesian coordinate system (here the direct orientation is "from u to v " and the inverse one is "from v to u ") (see Fig.7). The closed

curve in the uov -plane of Fig.7 is direct oriented because "its direction" or "its arrow" is "from u to v ", the trigonometric direction or the counterclockwise direction. Let D be a plane general domain (closed, bounded, connected and ∂D an oriented piecewise smooth curve). Being in the plane uov , we say that D is oriented by this plane. More exactly, ∂D is directly oriented as we can see in Fig.7. If we walk on ∂D in the direction of ∂D , the plane domain D must remain on the left side. This last quality makes D to be an oriented domain.

Let $\vec{g}(u, v) = x(u, v)\vec{i} + y(u, v)\vec{j} + z(u, v)\vec{k}$ be a smooth deformation (see its exact definition in Section 1, this chapter) defined on an oriented (like above!) general domain D , with values in V_3 (or in \mathbb{R}^3). Let $(S) = \vec{g}(D)$ be the surface defined by this deformation. Let $P_0(u_0, v_0)$ be a point in D and let the direct orientated "coordinate curves" $\gamma_u : v = v_0$ and $\gamma_v : u = u_0$ which are passing through P_0 (see Fig.7). Let $M_0 = \vec{g}(P_0)$ and let Γ_u and Γ_v be the images on the surface (S) of γ_u and γ_v , respectively. We assume that the curves Γ_u and Γ_v are also oriented with the same orientation like that one transported from γ_u and γ_v , respectively (see Fig.7). Γ_u and Γ_v are called the coordinate curves on (S) which pass through M_0 . Thus,

$$(3.1) \quad \Gamma_u : \begin{cases} x = x(u, v_0) \\ y = y(u, v_0) \\ z = z(u, v_0) \end{cases}, u \in pr_{ou-axis}(D);$$

$$\Gamma_v : \begin{cases} x = x(u_0, v) \\ y = y(u_0, v) \\ z = z(u_0, v) \end{cases}, v \in pr_{ov-axis}(D).$$

Hence, the "velocity" along Γ_u is

$$\vec{r}_u = \frac{\partial \vec{r}}{\partial u} = \left(\frac{\partial x}{\partial u}, \frac{\partial y}{\partial u}, \frac{\partial z}{\partial u} \right)$$

and the "velocity" along Γ_v is

$$\vec{r}_v = \frac{\partial \vec{r}}{\partial v} = \left(\frac{\partial x}{\partial v}, \frac{\partial y}{\partial v}, \frac{\partial z}{\partial v} \right).$$

We associate to the point $M_0 \in (S)$ its normal versor

$$\vec{n}(M_0) = \frac{\vec{r}_u(u_0, v_0) \times \vec{r}_v(u_0, v_0)}{\|\vec{r}_u(u_0, v_0) \times \vec{r}_v(u_0, v_0)\|}$$

on (S) (see Fig.7). Here, in the definition of $\vec{n}(M_0)$, we have incorporated the orientation of D namely, we see that in the cross product of the numerator we take $\vec{r}_u(M_0)$, then $\vec{r}_v(M_0)$, i.e. "from u to v ". Since $\vec{n}(M_0)$ is a versor, it uniquely defines a point M_0^* (its extremity

if $\vec{n}(M_0) = \overrightarrow{OM_0^*}$ on the unit sphere $(US) : x^2 + y^2 + z^2 = 1$ in the $Oxyz$ -space (the space into which (S) is considered). Let us leave M_0 to run freely on (S) and let us denote it by M . We obtain in this way a new function $M \rightsquigarrow M^*$, which associates to a point M of (S) , a point M^* on (US) . Let us call this function the *orientation function* and denote it by $Or : (S) \rightarrow (US)$, $Or(M) = M^*$.

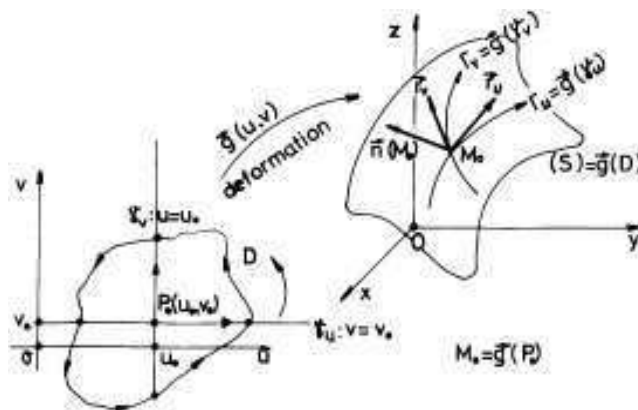

FIGURE 7

DEFINITION 30. Let us preserve all of these notation and hypotheses like above. If the vector function $Or : (S) \rightarrow (US)$, $Or(M) = M^*$, is a continuous function, we say that our surface (S) is orientable. This function defines the direct (right) orientation ("from u to v ") or the direct face of (S) . The function $Or^- : (S) \rightarrow (US)$, $Or^-(M) = -M^*$, the symmetric of M w.r.t. the origin O , is also continuous if Or is continuous and it defines the inverse (left) orientation ("from v to u ") or the reverse face of (S) . The continuity of Or means that if a point M starts from a fixed point $M_0 \in (S)$ and runs on any continuous "closed" curve $\gamma \subset (S)$ which contains M_0 , then the normal vector $\vec{n}(M)$, which starts from $\vec{n}(M_0)$, after covering the entire curve γ , it comes back to its initial position $\vec{n}(M_0)$. Then we say that (S) has two distinct faces, i.e. it is orientable. Moreover, we also see that the orientation function Or is continuous if the deformation $\vec{g} : D \rightarrow \vec{g}(D) = (S)$ has a continuous inverse and if $Or \circ \vec{g} : D \rightarrow (US)$ is continuous. This is the case for instance when we can find an explicit parameterization of \vec{g} and $Or \circ \vec{g}$ is continuous.

EXAMPLE 98. For instance, a plane $(P) : ax + by + cz + d = 0$ is an orientable surface. Indeed, say $a \neq 0$, $a > 0$ and let us use the

following explicit w.r.t. x parametrization

$$\begin{aligned} x &= -\frac{by+cz+d}{a} \\ y &= y \\ z &= z \end{aligned}, (y, z) \in \mathbb{R}^2.$$

Let us consider \mathbb{R}^2 with the oriented yOz -Cartesian coordinate system ("from y to z "). Since

$$\vec{r}_y \times \vec{r}_z = \det \begin{pmatrix} \vec{i} & \vec{j} & \vec{k} \\ -\frac{b}{a} & 1 & 0 \\ -\frac{c}{a} & 0 & 1 \end{pmatrix} = \vec{i} + \frac{b}{a}\vec{j} + \frac{c}{a}\vec{k},$$

then $\vec{n}(M) = \frac{\vec{i} + \frac{b}{a}\vec{j} + \frac{c}{a}\vec{k}}{\sqrt{1 + \frac{b^2}{a^2} + \frac{c^2}{a^2}}} = \frac{a\vec{i} + b\vec{j} + c\vec{k}}{\sqrt{a^2 + b^2 + c^2}}$. Thus, the orientation function becomes:

$$\left(-\frac{by+cz+d}{a}, y, z \right) \rightarrow \left(\frac{a}{\sqrt{a^2 + b^2 + c^2}}, \frac{b}{\sqrt{a^2 + b^2 + c^2}}, \frac{c}{\sqrt{a^2 + b^2 + c^2}} \right),$$

i.e. a constant function, which always is continuous. Therefore, any plane has two faces, i.e. it is orientable.

Not all surfaces are orientable, i.e. they have two faces. An easy to construct surface which has only one face is Möbius surface (see Fig.8). This surface is obtained by taking a rectangle strip $[ABCD]$ and by gluing $[AB]$ with $[BC]$ such that $A \equiv C$ and $B \equiv D$. Let (γ) be the "closed" curve which was initially the midline in the rectangle $[ABCD]$ (see Fig.8). Let us continuously and increasingly move a normal vector \vec{n} along (γ) by starting from M . We see that whenever we come back to M the initial vector \vec{n} becomes $-\vec{n}$. Thus, the orientation function $M \rightsquigarrow \vec{n}(M) \rightsquigarrow M^* \in (US)$ is not continuous. Hence this surface cannot be orientable, i.e. it has only one face (one cannot separate two distinct faces of it!).

A natural question arises. Is it possible to find a "special" parametrization for this Möbius surface such that it be orientable? It can be proved that this last possibility cannot appear. To be or not to be orientable does not depend on a particular parameterization of a surface S . But, it is possible to change the direct face of (S) with the inverse one, if we change the initial parametrization of (S) with another one. For instance, let us consider the same plane $(P) : ax + by + cz + d = 0$, $a > 0$, as in example 98 with the following parametrization:

$$\begin{aligned} x &= -\frac{-bu+cv+d}{a} \\ y &= -u \\ z &= v \end{aligned}, (u, v) \in \mathbb{R}^2.$$

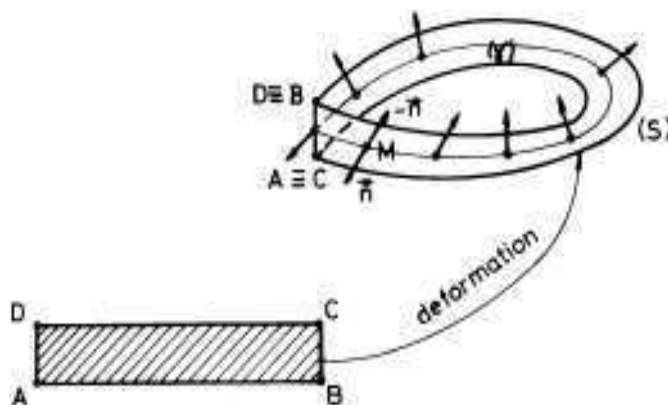

FIGURE 8

It is easy to see that $\vec{n}(M) = -\frac{a\vec{i}+b\vec{j}+c\vec{k}}{\sqrt{a^2+b^2+c^2}}$, i.e. the normal versor of the other side. Let (S) be a surface with two equivalent parametrizations $\vec{g} : D \rightarrow (S)$ and $\vec{g}' : D' \rightarrow (S)$. Then there exists a diffeomorphism $\phi : D' \rightarrow D$ such that $\vec{g}' = \vec{g} \circ \phi$. It is easy to prove that \vec{g} and \vec{g}' defines one and the same face if and only if the Jacobian of ϕ is a positive number.

In general, if a surface (S) has an explicit parametrization, say w.r.t. z ,

$$(S) : \begin{cases} x = x \\ y = y \\ z = z(x, y) \end{cases}, (x, y) \in D \subset xOy,$$

then $A = -\frac{\partial z}{\partial x}$, $B = -\frac{\partial z}{\partial y}$ and $C = 1$ (see formula (1.9)). Since

$$\begin{aligned} (3.2) \quad \vec{n}(M) &= \cos \alpha \vec{i} + \cos \beta \vec{j} + \cos \gamma \vec{k} = \\ &= \frac{A(u, v)}{\sqrt{A(u, v)^2 + B(u, v)^2 + C(u, v)^2}} \vec{i} + \\ &+ \frac{B(u, v)}{\sqrt{A(u, v)^2 + B(u, v)^2 + C(u, v)^2}} \vec{j} + \\ &+ \frac{C(u, v)}{\sqrt{A(u, v)^2 + B(u, v)^2 + C(u, v)^2}} \vec{k}, \end{aligned}$$

then $\cos \gamma = \frac{1}{\sqrt{A^2+B^2+1}} > 0$ i.e. $\gamma \in [0, \frac{\pi}{2})$. Many times, this last information is sufficient to determine the direct face (which corresponds to the direct orientation) of the surface (S) .

EXAMPLE 99. Let $(S) : \begin{cases} x = x \\ y = y \\ z = \sqrt{x^2 + y^2} \end{cases}, x^2 + y^2 \leq R^2$ be the conic surface of Fig.9.

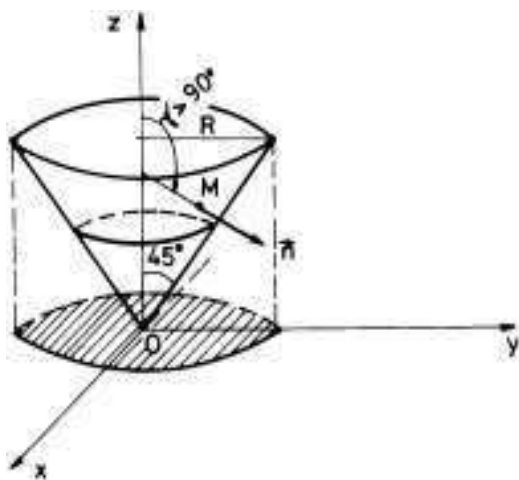

FIGURE 9

We are interested to find the mathematical description of the normal vectors \vec{n} which define the exterior side of this conic surface (see \vec{n} in Fig.9). The angle γ between \vec{n} and Oz is greater than 90° , so that $\cos \gamma < 0$, i.e.

$$\cos \gamma = -\frac{1}{\sqrt{A(u, v)^2 + B(u, v)^2 + 1}}.$$

Hence, we must put a minus in front of $\cos \alpha$, $\cos \beta$ and $\cos \gamma$, in the expression of \vec{n} (see (3.2)). Therefore, in our case, for any $M(x, y, z) \in (S)$,

$$\vec{n}(M) = \left(\frac{x}{\sqrt{2}\sqrt{x^2 + y^2}}, \frac{y}{\sqrt{2}\sqrt{x^2 + y^2}}, -\frac{1}{\sqrt{2}} \right).$$

REMARK 34. It is not difficult to see that if D is a smooth domain (closed, bounded, connected and ∂D is a smooth curve) and if $\vec{r} : D \rightarrow \vec{r}(D) = (S)$ is a smooth deformation of D onto the surface (S) (\vec{r} is of class C^1 , injective and $\vec{r}_u \times \vec{r}_v \neq 0$ on D), then (S) is orientable.

Let now D be a closed, bounded and connected subset of the uov -plane with its boundary ∂D a piecewise directed oriented curve in uov . Let $D = \cup_{i=1}^n D_i$ be a division of D with nonoverlapping ($D_i \cap D_j$ has a

zero area for $i \neq j$) oriented subdomains of the same type like D (see Fig.10). We see in this figure that the intersection curve $D_i \cap D_j$ (if it exist like a curve!) is always double oriented. Moreover, the orientation of each D_i (i.e. the orientation of ∂D_i) is completely determined by the orientation of D (i.e. of ∂D).

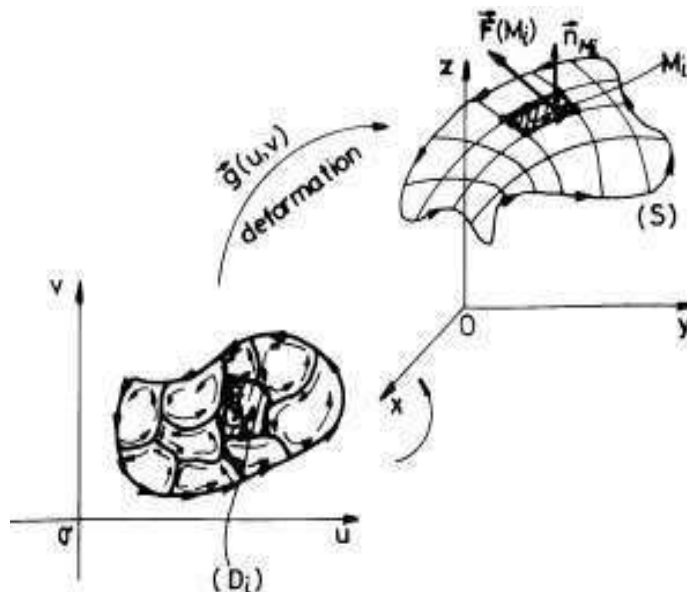

FIGURE 10

Let $\vec{r}(u, v) = x(u, v)\vec{i} + y(u, v)\vec{j} + z(u, v)\vec{k}$, $\vec{r} : D \rightarrow \vec{g}(D) = (S)$ be a piecewise smooth deformation and let $P_i(u_i, v_i) \in D_i$, $i = 1, 2, \dots, n$ be a set of marking points of the division $\{D_i\}$ of D . Then $\{S_i = \vec{g}(D_i)\}$, $i = 1, 2, \dots, n$ is a division of (S) . If

$$\|\{D_i\}\| = \max\{\text{diam}(D_i) : i = 1, 2, \dots, n\}$$

becomes smaller and smaller, then $\|\{S_i\}\|$ becomes smaller and smaller, except maybe a subset of points of zero area of D . Let $M_i = \vec{r}(P_i)$, i.e. $M_i(x(u_i, v_i), y(u_i, v_i), z(u_i, v_i))$ for $i = 1, 2, \dots, n$. We assume that (S) and, as a consequence, all (S_i) are orientable surfaces. Let

$$\begin{aligned} \vec{n}(M_i) &= \frac{\vec{r}_u(u_i, v_i) \times \vec{r}_v(u_i, v_i)}{\|\vec{r}_u(u_i, v_i) \times \vec{r}_v(u_i, v_i)\|} = \\ (3.3) \quad &= \frac{A(u_i, v_i)}{\sqrt{A(u_i, v_i)^2 + B(u_i, v_i)^2 + C(u_i, v_i)^2}} \vec{i} + \end{aligned}$$

$$\begin{aligned}
& + \frac{B(u_i, v_i)}{\sqrt{A(u_i, v_i)^2 + B(u_i, v_i)^2 + C(u_i, v_i)^2}} \vec{j} + \\
& + \frac{C(u_i, v_i)}{\sqrt{A(u_i, v_i)^2 + B(u_i, v_i)^2 + C(u_i, v_i)^2}} \vec{k},
\end{aligned}$$

be the normal versor at M_i , which belongs to the direct orientation of (S) . Let $\vec{F} : (S) \rightarrow \mathbb{R}^3$, $\vec{F}(x, y, z) = P(x, y, z) \vec{i} + Q(x, y, z) \vec{j} + R(x, y, z) \vec{k}$, be a field of vectors of class C^1 almost everywhere on (S) , i.e. the subset of (S) on which \vec{F} is not of class C^1 has zero area. The impact of the force $\vec{F}(M)$ with the surface (S) at the point $M \in (S)$ is measured by the projection of this force $\vec{F}(M)$ on the normal versor $\vec{n}(M)$, i.e. $\vec{F}(M) \cdot \vec{n}(M)$ (dot product). This quantity is called the *flux of the vector $\vec{F}(M)$ through the surface (S) , at the point M* . If the diameter of (S_i) is small enough, we can approximate it with a plane surface, which can be viewed as a part of the tangent plane of (S) at the fixed point $M_i \in (S_i)$. We also approximate $\vec{F}(M)$ with the constant vector $\vec{F}(M_i)$ for any point $M \in (S_i)$. Thus, the flux $\vec{F}(M) \cdot \vec{n}(M)$ at M can be approximated with the flux $\vec{F}(M_i) \cdot \vec{n}(M_i)$ at M_i . Therefore, the total flux on (S_i) can be approximated with $\left[\vec{F}(M_i) \cdot \vec{n}(M_i) \right] \cdot \text{area}(S_i)$ (here the first " \cdot " means the dot product but the second " \cdot " means the usual multiplication between two real numbers). This last number is the volume of a right cylinder with the basis (S_i) and the height $\vec{F}(M_i) \cdot \vec{n}(M_i)$. Hence, the global flux $\Phi_{(S)}(\vec{F})$ of the field \vec{F} through the oriented (S) can be well approximated with the following Riemann sum:

$$(3.4) \quad S_{\vec{F},(S)}(\{S_i\}, \{M_i\}) = \sum_{i=1}^n \left[\vec{F}(M_i) \cdot \vec{n}(M_i) \right] \cdot \text{area}(S_i).$$

DEFINITION 31. \vec{F} is integrable on the direct oriented surface (S) if there exists a real number I such that for any small real number $\varepsilon > 0$, one can find another small real number $\delta > 0$ (which depends on ε) such that if $\{D_i\}$ is a division of D with $\|\{D_i\}\| < \delta$, then $\left| I - S_{\vec{F},(S)}(\{S_i\}, \{M_i\}) \right| < \varepsilon$ for any set of marking points $\{P_i\}$, $P_i \in D_i$. I is called the surface integral of the second type of \vec{F} on the oriented surface (S) . It is denoted by $\oint \oint_{(S)^+} \vec{F} \cdot \vec{n} d\sigma$. The sign "+"

means that the integral is considered on the direct face of (S) . Whenever we write $\oint\limits_{(S)} \vec{F} \cdot \vec{n} d\sigma$, we must understand that the matter is about the direct face of (S) .

Hence, we can well approximate I with Riemann sums of the form (3.4). This last number I can be interpreted as the "global" flux of the field \vec{F} through the oriented surface (S) , considered with its direct face (or with its direct orientation "from u to v "). The surface integral of the second type is the analogous notion in the 2-dimensional case of the line integral of the second type for oriented curves (this last line integral is an 1-dimensional object).

Using only this definition, we can easily prove (do it!) the following basic properties of the surface integrals of the second type.

1) $\oint\limits_{(S)^-} \vec{F} \cdot \vec{n} d\sigma = - \oint\limits_{(S)^+} \vec{F} \cdot \vec{n} d\sigma$, where $(S)^-$ means the surface (S) with its inverse orientation ("from v to u "). To see this one can change $\vec{n}(M_i)$ with $-\vec{n}(M_i)$ in the above Riemann sums.

2) The mapping $\vec{F} \rightsquigarrow \oint\limits_{(S)} \vec{F} \cdot \vec{n} d\sigma$ is a linear mapping, i.e.

$$\oint\limits_{(S)} (\alpha \vec{F} + \beta \vec{G}) \cdot \vec{n} d\sigma = \alpha \oint\limits_{(S)} \vec{F} \cdot \vec{n} d\sigma + \beta \oint\limits_{(S)} \vec{G} \cdot \vec{n} d\sigma.$$

3)

$$\oint\limits_{(S) \cup (T)} \vec{F} \cdot \vec{n} d\sigma = \oint\limits_{(S)} \vec{F} \cdot \vec{n} d\sigma + \oint\limits_{(T)} \vec{F} \cdot \vec{n} d\sigma,$$

where (T) is another oriented surface such that on the common curve $\partial(S) \cap \partial(T)$ the orientation induced by the orientation of (T) must be the inverse orientation of the same intersection curve viewed with the orientation induced by the orientation of (S) (see the situation of two neighboring oriented subdomains in Fig.10 or in Fig.13). If the surfaces (S) and (T) have no small smooth curve in common, then the orientation of (T) cannot be connected with the orientation of (S) by anything else, so that in the union $(S) \cup (T)$ they keep their own orientation.

Let us now try to prove the existence and to compute the surface integral of the second type $\oint\limits_{(S)} \vec{F} \cdot \vec{n} d\sigma$. For this we approximate the

area of (S_i) in formula (3.4) by using formula (1.5):

$$(3.5) \quad \text{area}(S_i) \approx \sqrt{A(u_i, v_i)^2 + B(u_i, v_i)^2 + C(u_i, v_i)^2} \text{area}(D_i).$$

We can also prove such a formula by the use of formula (2.9) and the mean theorem for double integrals:

$$\begin{aligned} \text{area}(S_i) &= \iint_{(S_i)} d\sigma = \iint_{D_i} \sqrt{A(u, v)^2 + B(u, v)^2 + C(u, v)^2} dudv = \\ &= \sqrt{A(u^*, v^*)^2 + B(u^*, v^*)^2 + C(u^*, v^*)^2} \iint_{D_i} dudv \approx \\ &\approx \sqrt{A(u_i, v_i)^2 + B(u_i, v_i)^2 + C(u_i, v_i)^2} \text{area}(D_i), \end{aligned}$$

because both points $P_i(u_i, v_i)$ and $P_i^*(u^*, v^*)$ are in the same small domain D_i . Let us come back in formula (3.4) with this expression of the $\text{area}(S_i)$ and with the expression of $\vec{n}(M_i)$ from formula (3.3):

$$\begin{aligned} &\sum_{i=1}^n \left[\vec{F}(M_i) \cdot \vec{n}(M_i) \right] \cdot \text{area}(S_i) \approx \\ &\approx \sum_{i=1}^n [P(M_i)A(M_i) + Q(M_i)B(M_i) + R(M_i)C(M_i)] \text{area}(D_i). \end{aligned}$$

But this last sum is a Riemann sum of the double integral

$$\begin{aligned} &\iint_D [P(x(u, v), y(u, v), z(u, v))A(u, v) + Q(x(u, v), y(u, v), z(u, v))B(u, v) + \\ &\quad + R(x(u, v), y(u, v), z(u, v))C(u, v)] dudv. \end{aligned}$$

Since this last double integral and I , the surface integral of the second type

$$\oint \oint_{(S)} \vec{F} \cdot \vec{n} d\sigma, \text{ can be well approximated by the same Riemann}$$

sums, we must conclude that they must be equal, i.e.

$$\begin{aligned} &\oint \oint_{(S)} \vec{F} \cdot \vec{n} d\sigma = \\ (3.6) &= \iint_D [P(x(u, v), y(u, v), z(u, v))A(u, v) + Q(x(u, v), y(u, v), z(u, v))B(u, v) + \\ &\quad + R(x(u, v), y(u, v), z(u, v))C(u, v)] dudv. \end{aligned}$$

Thus we just reduced the computation of a surface integral of the second type to the calculation of a double integral. If we want to change the face of (S) , we must put a minus sign in front of the above double integral. We can also express (prove it!) the surface integral of the second type as a surface integral of the first type:

$$(3.7) \quad \oint_{(S)} \vec{F} \cdot \vec{n} \, d\sigma = \iint_{(S)} [P(x, y, z) \cos \alpha + Q(x, y, z) \cos \beta + R(x, y, z) \cos \gamma] \, d\sigma,$$

where $\cos \alpha$, $\cos \beta$ and $\cos \gamma$ are the coordinates of the normal vector $\vec{n}(M)$ at the point $M(x, y, z)$. This is not a practical formula. But it is useful in order to find a new expression for the surface integral

$$\oint_{(S)} \vec{F} \cdot \vec{n} \, d\sigma. \text{ If we look at Fig.11}$$

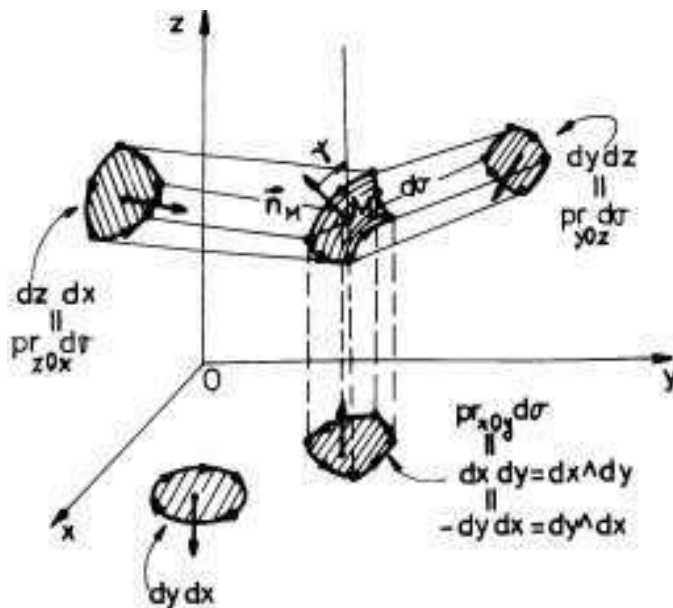

FIGURE 11

we see that the area-projection $pr_{xOy} d\sigma$ of an orientated small element $d\sigma$ (for instance the area of an (S_i)) of the surface (S) on the xOy -plane is a direct oriented area in this plane, usually denoted by $dx \, dy$. It is clear enough that the order dx then dy in the symbol $dx \, dy$ is essential, because it reflects the direct orientation "from x to y " in the xOy -plane. Hence $dx \, dy = -dy \, dx$ ($dx \, dy$ is the "up" area and $dy \, dx$ is the "down"

area-see the arrows in Fig.11). For instance, $pr_{zOy}d\sigma = dzdy$, because the orientation of the boundary of this projection is "from z to y " (see Fig.11). Since the area-projections $dx dy \approx \cos \gamma d\sigma$, $dy dz \approx \cos \alpha d\sigma$ and $dz dx \approx \cos \beta d\sigma$ (see also remark 36), from formula (3.7) (taking again Riemann sums, etc. ... do it!), we get:

$$(3.8) \quad \oint_{(S)} \oint \vec{F} \cdot \vec{n} d\sigma = \oint_{(S)} \oint P dy dz + Q dz dx + R dx dy,$$

this last being a formal expression, not used in practice. The expression $\omega = P dy dz + Q dz dx + R dx dy$ is said to be a differential form of order 2 in three variables. Do not forget the order: $dz dx$ and not $dx dz$!

EXAMPLE 100. Let us compute $I = \oint_{(S)} \oint x dy dz + y dz dx$, where (S) is the interior face of the paraboloid: $z = x^2 + y^2$, $0 \leq z \leq 4$ (see Fig.12).

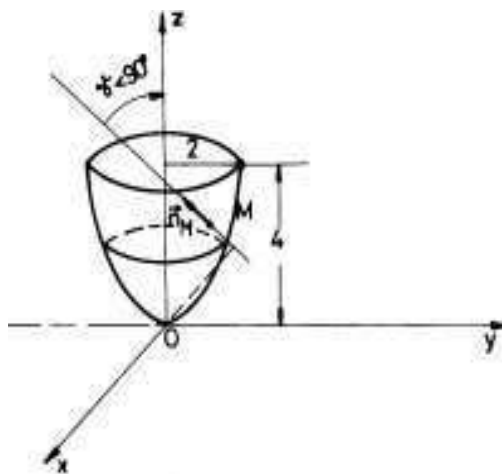

FIGURE 12

In this case $P(x, y, z) = x$, $Q(x, y, z) = y$ and $R(x, y, z) = 0$, i.e. $\vec{F} = (x, y, 0)$. Since the surface has an explicit parametrization w.r.t. z :

$$\begin{cases} x = x \\ y = y \\ z = x^2 + y^2 \end{cases}, x^2 + y^2 \leq 4,$$

we can use formula (3.2) and find $A = -\frac{\partial z}{\partial x} = -2x$, $B = -\frac{\partial z}{\partial y} = -2y$, $C = 1$, $\gamma \in [0, \frac{\pi}{2}]$,

$$\vec{n}(x, y, z) = \left(\frac{-2x}{\sqrt{1+4x^2+4y^2}}, \frac{-2y}{\sqrt{1+4x^2+4y^2}}, \frac{1}{\sqrt{1+4x^2+4y^2}} \right).$$

Let us use now the basic formula (3.6):

$$\begin{aligned} \oint_{(S)} xdydz + ydzdx &= -2 \int_{D: x^2+y^2 \leq 4} \int (x^2 + y^2) dx dy = \\ &= -2 \int_0^2 \rho^3 \left(\int_0^{2\pi} d\theta \right) d\rho = -4\pi \int_0^2 \rho^3 d\rho = -16\pi. \end{aligned}$$

REMARK 35. If (S) is not of class C^1 but it is piecewisely of class C^1 (see Fig.13), then we give an orientation to each smooth pieces of (S) such that on the common intersection curves, these last curves must have 2 distinct type of orientation (each of them coming from the orientation of the neighboring subdomains). In fact, the orientation of $\partial(S)$ completely determines the orientation of all the component subdomains.

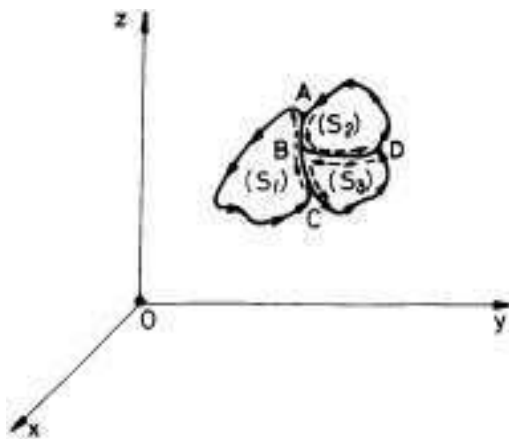

FIGURE 13

EXAMPLE 101. Let us compute the flux of the field $\vec{F} = (0, 0, z)$ on the exterior faces of the tetrahedron $[OABC]$ of Fig.14. Since the surface is a union of 4 distinct surfaces with different parametrizations,

we successively compute:

$$I_4 = \oint\oint_{[ABC]} (0, 0, z) \cdot \vec{n}_4 d\sigma.$$

Since

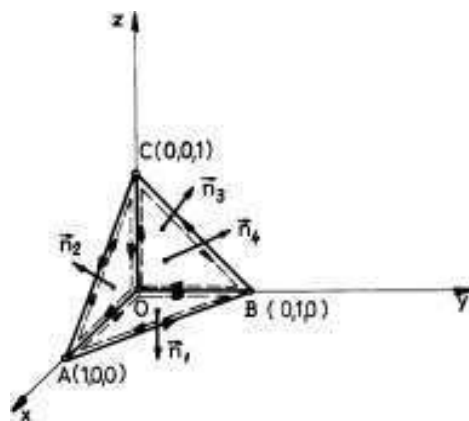

FIGURE 14

$$[ABC] : \begin{cases} x = x \\ y = y \\ z = 1 - x - y \end{cases}, x + y \leq 1,$$

$A = 1, B = 1, C = 1$, so

$$I_0 = \int\int_{x+y \leq 1} (1 - x - y) dx dy = \int_0^1 \left(\int_0^{1-x} (1 - x - y) dy \right) dx =$$

$$\int_0^1 \left(y - xy - \frac{y^2}{2} \right) \Big|_0^{1-x} dx = \int_0^1 \left(\frac{x^2}{2} - x + \frac{1}{2} \right) dx = \frac{1}{6}.$$

Now

$$I_1 = \oint\oint_{[OAB]} (0, 0, z) \cdot \vec{n}_1 d\sigma = 0,$$

because $\vec{n}_1 = -\vec{k}$ and $z = 0$ on $[OAB]$.

$$I_2 = \oint\oint_{[OCA]} (0, 0, z) \cdot \vec{n}_2 d\sigma = \oint\oint_{[OCA]} (0, 0, z) \cdot (-\vec{j}) d\sigma = 0.$$

$$I_3 = \iint_{[OBC]} (0, 0, z) \cdot (-\vec{i}) d\sigma = 0.$$

Hence the flux is equal to $I_1 + I_2 + I_3 + I_4 = \frac{1}{6}$.

REMARK 36. We shall now explain why the direct oriented area of the projection $pr_{xOy}d\sigma$ of the oriented element of area $d\sigma$ on the xOy -plane can be well approximated with $\cos\gamma d\sigma$, where γ is the angle between the Oz -axis and the normal versor in a fixed point M of the small surface which has the area $d\sigma$. We just approximated an element $d\sigma$ of a surface S with the area of a small parallelogram constructed with one vertex at M and generated by the tangent vectors $\vec{r}_u(M)$ and $\vec{r}_v(M)$ (see Fig. 7). The projection of this parallelogram on the xOy -plane is in general a quadrilateral in this plane. Let us divide our parallelogram into two equal triangles. It is enough to prove that the area of the projection of a triangle on the xOy -plane is equal to the area of the initial triangle multiplied by $\cos\gamma$, where γ is the angle between the normal versor $\vec{n}(M)$ and the versor \vec{k} . It is also sufficient to consider the triangle ABC with a vertex, say A , in the xOy -plane (see Fig. 15).

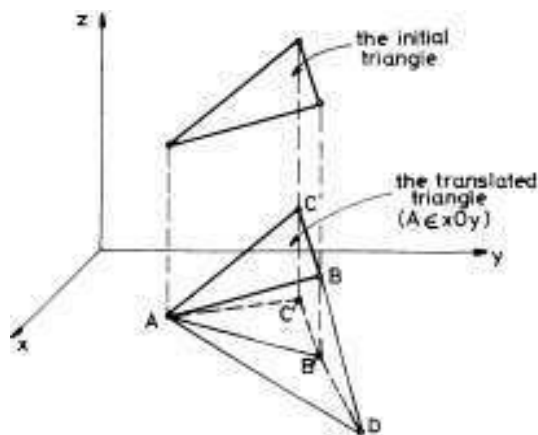

FIGURE 15

Let $D = \overline{CB} \cap (xOy\text{-plane})$. Moreover, it is sufficient to consider the initial triangle to have a entire edge, say $[AD]$, in the xOy -plane ($\text{area}(\Delta ACB) = \text{area}(\Delta ADC) - \text{area}(\Delta ABD)$).

Hence, let us take again a triangle $[XYZ]$ with $[XY] \subset xOy$ -plane (see Fig. 16). Let Z' be the projection of Z on the xOy -plane and let Z'' be the projection of Z' on $[XY]$. Since $[XY] \perp [ZZ']$ and

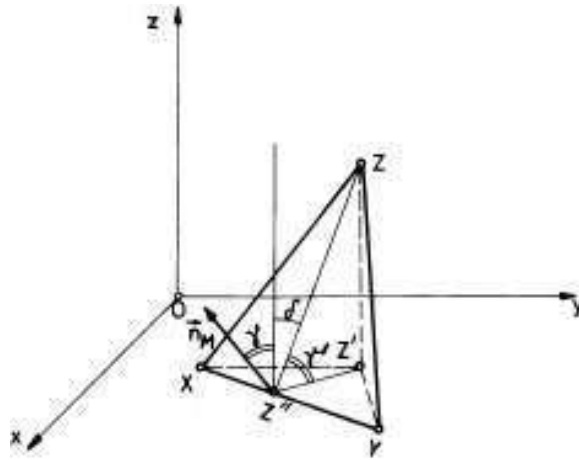

FIGURE 16

$[XY] \perp [Z'Z'']$, we see that $[XY]$ is perpendicular on the entire plane $[Z'Z'Z'']$. In particular it is perpendicular on $[ZZ'']$. Let $\vec{n}(Z'')$ be the normal versor on the plane $[XYZ]$ at the point Z'' (see Fig.16). Since $\gamma + \delta = 90^\circ$ and $\gamma' + \delta = 90^\circ$ one has that $\gamma = \gamma'$ (see Fig.16). Thus, $[Z'Z''] = [ZZ''] \cos \gamma$ and so,

$$\begin{aligned} \text{area}(\Delta XYZ) &= \frac{1}{2}[XY][ZZ''] = \frac{1}{\cos \gamma} \frac{1}{2}[XY] \cos \gamma [ZZ''] = \\ &= \frac{1}{\cos \gamma} \frac{1}{2}[XY][Z'Z''] = \frac{1}{\cos \gamma} \text{area}(\Delta XYZ'). \end{aligned}$$

Hence, $\text{area}(pr_{xOy} \Delta [XYZ]) = \text{area}(\Delta XYZ) \cos \gamma$, what we wanted to prove.

We must be very careful with the notation $dx dy$, the area of the direct oriented domain which is the projection of a small part of the direct oriented surface S , of area $d\sigma$. Since $dx dy = -dy dx$, one uses the exterior product notation $dx dy = dx \wedge dy$. To change $dx dy$ with $dy dx$ means to take the other face of the oriented projection ω (see Fig.17).

4. Problems and exercises

1. Compute $I = \iint_S xy d\sigma$, where S is the part of the plane (P) :

$2x + y + 2z = 1$ which is inside the cylinder: $x^2 + y^2 = 1$.

2. The cylindrical solid $x^2 + y^2 \leq R^2$ cut the semisphere $x^2 + y^2 + z^2 = 4R^2, z \geq 0$ into a surface S . Find its area and its centre of mass (the density function is considered to be 1).

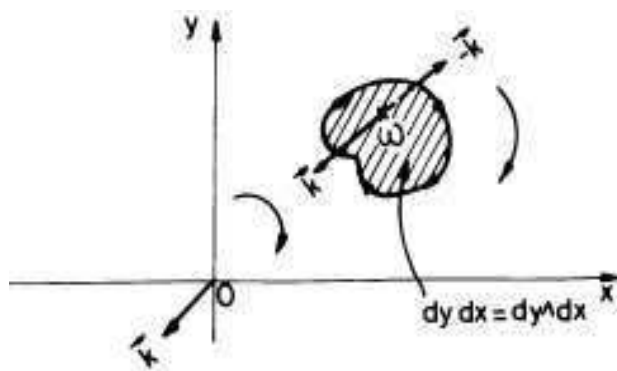

FIGURE 17

3. Compute $\iint_S (x^2 + y^2) d\sigma$ if S is a surface with the following parametrization: $x = u$, $y = v$, $z = uv$ and $u^2 + v^2 \leq 1$.
4. Find the moment of inertia of the cone $y^2 + z^2 = 4x^2$, $x \in [-2, 2]$ with respect to the Oz -axis.
5. Find the centre of mass for the 3D-lamina (S, f) , where S is the surface $x^2 + z^2 = 4y$, $y \leq 4$ and $f(x, y, z) = y$.
6. Compute $I = \iint_S (x + y + z) d\sigma$, where S is the union of all the sides of the parallelepiped $[0, 1] \times [0, 2] \times [0, 3]$.
7. Compute $I = \iint_S (x + y + z) d\sigma$, where S is the surface $x^2 + y^2 + z^2 = a^2$, $z \geq 0$.
8. Find the mass of the 3D-plate (S, f) , where S is the surface $x^2 + y^2 + z^2 = 1$, $x \geq 0$, $y \geq 0$, $z \geq 0$ and the density function is $f(x, y, z) = [x^2 + y^2 + (z - 1)^2]^{-\frac{1}{2}}$.
9. Find the area of the part of the sphere $x^2 + y^2 + z^2 = a^2$, which is inside the cylinder $x^2 + y^2 = ax$.
10. Compute $I = \oint_{(S)} xydydz + xzdzdx + 2x^2ydx dy$, where (S) is the exterior side of the surface $z = x^2 + y^2$, $x^2 + y^2 \leq 4$.
11. Compute the flux of the field $\vec{F}(x^2, y^2, z^2)$ through the interior side of the surface $x^2 + y^2 = z$, $z \leq 1$.

12. Compute the flux of the field $\vec{F}(x^3, y^3, z^3)$ through the total exterior sides of the surface $x^2 + y^2 = z^2$, $0 \leq z \leq 4$.

13. Find the flux of the field $\vec{F}(x, y, z) = x\vec{i} + y\vec{j} + z\vec{k}$ through the interior side of the sphere $x^2 + y^2 + z^2 = R^2$.

14. Find the flux of the field $\vec{F}(x^2, y^2, z^2)$ through the total exterior sides of tetrahedron $[OABC]$, where $A(1, 0, 2)$, $B(0, 2, 0)$ and $C(0, 0, 3)$.

15. Compute the flux of the field $\vec{F}\left(\frac{1}{x}, \frac{1}{y}, \frac{1}{z}\right)$ through the exterior side of the sphere $x^2 + y^2 + z^2 = R^2$.

16. Find the flux of the field $\vec{F}(yz, xz, xy)$ through the total exterior face of the cylinder $x^2 + y^2 = a^2$, $0 \leq z \leq h$.

CHAPTER 9

Gauss and Stokes formulas. Applications

1. Gauss formula (divergence theorem)

If a surface S is a union of many sides with different parametrizations, the computation of a surface integral of the second type $\oint_{(S)} \vec{F} \cdot \vec{n} d\sigma$ can be very long and not so easy. A famous formula of Gauss can reduce this computation to a calculation of a triple integral.

DEFINITION 32. We say that a surface $S = \vec{g}(D) \subset \mathbb{R}^3$ is totally closed in \mathbb{R}^3 if it is bounded, closed as a topological subset of \mathbb{R}^3 (i.e. $\mathbb{R}^3 \setminus S$ is open) and if it is the boundary $\partial\Omega$ of a bounded, closed and connected subset Ω of \mathbb{R}^3 . Moreover, S must divide the space \mathbb{R}^3 into two disjoint (with their intersection empty!) subsets, Ω and $\mathbb{R}^3 \setminus \Omega$ which each of them are connected.

For instance, any sphere is totally closed. The cylinder $x^2 + y^2 = R^2$, $0 \leq z \leq h$ is closed but not totally closed. The cone $x^2 + y^2 = z^2$, $0 \leq z \leq h$ together the disc $z = h$, $x^2 + y^2 \leq h^2$ above it is totally closed but, without that disc is closed and no totally closed. The conic surface $x^2 + y^2 = z^2$, $-3 \leq z \leq 3$, $z \notin (-\varepsilon, \varepsilon)$ with $0 < \varepsilon < 3$, together the both discs $z = 3$, $x^2 + y^2 \leq 9$ and $z = -3$, $x^2 + y^2 \leq 9$, is closed but it is not totally closed because the interior of the domain bounded by this surface is not connected (Why?).

THEOREM 95. (Gauss formula) Let $\Omega \subset \mathbb{R}^3$ be a bounded, closed and connected subset with its boundary $\partial\Omega = S$ a piecewise smooth, oriented and totally closed surface, considered with its "exterior" side (see Fig.1). Let

$$\vec{F}(x, y, z) = P(x, y, z) \vec{i} + Q(x, y, z) \vec{j} + R(x, y, z) \vec{k}$$

be a field defined on Ω , which is continuous and piecewise of class C^1 (the set of points at which this property to be of class C^1 fails is a finite

union of points, smooth lines, or smooth surfaces of zero volume). Then

$$(1.1) \quad \oint_{(S)=\partial\Omega} \vec{F} \cdot \vec{n} \, d\sigma = \iiint_{\Omega} \operatorname{div} \vec{F} \, dx \, dy \, dz,$$

where $\operatorname{div} \vec{F}(x, y, z) = \frac{\partial P}{\partial x}(x, y, z) + \frac{\partial Q}{\partial y}(x, y, z) + \frac{\partial R}{\partial z}(x, y, z)$ is called the divergence of \vec{F} .

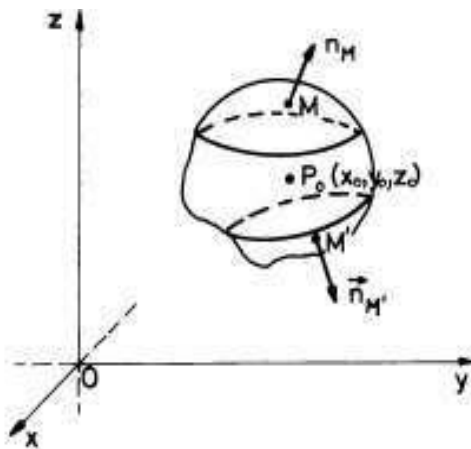

FIGURE 1

Before to prove this basic result, let us make some commentaries on it.

The philosophical importance of Gauss formula (1.1) is the following. On the left side of this formula we have an "oriented" object, in general very complicated, but only a 2D-object. On the right side one has a triple integral, a simpler object (because it has no "orientation" at all), but a 3D-object. Hence this formula connects a 2D-computation with a 3D-computation. On the left side of this formula we have in fact the flux $\Phi_S(\vec{F})$ of the field \vec{F} through the surface S , "from inside to outside", i.e. the normal versor at a point $M \in S$ is "above" the tangent plane at M to S (see Fig.1). On the right side of the formula one has "the global productivity" of the volume Ω w.r.t. the field \vec{F} . Let us explain in the following the word "productivity". Let us apply the mean formula (see theorem 87, e)) to the triple integral from the right side:

$$\iiint_{\Omega} \operatorname{div} \vec{F} \, dx \, dy \, dz = \operatorname{div} \vec{F}(P_0) \cdot \operatorname{vol}(\Omega),$$

where P_0 is a point inside Ω . Thus, Gauss formula says that:

$$\operatorname{div} \vec{F}(P_0) = \frac{\Phi_{S=\partial\Omega}(\vec{F})}{\operatorname{vol}(\Omega)},$$

i.e. if $\operatorname{diam}(\Omega)$ is very small, the "productivity" $\operatorname{div} \vec{F}(P_0)$ at P_0 measures how much energy created by the field \vec{F} inside Ω is transferred from inside of Ω to outside. More exactly, it is equal to the quantity of flux produced per unity of volume. This is the true interpretation of the divergence of \vec{F} , defined above. For instance, if one has no "production" ($\operatorname{div} \vec{F} = 0$) inside Ω , one has no flux of \vec{F} through $S = \partial\Omega$. Gauss formula explains many phenomena in Physics, Chemistry, Economy, Engineering, etc.

Gauss formula or the divergence theorem was obtained by Gauss during the examination of the electric fields, magnetic fields or gravitational fields. Let say some words on the Gauss law in Physics. Let q_0 be a fixed point positive electric charge in the origin O and let $M(x, y, z)$ be an arbitrary point in space. Let $\vec{r} = \vec{OM} = x\vec{i} + y\vec{j} + z\vec{k}$ be the position vector of M . We always assume that at M we have another free point positive electric charge $q = 1C$ (Coulomb). Then the famous Coulomb law says that the repulsive electric field at $M(x, y, z)$ is:

$$\vec{E}(x, y, z) = \frac{q_0}{4\pi\epsilon_0} \cdot \frac{\vec{r}}{r^3},$$

where $r = (x^2 + y^2 + z^2)^{\frac{1}{2}}$ and ϵ_0 is the electric constant, depending only on the electric properties of the space itself. The Gauss law says that if S is any closed continuous surface which contains the origin (i.e. the electric charge q_0), then the flux $\Phi_S(\vec{E})$ of the electric field through S , from inside to outside (the force is a repulsive one!) is constant, namely it always is equal to $\frac{q_0}{\epsilon_0}$. This means that:

$$(1.2) \quad \oint_S \vec{E} \cdot \vec{n} d\sigma = \frac{q_0}{\epsilon_0}.$$

Gauss succeeded to express this last law as a "local law" (at a point $P_0 \neq O$):

$$(1.3) \quad \operatorname{div} \vec{E}(P_0) = \frac{\rho(P_0)}{\epsilon_0},$$

where $\rho(P_0)$ is the charge density at P_0 produced by q_0 . It appears that from here we can deduce our Gauss formula (1.1) in this particular case. There is a mathematical problem! The electric field is not defined at the origin O ! Thus, our Gauss formula (1.1) cannot be applied in this

case. But, in higher mathematics one can extend Gauss formula to such more complicated situation and one can obtain the Gauss law of Physics as a particular case of it. In fact, Gauss law is equivalent to Coulomb law (see [BPC]). Since $\iiint_{\Omega} \rho(P) dx dy dz = q_0$, the formulas

(1.2) and (1.3) give rise to the equality:

$$(1.4) \quad \oint_{(S)=\partial\Omega} \vec{E} \cdot \vec{n} d\sigma = \iiint_{\Omega} \operatorname{div} \vec{E} dx dy dz,$$

i.e. Gauss formula for the electric field \vec{E} . But, what is the meaning of the triple integral on the right, because the electric field \vec{E} is not defined at O ? This is a big mathematical problem which forced scientists to create new concepts and notions like distributions, potential theory, etc. We shall only compute the surface integral of the second type of formula (1.4), i.e. the flux of \vec{E} through the surface of a sphere of radius $R > 0$:

$$\begin{aligned} \oint_{(S): x^2+y^2+z^2=R^2} \vec{E} \cdot \vec{n} d\sigma &= \frac{q_0}{4\pi\epsilon_0} \oint_{(S): x^2+y^2+z^2=R^2} \frac{\vec{r}}{r^3} \cdot \vec{n} d\sigma = \\ &= \frac{q_0}{4\pi\epsilon_0} \oint_{(S): x^2+y^2+z^2=R^2} \frac{1}{R^2} \vec{n} \cdot \vec{n} d\sigma = \frac{q_0}{\epsilon_0}, \end{aligned}$$

because $\frac{\vec{r}}{r} = \vec{n}$ and $\oint_{(S): x^2+y^2+z^2=R^2} d\sigma = 4\pi R^2$ (the area of the sphere

of radius R) in this particular case. Hence,

$$\oint_{(S): x^2+y^2+z^2=R^2} \vec{E} \cdot \vec{n} d\sigma = \frac{q_0}{\epsilon_0}.$$

Gauss observed that the flux of \vec{E} does not depend on the radius of the sphere, so that he tried to prove that the sphere can be substituted with an arbitrary closed surface S , which contains O as an interior point of it. The reader can find a proof of this last statement in any advanced course on Electricity, for instance in [BPC].

Now we prove the main theorem 95.

PROOF. (for Gauss formula) We assume that our domain Ω can be decomposed into a finite number of simple subdomains Ω_i of the same type like Ω such that for $i \neq j$, $\Omega_i \cap \Omega_j$ is at most a surface of

volume zero. A simple subdomain is a simple domain w.r.t. one of the axes Ox , Oy , or Oz . Let us assume that we have proved the theorem for simple domains and let us consider a nonsimple domain like in Fig.2. In this case $\Omega = \Omega_1 \cup \Omega_2 \cup \Omega_3$ and let $(S_1) = \Omega_1 \cap \Omega_2$, $(S_2) = \Omega_1 \cap \Omega_3$. Since the normal versors \vec{n}_1, \vec{n}_2 on (S_1) and \vec{n}_1', \vec{n}_3 on (S_2) respectively, have opposite signs, the corresponding surface integrals annihilate one to each other (see Fig.2).

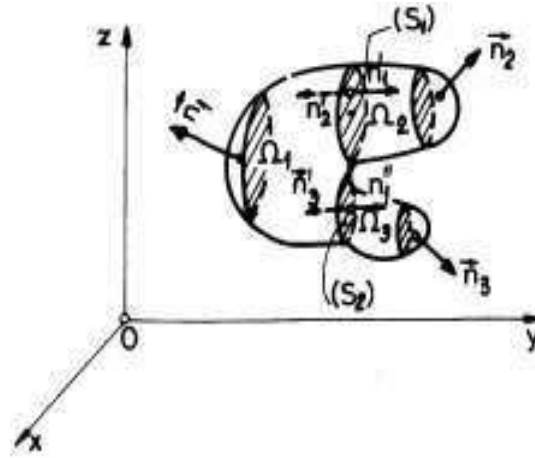

FIGURE 2

The triple integral can be naturally decomposed into three triple integrals and so we can apply Gauss formula for the three simple domains:

$$\begin{aligned} \iiint_{\Omega} \operatorname{div} \vec{F} dx dy dz &= \left[\iiint_{\Omega_1} \operatorname{div} \vec{F} dx dy dz \right] + \left[\iiint_{\Omega_2} \operatorname{div} \vec{F} dx dy dz \right] + \\ &+ \left[\iiint_{\Omega_3} \operatorname{div} \vec{F} dx dy dz \right] = \\ &= \left[\iint_{(S) \setminus (\partial\Omega_2) \setminus (\partial\Omega_3)} \vec{F} \cdot \vec{n}_1 d\sigma + \iint_{(S_1)} \vec{F} \cdot \vec{n}_1 d\sigma + \iint_{(S_2)} \vec{F} \cdot \vec{n}_1' d\sigma \right] + \\ &+ \left[\iint_{(\partial\Omega_2) \setminus (S_1)} \vec{F} \cdot \vec{n}_2 d\sigma + \iint_{(S_1)} \vec{F} \cdot \vec{n}_2 d\sigma \right] + \end{aligned}$$

$$\begin{aligned}
& + \left[\iint_{(\partial\Omega_3)\setminus(S_2)} \vec{F} \cdot \vec{n}_3 d\sigma + \iint_{(S_2)} \vec{F} \cdot \vec{n}'_3 d\sigma \right] = \\
& = \left[\iint_{(S)\setminus(\partial\Omega_2)\setminus(\partial\Omega_3)} \vec{F} \cdot \vec{n}_1 d\sigma + \iint_{(\partial\Omega_2)\setminus(S_1)} \vec{F} \cdot \vec{n}_2 d\sigma + \iint_{(\partial\Omega_3)\setminus(S_2)} \vec{F} \cdot \vec{n}_3 d\sigma \right] + \\
& + \left[\iint_{(S_1)} \vec{F} \cdot \vec{n}'_1 d\sigma - \iint_{(S_1)} \vec{F} \cdot \vec{n}_1 d\sigma \right] + \left[\iint_{(S_2)} \vec{F} \cdot \vec{n}'_2 d\sigma - \iint_{(S_2)} \vec{F} \cdot \vec{n}_2 d\sigma \right] = \\
& = \iint_{(S)} \vec{F} \cdot \vec{n} d\sigma.
\end{aligned}$$

We see that it is sufficient to separately prove the following three equalities (then add them!):

$$(1.5) \quad a) \iint_{(S)} P(x, y, z) dydz = \iiint_{\Omega} \frac{\partial P}{\partial x} dx dy dz,$$

$$(1.6) \quad b) \iint_{(S)} Q(x, y, z) dz dx = \iiint_{\Omega} \frac{\partial Q}{\partial y} dx dy dz,$$

$$(1.7) \quad c) \iint_{(S)} R(x, y, z) dx dy = \iiint_{\Omega} \frac{\partial R}{\partial z} dx dy dz.$$

Since the proofs for all these formulae *a*), *b*) or *c*) are similar, we shall prove only formula *c*). For this, after dividing the domain Ω into a finite union of nonoverlapping subdomains (see what we did above!) which are simple w.r.t. Oz -axis, we suppose that Ω is a simple domain w.r.t. Oz -axis like in Fig.3. This means that

$$\Omega = \{(x, y, z) : \varphi(x, y) \leq z \leq \psi(x, y), (x, y) \in \Omega_{xy} = pr_{xOy}\Omega\},$$

where φ and ψ are continuous functions defined on Ω_{xy} .

Let us look now at Fig.3 and write:

$$\iiint_{\Omega} \frac{\partial R}{\partial z} dx dy dz = \iint_{\Omega_{xy}} \left(\int_{\varphi(x,y)}^{\psi(x,y)} \frac{\partial R}{\partial z} dz \right) dx dy =$$

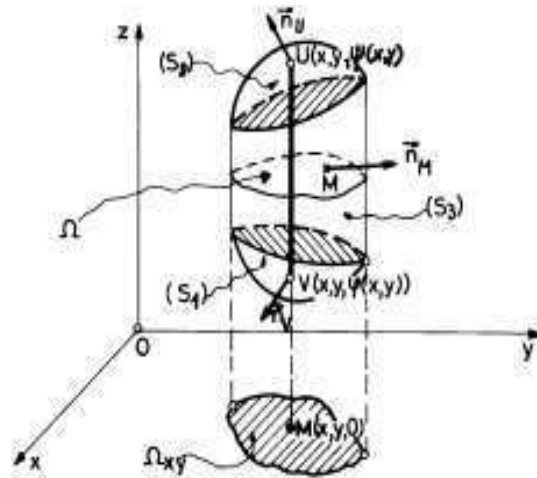

FIGURE 3

$$\begin{aligned}
 &= \iint_{\Omega_{xy}} R(x, y, \psi(x, y)) dx dy - \iint_{\Omega_{xy}} R(x, y, \varphi(x, y)) dx dy = \\
 &= \oint_{(S_2)} \oint R(x, y, z) dx dy + \oint_{(S_1)} \oint R(x, y, z) dx dy + \\
 &+ \oint_{(S_3)} \oint R(x, y, z) dx dy = \oint_{(S)} \oint R(x, y, z) dx dy,
 \end{aligned}$$

because $\oint_{(S_3)} \oint R(x, y, z) dx dy = 0$, ($\gamma = 90^\circ$, so $\cos \gamma = 0$ and $dx dy =$

$\cos \gamma d\sigma = 0$ for (S_3)).

For proving (b) for instance, we eventually decompose this last Ω (which was considered to be simple w.r.t. Oz -axis) more, up to we get it as a finite union of simple subdomains w.r.t. Oy -axis. \square

EXAMPLE 102. Let us use Gauss formula to compute the flux $\Phi_S(\vec{F})$ of the field $\vec{F} = x^2 \vec{i} + y^2 \vec{j} + z^2 \vec{k}$ through the total exterior sides surface S of the cube $\Omega = [0, 1] \times [0, 1] \times [0, 1]$ (see Fig.4).

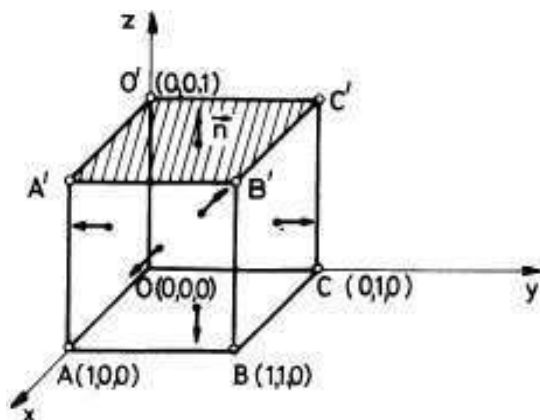

FIGURE 4

Use then this result to compute the flux Φ_1 of the same field \vec{F} through the exterior surface of the cube, except the hatched face $[O'A'B'C']$.

$$\begin{aligned}
 \Phi_S(\vec{F}) &= \oint_S \vec{F} \cdot \vec{n} \, d\sigma \stackrel{\text{Gauss}}{=} \iiint_{\Omega} (2x + 2y + 2z) \, dx \, dy \, dz = \\
 &= 2 \int_0^1 \left(\int_0^1 \left(\int_0^1 (x + y + z) \, dx \right) dy \right) dz = \\
 &= 2 \int_0^1 \left(\int_0^1 \left(\left(\frac{x^2}{2} + xy + xz \right) \Big|_0^1 \right) dy \right) dz = \\
 &= 2 \int_0^1 \left(\int_0^1 \left(\frac{1}{2} + y + z \right) dy \right) dz = 2 \int_0^1 \left(\left(\frac{y}{2} + \frac{y^2}{2} + yz \right) \Big|_0^1 \right) dz = \\
 &= 2 \int_0^1 (1 + z) \, dz = 2 \left(z + \frac{z^2}{2} \right) \Big|_0^1 = 3.
 \end{aligned}$$

Let (S_1) be the hatched surface $[O'A'B'C']$. Since the normal versor $\vec{n} = \vec{k} = (0, 0, 1)$, one has that $dydz = \cos \alpha d\sigma = 0$ and $dzdx = \cos \beta d\sigma = 0$. Thus,

$$\Phi_{(S_1)}(\vec{F}) = \int_{[0,1] \times [0,1]} dx \, dy = 1.$$

Hence $\Phi_1 = \Phi_S(\vec{F}) - \Phi_{(S_1)}(\vec{F}) = 2$.

EXAMPLE 103. Compute the flux of the vector field $\vec{F} = (x^2, y^2, z)$ through the sphere $x^2 + y^2 + z^2 = 1$, from exterior to interior (see Fig. 5).

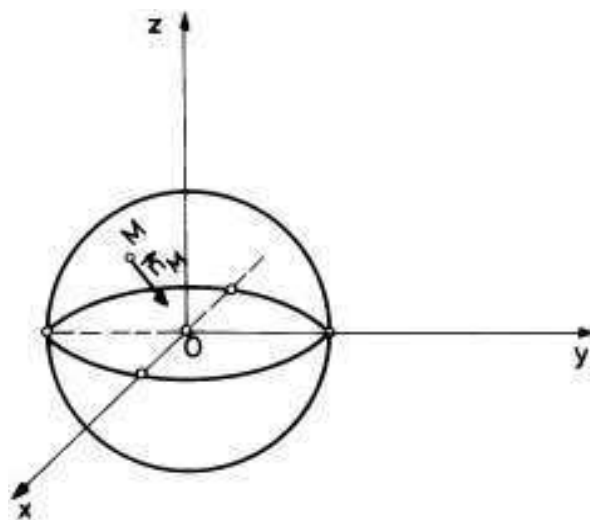

FIGURE 5

We simply apply Gauss formula (95):

$$\Phi_{(S)}(\vec{F}) = - \iiint_{x^2+y^2+z^2 \leq 1} (2x + 2y + 1) dx dy dz.$$

Let us use spherical coordinates to compute the last triple integral:

$$\begin{aligned} & - \iiint_{x^2+y^2+z^2 \leq 1} (2x + 2y + 1) dx dy dz = \\ & = - \int_0^1 \rho^2 \left(\int_0^{2\pi} \left(\int_0^\pi (2\rho \cos \varphi \sin \theta + 2\rho \sin \varphi \sin \theta + 1) \sin \theta d\theta \right) d\varphi \right) d\rho = \\ & = -2 \int_0^1 \rho^3 \left(\int_0^{2\pi} (\cos \varphi + \sin \varphi) \left(\int_0^\pi \sin^2 \theta d\theta \right) d\varphi \right) d\rho - \\ & - \int_0^1 \rho^2 \left(\int_0^{2\pi} \left(\int_0^\pi \sin \theta d\theta \right) d\varphi \right) d\rho = 0 - 2\pi \cdot 2 \cdot \frac{\rho^3}{3} \Big|_0^1 = -\frac{4\pi}{3}. \end{aligned}$$

2. A mathematical model of the heat flow in a solid

Let Ω be a bounded, closed and homogenous 3D-solid and let (S) be its boundary which is supposed to be a piecewise smooth, connected and totally closed surface. The heat will flow in the direction of a low temperature. We assume that the rate of flow is proportional to the gradient of temperature. Let \vec{v} be the velocity of the heat flow and let $u(x, y, z, t)$ be the temperature at the point M of coordinates x, y , and z at the moment t . Then

$$(2.1) \quad \vec{v} = -K \overrightarrow{\text{grad } u},$$

where K is the *thermal conductivity* (a constant) and the gradient is referred to x, y and z . The amount of heat leaving Ω through (S) , "from interior to exterior", is given by the flux

$$\Phi_{(S)}(\vec{v}) = \oint_{(S)} \vec{v} \cdot \vec{n} \, d\sigma.$$

Let us use now Gauss formula to compute this flux:

$$\oint_{(S)} \vec{v} \cdot \vec{n} \, d\sigma = -K \iiint_{\Omega} \text{div}(\overrightarrow{\text{grad } u}) \, dx \, dy \, dz = -K \iiint_{\Omega} \Delta u \, dx \, dy \, dz,$$

where $\Delta u = \frac{\partial^2 u}{\partial x^2} + \frac{\partial^2 u}{\partial y^2} + \frac{\partial^2 u}{\partial z^2}$. The total amount of heat H in Ω is:

$$H = \iiint_{\Omega} \sigma \rho u \, dx \, dy \, dz,$$

where σ is the specific heat of the material of the solid (a constant) and ρ is the density of Ω . Thus, the time rate of decrease of H is:

$$-\frac{\partial H}{\partial t} = -\iiint_{\Omega} \sigma \rho \frac{\partial u}{\partial t} \, dx \, dy \, dz.$$

Since this last one must equal the amount of heat leaving Ω , one has:

$$-\iiint_{\Omega} \sigma \rho \frac{\partial u}{\partial t} \, dx \, dy \, dz = -K \iiint_{\Omega} \Delta u \, dx \, dy \, dz,$$

or

$$\iiint_{\Omega} \left(\sigma \rho \frac{\partial u}{\partial t} - K \Delta u \right) \, dx \, dy \, dz = 0.$$

Since the integrand function is continuous w.r.t. x, y and z , since Ω was arbitrarily chosen, by a local application of the mean formula, we

see that $\sigma\rho\frac{\partial u}{\partial t} - K\Delta u$ is identical to zero on Ω (prove this in general like in the case of a simple integral!). Finally we get the famous parabolic PDE (partial differential equation) of the heat flow:

$$\frac{\partial u}{\partial t} = c^2\Delta u,$$

where $c^2 = \frac{K}{\sigma\rho}$. If for a small interval of time the heat flow does not depend on time, we get $\Delta u = 0$, which is called the *Laplace equation*. It is fundamental in many branches of Applied Mathematics. More discussions on this subject can be find in any course of PDE.

3. Stokes Theorem

This fundamental result is a generalization of the Green theorem (in plane), for the 3-dimensional case. This theorem says that in some conditions a surface integral of the second type can be transformed into a line integral and conversely.

A surface $(S) \subset \mathbb{R}^3$ has the curve Γ as its *boundary* or *border* if $\Gamma \subset (S)$, Γ is a piecewise smooth, connected and "closed" curve ($\vec{r}(a) = \vec{r}(b)$, $\vec{r} : [a, b] \rightarrow \Gamma \subset \mathbb{R}^3$) and, for any point M_0 of Γ , there exists a small $\delta > 0$ such that the intersection $B(M_0; r) \cap (S)$, $0 < r \leq \delta$, between any ball (in \mathbb{R}^3) with centre at M_0 and radius r , at most δ , has the property that $B(M_0; r) \setminus [B(M_0; r) \cap (S)]$ is a connected set. Moreover, if $M_0 \in (S)$ but $M_0 \notin \Gamma$, then there exists at least one ball $B(M_0; r)$, $r > 0$ such that $B(M_0; r) \setminus [B(M_0; r) \cap (S)]$ is the disjoint union of two connected subsets of $B(M_0; r)$ (their intersections is empty!).

A sphere S is not a surface with a border. But a semisphere is a surface with a border Γ , the unique "big" circle on the sphere. Other examples of surfaces with a border one can see in Fig.6, Fig.7 or Fig.8. We must be careful! For instance, the cylinder $x^2 + y^2 = R^2$, $0 \leq z \leq h$ has not a (unique) border in our acceptance because its candidate for a "border" is the nonconnected union between the following two circles: $x^2 + y^2 = R^2$, $z = 0$ and $x^2 + y^2 = R^2$, $z = h$, where $h \neq 0$. If we add to this last cylinder the "above" disc $x^2 + y^2 \leq R^2$, $z = h$, the obtained surface has a unique (connected) border: $x^2 + y^2 = R^2$, $z = 0$, thus it is a surface with a border in our previous acceptance.

Let $\vec{g} : D \rightarrow \mathbb{R}^3$, $\vec{g}(u, v) = x(u, v)\vec{i} + y(u, v)\vec{j} + z(u, v)\vec{k}$, be a piecewise smooth deformation and let $(S) = \vec{g}(D)$ be its corresponding (direct oriented) surface with a border like above.. Let $\vec{F}(x, y, z) = P(x, y, z)\vec{i} + Q(x, y, z)\vec{j} + R(x, y, z)\vec{k}$ be a field of class C^1 defined on a space domain which contains the surface (S) . Let $\partial D = \gamma$ be a direct

oriented closed piecewise smooth curve and let $\Gamma = \partial(S)$ be the border of (S) which is the image of γ through the deformation \vec{g} . Notice that Γ is "closed" and the orientation of Γ , which is that one inherited from the direct orientation of γ in the uov -plane, is compatible with the direct orientation of (S) . This means that if we walk on the border Γ in the direction indicated by its direct orientation, the direct face of the surface (S) is always "on the left" (see Fig.6). The surface (S) of Fig.6 is not simple w.r.t. Oz -axis (i.e. it has no parametrization of the form $z = z(x, y)$, $(x, y) \in pr_{xOy}(S)$), but we can divide it into two nonoverlapping oriented surfaces (S_1) and (S_2) with the corresponding borders $\partial(S_1) = [AEBCA]$ and $\partial(S_2) = [FACBF]$ respectively (see Fig.6). It will be easy to prove that if the bellow Stokes formula is true for simple surfaces (S_1) and (S_2) , then it is true for the entire $(S) = (S_1) \cup (S_2)$ (see this proof bellow!). This is why we shall prove this basic formula only for a simple surface (S) w.r.t. Oz -axis.

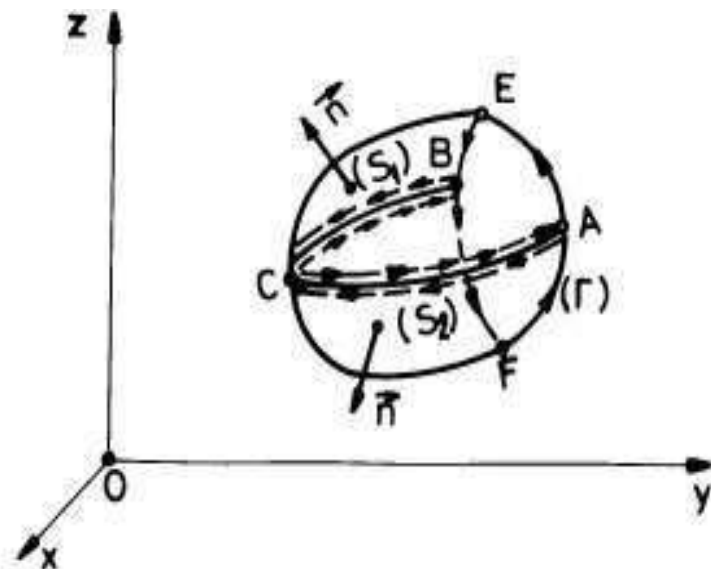

FIGURE 6

Let us recall that $\text{curl } \vec{F}$ is a new vector field associated to the field \vec{F} as follows:

$$(3.1) \quad \text{curl } \vec{F} = \det \begin{pmatrix} \vec{i} & \vec{j} & \vec{k} \\ \frac{\partial}{\partial x} & \frac{\partial}{\partial y} & \frac{\partial}{\partial z} \\ P & Q & R \end{pmatrix} =$$

$$= \left(\frac{\partial R}{\partial y} - \frac{\partial Q}{\partial z} \right) \vec{i} + \left(\frac{\partial P}{\partial z} - \frac{\partial R}{\partial x} \right) \vec{j} + \left(\frac{\partial Q}{\partial x} - \frac{\partial P}{\partial y} \right) \vec{k}.$$

Recall that the normal vector can be computed by the formula

$$\vec{n} = \left(\frac{A}{\sqrt{A^2 + B^2 + C^2}}, \frac{B}{\sqrt{A^2 + B^2 + C^2}}, \frac{C}{\sqrt{A^2 + B^2 + C^2}} \right)$$

and $d\sigma = \sqrt{A^2 + B^2 + C^2} du dv$. Let us put

$$n_x = \frac{A}{\sqrt{A^2 + B^2 + C^2}}, n_y = \frac{B}{\sqrt{A^2 + B^2 + C^2}}, n_z = \frac{C}{\sqrt{A^2 + B^2 + C^2}}.$$

THEOREM 96. (*Stokes formula*) Let D , (S) , \vec{g} , $\Gamma = \partial(S)$, etc. be the above notation and hypotheses. Then

$$(3.2) \quad \oint_{(S)} \oint (\text{curl } \vec{F}) \cdot \vec{n} d\sigma = \oint_{\Gamma} P dx + Q dy + R dz.$$

The first surface integral is the flux of the $\text{curl } \vec{F}$ through the surface (S) . The last line integral is the circulation (or the work) of \vec{F} on the oriented border Γ of (S) . Stokes formula says that this flux of $\text{curl } \vec{F}$ and the circulation of \vec{F} are equal.

PROOF. Let us put the expression of $\text{curl } \vec{F}$ from (3.1) on the left side of formula (3.2):

$$\begin{aligned} \oint_{(S)} \oint (\text{curl } \vec{F}) \cdot \vec{n} d\sigma &= \oint_{(S)} \oint \left[\left(\frac{\partial R}{\partial y} - \frac{\partial Q}{\partial z} \right) n_x + \left(\frac{\partial P}{\partial z} - \frac{\partial R}{\partial x} \right) n_y + \right. \\ &\quad \left. + \left(\frac{\partial Q}{\partial x} - \frac{\partial P}{\partial y} \right) n_z \right] d\sigma = \oint_{(S)} \oint \left(\frac{\partial P}{\partial z} n_y - \frac{\partial P}{\partial y} n_z \right) d\sigma + \\ &\quad + \oint_{(S)} \oint \left(\frac{\partial Q}{\partial x} n_z - \frac{\partial Q}{\partial z} n_x \right) d\sigma + \oint_{(S)} \oint \left(\frac{\partial R}{\partial y} n_x - \frac{\partial R}{\partial x} n_y \right) d\sigma. \end{aligned}$$

To prove that this last sum is equal to $\oint_{\Gamma} P dx + Q dy + R dz$ it is enough to prove the following three equalities:

$$\text{a) } \oint_{(S)} \oint \left(\frac{\partial P}{\partial z} n_y - \frac{\partial P}{\partial y} n_z \right) d\sigma = \oint_{\Gamma} P dx,$$

$$\begin{aligned} \text{b) } \iint_{(S)} \oint_{\Gamma} \left(\frac{\partial Q}{\partial x} n_z - \frac{\partial Q}{\partial z} n_x \right) d\sigma &= \oint_{\Gamma} Q dy, \\ \text{c) } \iint_{(S)} \oint_{\Gamma} \left(\frac{\partial R}{\partial y} n_x - \frac{\partial R}{\partial x} n_y \right) d\sigma &= \oint_{\Gamma} R dz. \end{aligned}$$

Since the proof of each of these equalities are similar, we shall prove only a). Now we can suppose that (S) is simple w.r.t. Oz -axis (otherwise we decompose it into a finite simple surfaces like in Fig.6). Hence, one can find for (S) an explicit parametrization w.r.t. z :

$$(S) : \begin{cases} x = x \\ y = y \\ z = z(x, y) \end{cases}, (x, y) \in \Omega_{xy} = pr_{xOy}(S)$$

(see Fig.7). In this situation

$$\vec{n} = \frac{\left(-\frac{\partial z}{\partial x}, -\frac{\partial z}{\partial y}, 1 \right)}{\sqrt{\left(\frac{\partial z}{\partial x} \right)^2 + \left(\frac{\partial z}{\partial y} \right)^2 + 1}}$$

and the left side of a) becomes:

$$\begin{aligned} & \iint_{(S)} \oint_{\Gamma} \left(\frac{\partial P}{\partial z} n_y - \frac{\partial P}{\partial y} n_z \right) d\sigma = \\ &= \iint_{\Omega_{xy}} \left[-\frac{\partial P}{\partial z}(x, y, z(x, y)) \cdot \frac{\partial z}{\partial y} - \frac{\partial P}{\partial y}(x, y, z(x, y)) \right] dx dy = \\ &= \iint_{\Omega_{xy}} -\frac{\partial}{\partial y} [P(x, y, z(x, y))] dx dy = \\ & \stackrel{Green}{=} \oint_{\gamma} P(x, y, z(x, y)) dx = \oint_{\Gamma} P(x, y, z) dx, \end{aligned}$$

i.e. the right side of a). Here we just applied Green formula for the domain Ω_{xy} with its boundary γ (see Fig.7).

If (S) is not simple with respect to Oz -axis we reduce everything to simple components of (S) . 'Let us apply this last idea for the surface

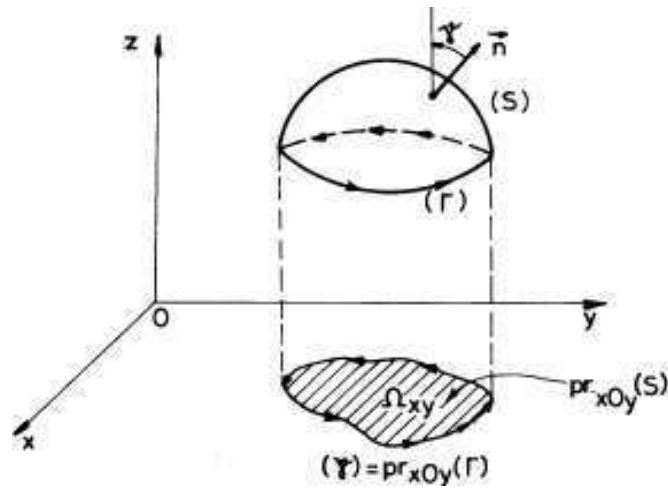

FIGURE 7

of Fig.6.

$$\begin{aligned} \iint_{(S)} (\text{curl } \vec{F}) \cdot \vec{n} \, d\sigma &= \left[\iint_{(S_1)} (\text{curl } \vec{F}) \cdot \vec{n} \, d\sigma \right] + \left[\iint_{(S_2)} (\text{curl } \vec{F}) \cdot \vec{n} \, d\sigma \right] = \\ & \left[\oint_{[AEB]} Pdx + Qdy + Rdz + \oint_{[BCA]} Pdx + Qdy + Rdz \right] + \\ & + \left[\oint_{[BFA]} Pdx + Qdy + Rdz + \oint_{[ACB]} Pdx + Qdy + Rdz \right]. \end{aligned}$$

But

$$\oint_{[BCA]} Pdx + Qdy + Rdz = - \oint_{[ACB]} Pdx + Qdy + Rdz,$$

so that

$$\begin{aligned} \iint_{(S)} (\text{curl } \vec{F}) \cdot \vec{n} \, d\sigma &= \oint_{[AEB]} Pdx + Qdy + Rdz + \\ & + \oint_{[BFA]} Pdx + Qdy + Rdz = \oint_{\Gamma} Pdx + Qdy + Rdz. \end{aligned}$$

□

EXAMPLE 104. Let us compute the line integral $I = \oint_{\Gamma} x^2 y dx + y^2 dy + z^2 dz$, where Γ is the oriented curve $[O'A'B'C'O']$ from Fig.8. For this, let us consider the oriented surface

$$(S) : \begin{cases} x = x \\ y = y \\ z = 1 \end{cases}, (x, y) \in [0, 1] \times [0, 1],$$

which has as its (unique) border the connected curve Γ . Since

$$\operatorname{curl} \vec{F} = \det \begin{pmatrix} \vec{i} & \vec{j} & \vec{k} \\ \frac{\partial}{\partial x} & \frac{\partial}{\partial y} & \frac{\partial}{\partial z} \\ x^2 y & y^2 & z^2 \end{pmatrix} = -x^2 \vec{k},$$

we can apply Stokes formula (3.2) and find:

$$\begin{aligned} \oint_{\Gamma} x^2 y dx + y^2 dy + z^2 dz &= \oint \oint_{(S)} (\operatorname{curl} \vec{F}) \cdot \vec{n} d\sigma = - \int \int_{[0,1] \times [0,1]} x^2 dx dy = \\ &= - \int_0^1 x^2 \left(\int_0^1 dy \right) dx = - \int_0^1 x^2 dx = -\frac{1}{3}. \end{aligned}$$

The same curve Γ with the inverse orientation is also the border of the surface S' obtained by the union of the five other sides of the cube, except the "above" side, situated on the plane $z = 1$. This surface is oriented by the exterior normal vectors like in Fig.8.

Hence, $\oint \oint_{S'} (\operatorname{curl} \vec{F}) \cdot \vec{n} d\sigma = \frac{1}{3}$. Let us now directly compute the line integral I .

$$\begin{aligned} I = \oint_{\Gamma} x^2 y dx + y^2 dy + z^2 dz &= \oint_{[O'A'] : x=x, y=0, z=1, x \in [0,1]} x^2 y dx + y^2 dy + z^2 dz + \\ &+ \oint_{[A'B'] : x=1, y=y, z=1, y \in [0,1]} x^2 y dx + y^2 dy + z^2 dz + \\ &+ \oint_{[B'C'] : x=x, y=1, z=1, x \in [0,1]} x^2 y dx + y^2 dy + z^2 dz + \end{aligned}$$

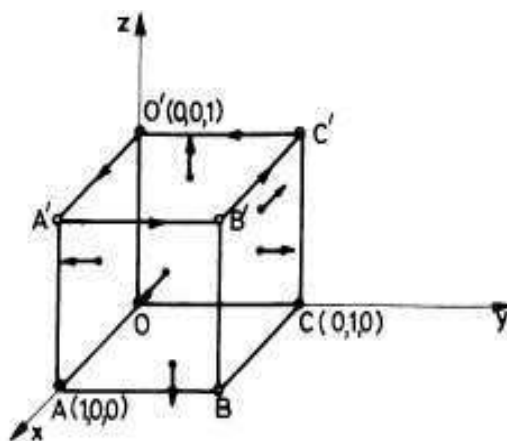

FIGURE 8

$$\begin{aligned}
 &+ \oint_{[C'O']:x=0,y=y,z=1,y \in [0,1]} x^2 y dx + y^2 dy + z^2 dz = \\
 &= 0 + \int_0^1 y^2 dy - \int_0^1 x^2 dx - \int_0^1 y^2 dy = -\frac{1}{3}.
 \end{aligned}$$

We just obtained the same result like that one obtained by using Stokes formula. Hence, these last computation can also be viewed as a simple verification.

We know that if $\vec{F} : D \rightarrow \mathbb{R}^3$ is a conservative field of class C^1 on a domain D , then $\text{curl } \vec{F} = \vec{0}$ (see theorem 68). Conversely, if D is a simply connected domain (any totally closed surface $S \subset D$ can be continuously shrunk to a point in D), then the field \vec{F} of class C^1 is conservative. We easily see that in order to prove that \vec{F} is conservative, it is enough to prove that the line integral $\oint_{\gamma} \vec{F} \cdot d\vec{r} = 0$ on any

"closed" piecewise smooth curve $\gamma \subset D$ (construct a primitive for \vec{F} of the type: $U(x, y, z) = \int_{(a,b,c)}^{(x,y,z)} \vec{F} \cdot d\vec{r}$). Now, for any "closed" piecewise

smooth curve $\gamma \subset D$, it is intuitively clear (at least for the usual balls, cylindrical domains, conical domains, paraboloidal domains, etc.) that there exists a bounded, connected piecewise smooth surface $T \subset D$

with the unique border γ (try to explain this existence at least for a starred domain D , i.e. if there exists a point $P_0 \in D$ such that if P is another point in D , then the whole segment $[P_0P]$ is included in D). Then we can apply Stokes formula for the surface T with its border γ :

$$\oint_T \oint (\text{curl } \vec{F}) \cdot \vec{n} d\sigma = \oint_{\gamma} Pdx + Qdy + Rdz.$$

But $\text{curl } \vec{F} = \vec{0}$, thus $\oint_{\gamma} Pdx + Qdy + Rdz = 0$. Hence \vec{F} is conservative.

Sometimes Stokes formula cannot be easily applied, but this last result can work easily.

EXAMPLE 105. Let us compute the line integral $I = \oint_{\Gamma} x^2 dx + y^2 dy + z^2 dz$, where Γ this time is the oriented curve $[ABCD]$ of Fig.9.

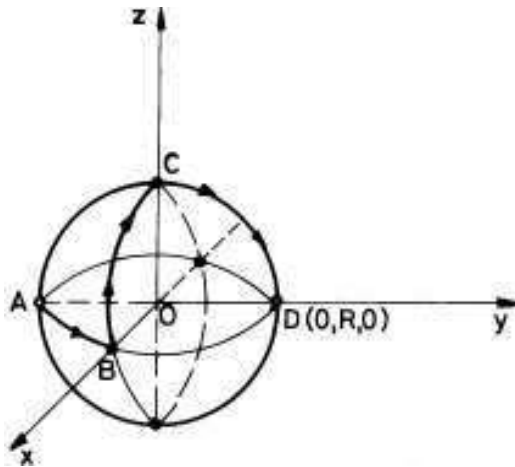

FIGURE 9

Since $\vec{F} = (x^2, y^2, z^2)$, $\text{curl } \vec{F} = \vec{0}$ and this implies that \vec{F} is conservative. Hence, the integral $\oint_{\Gamma} x^2 dx + y^2 dy + z^2 dz$ does not depend on the integration path which connects the points A and D. The simplest path which connect A and D is the oriented segment $[AD] : x = 0$,

$y = y, z = 0$. Thus,

$$\oint_{\Gamma} x^2 dx + y^2 dy + z^2 dz = \int_{-R}^R y^2 dy = \frac{2}{3} R^3.$$

4. Problems and exercises

1. Use Stokes formula to compute the circulation of the field $\vec{F}(y - z, z - x, x - y)$ along the intersection between the cylinder $x^2 + y^2 = a^2$ and the plane $\frac{x}{a} + \frac{z}{b} - 1 = 0, a > 0, b > 0$. The projection of the orientation of this curve on the xOy -plane is "from x to y ", i.e. the counterclockwise orientation.

2. Use Stokes formula to compute $I = \oint_C y dx + z dy + x dz$, where C is the intersection curve of the sphere $x^2 + y^2 + z^2 = a^2$ with the plane $x + y + z = a, a > 0$. The projection of the orientation of this curve on the xOy -plane is "from x to y ", i.e. the counterclockwise orientation.

3. Use Gauss formula to compute $I = \oint_S \oint x y z (x dy dz + y dz dx + z dx dy)$, where S is $x^2 + y^2 + z^2 = R^2, x \geq 0, y \geq 0, z \geq 0$, the interior side.

4. Use Gauss formula to compute $I = \oint_S \oint x y^2 dy dz + z^3 dz dx + y^2 z dx dy$, where S is the exterior side of the ellipsoid $\frac{x^2}{a^2} + \frac{y^2}{b^2} + \frac{z^2}{c^2} = 1$.

5. Use Gauss formula to compute $I = \oint_S \oint x^2 dy dz + y^2 dz dx + z^2 dx dy$, where S is the total interior side of the paraboloid: $x^2 + y^2 = z, 0 \leq z \leq 1$ together $x^2 + y^2 \leq 1, z = 1$, the "above" part.

6. Use Gauss formula to compute $I = \oint_S \oint x^2 dy dz + y^2 dz dx + z^2 dx dy$, where S is the exterior side of the sphere $(x - a)^2 + (y - b)^2 + (z - c)^2 = R^2$.

7. Compute in two ways the flux of the field $\vec{F} = (y - z)\vec{i} + (z - x)\vec{j} + (x - y)\vec{k}$ through the "open" surface $S: x^2 + y^2 = 4 - z, z > 0$, on the exterior side.

8. Compute the circulation of $\vec{F} = xy\vec{j} + xz\vec{k}$, along the circle C , the intersection between the sphere $x^2 + y^2 + z^2 = 4$ and the cone $x^2 + y^2 = 3z^3, z > 0$. The projection of the orientation of this curve on the xOy -plane is "from x to y ", i.e. the counterclockwise orientation.

9. Use Stokes formula to compute the circulation of $\vec{F} = x\vec{j} + y\vec{k}$ along the "closed" curve S , the intersection between the sphere $x^2 + y^2 + z^2 = R^2$ and the plane $x + y + z = 0$, with the orientation given by the direction of the vector $(1, 1, 1)$.

10. Let $\vec{F} = yz\vec{i} + 2xz\vec{j} - x^2\vec{k}$. Compute the flux of \vec{F} through the ellipsoid $4x^2 + y^2 + 4z^2 = 8$, the exterior side and the circulation of the same field along the intersection curve γ , the intersection between this last ellipsoid and the plane $z = 1$. The projection of the orientation of this curve on the xOy -plane is "from y to x ", i.e. the clockwise orientation.

Some remarks on complex functions integration

1. Complex functions integration

The reader can find some theory on complex numbers, complex sequences, complex series, complex functions, complex differentiability, etc. in [Po], sections 1.2, 5.2 and 11.8. We shall review some of them here.

To any point M of a plane (P) with a fixed direct oriented (counterclockwise) Cartesian coordinate system xOy or $\{O; \vec{i}, \vec{j}\}$ one can uniquely associate a pair (x, y) of two real numbers such that $\overrightarrow{OM} = x\vec{i} + y\vec{j}$. Conversely, to any pair $(x, y) \in \mathbb{R}^2$ we can uniquely associate a point M such that the position vector $\overrightarrow{OM} = x\vec{i} + y\vec{j}$. The ordered pair x and y are called the coordinates of M w.r.t. the Cartesian coordinate system xOy . We write this as $M(x, y)$. This double association give rise to the famous Descartes' bijection between the points of the plane (P) and the elements of the arithmetical space \mathbb{R}^2 . To the arithmetical sum $(x, y) + (x', y') = (x + x', y + y')$ from \mathbb{R}^2 one associates the point $N(x + x', y + y')$ and $\overrightarrow{ON} = \overrightarrow{OM} + \overrightarrow{OM'}$, where $M(x, y)$ and $M'(x', y')$. If $\alpha \in \mathbb{R}$ and $M(x, y)$ then, to the product $\alpha(x, y) = (\alpha x, \alpha y)$ from \mathbb{R}^2 we associate the point $T(\alpha x, \alpha y)$ and $\overrightarrow{OT} = \alpha\overrightarrow{OM}$. We see that the vector space \mathbb{R}^2 is isomorphic with the vector space V_2 of all free $2D$ -vectors. But \mathbb{R}^2 is also isomorphic with the vector space \mathbb{C} of all complex numbers $z = x + iy$, $x, y \in \mathbb{R}$, where $i = \sqrt{-1}$ is the pure imaginary quantity, not real, which denote one of the root of the equation $x^2 + 1 = 0$. With an appropriate multiplication, \mathbb{C} becomes a field, the complex number fields. The association $M(x, y) \rightsquigarrow z_M = x + iy \rightsquigarrow M_z(x, y)$ gives rise to a bijection between the points of the plane (P) and the complex numbers set \mathbb{C} . To the addition of \mathbb{C} corresponds the addition between the corresponding vectors in V_2 . The plane (P) becomes a representation of \mathbb{C} . The distance between two points $M(x, y)$ and $M'(x', y')$ in plane is exactly the distance $|z_M - z_{M'}|$ in \mathbb{C} . An ε -neighborhood of a fixed complex number z_0 is an open ball of the form $B(z_0, r) = \{z \in \mathbb{C} : |z - z_0| < r\}$, i.e. an open disc in the plane (P) with center at M_{z_0} and radius $r > 0$. An open

subset A of \mathbb{C} is a subset of \mathbb{C} with the property that if $z \in A$, then there exists a small $\varepsilon > 0$ such that the corresponding ε -neighborhood of z is contained in A . A subset D of \mathbb{C} is a *domain* if it is open and if it is connected, i.e. any two points M, N of D can be connected by a polygonal line (or a smooth curve) in D , with extremities at M and N respectively. D is bounded if there exists a real number $R > 0$ such that $D \subset B(0, R)$. In \mathbb{C} we have only "one" ∞ , the circle with centre at 0 and radius equal to ∞ (see the Riemann sphere construction in [Po], 6.5). A neighborhood of ∞ is the exterior of any closed ball of the form $B[0, R]$, i.e. $\{z \in \mathbb{C} : |z| > R\}$. A sequence $\{z_n\}$ of complex numbers is convergent to the complex number z if $|z_n - z| \rightarrow 0$, i.e. if and only if $x_n = \operatorname{Re} z_n \rightarrow x = \operatorname{Re} z$ and $y_n = \operatorname{Im} z_n \rightarrow \operatorname{Im} z$. Here $z_n = x_n + iy_n$ and $z = x + iy$. If A is a subset of real numbers, a function $f : A \rightarrow \mathbb{C}$, $f(t) = x(t) + iy(t)$, where $x : A \rightarrow \mathbb{R}$ and $y : A \rightarrow \mathbb{R}$ are the real functions components of f , is called a real function with complex values. The continuity, derivability and integrability of such functions are componentwise operations. Any continuous and injective function $g : [a, b] \rightarrow \mathbb{C}$, $g(t) = x(t) + iy(t)$, is called a curve in \mathbb{C} . In fact, the image $g([a, b])$ is the support curve of g , or simple a continuous curve in \mathbb{C} . If the real functions $x(t)$ and $y(t)$ are piecewise of class C^1 we say that the curve $\gamma = g([a, b])$ is a piecewise smooth curve. It has a length if and only if its parametric representation $\gamma : x = x(t), y = y(t)$,

$t \in [a, b]$ has a length and its length is $\int_{\gamma} ds$. Let A be a subset of \mathbb{C} and

let $f : A \rightarrow \mathbb{C}$ be a function defined on A with complex values. Such a function is called a complex function. Let $z = x + iy$ be a running point in A and let $f(z) = u(x, y) + iv(x, y)$. The real functions of two variables $(x, y) \rightsquigarrow u(x, y)$ and $(x, y) \rightsquigarrow v(x, y)$ are called the real part $\operatorname{Re} f$ of f and the imaginary part $\operatorname{Im} f$ of f respectively. We say that $f : D \rightarrow \mathbb{C}$ is continuous at a point z_0 of a fixed domain D , if for any sequence $\{z_n\}$ with elements of D and such that $z_n \rightarrow z_0$, one has that $f(z_n) \rightarrow f(z_0)$. We say that f is continuous on D if it is continuous at any point of D . Such a function is continuous on D if and only if its component real functions $u(x, y)$ and $v(x, y)$ are continuous on D . Here we simultaneously look at D as being in \mathbb{C} and in its corresponding representation plane (P) as a subset of \mathbb{R}^2 ! The differentiability (derivability) of a complex function $f : D \rightarrow \mathbb{C}$ is defined like the differentiability (derivability) of a real function of one variable with real values. We saw in theorem 91, [Po] that f is differentiable (or analytic) on the domain D if and only if its component functions u and v have continuous

partial derivatives on D and

$$(1.1) \quad \frac{\partial u}{\partial x} = \frac{\partial v}{\partial y}, \quad \frac{\partial u}{\partial y} = -\frac{\partial v}{\partial x}$$

(Cauchy-Riemann relations) and

$$(1.2) \quad f'(z) = \frac{\partial u}{\partial x}(x, y) + i \frac{\partial v}{\partial x}(x, y) = \frac{\partial v}{\partial y}(x, y) - i \frac{\partial u}{\partial y}(x, y)$$

Any power series $S(z) = \sum_{n=0}^{\infty} c_n(z - z_0)$ has a set of convergence M such that $B(z_0, R) \subset M \subset B[z_0, R]$, where R is called a convergence radius and it is computed exactly like in the real case:

$$(1.3) \quad R = \frac{1}{\limsup \sqrt[n]{|c_n|}} = \frac{1}{\limsup \left| \frac{c_{n+1}}{c_n} \right|}.$$

All the basic results relative to sequences or series of functions from the real case preserve in the complex functions case. For instance, if $\{f_n(z)\}$ is a sequence of complex functions, such that f_n is uniformly bounded by a number a_n , i.e. $|f_n(z)| \leq a_n$ for any $z \in D$, and the numerical series $\sum a_n$ is convergent, then the series of functions $\sum f_n$ is absolutely and uniformly convergent on D (Weierstrass M test). The proofs follows exactly the same ideas like in the real case.

We shall now introduce the integral $\int_{ab} f(z)dz$ of a complex function $f : D \rightarrow \mathbb{C}$ along a fixed arc of a curve $ab \subset D$. We assume that the arc ab is the image of $g : [T_0, T] \rightarrow \mathbb{C}$, $g(t) = x(t) + iy(t)$, where g is a continuous function of a real variable with complex values (a complex curve!). Let $\Delta : t_0 = T_0 < t_1 < \dots < t_n = T$ be a division of the real interval $[T_0, T]$ and let $\{c_i\}$, $c_i \in [t_{i-1}, t_i]$ be a set of marking points of this division. Let $z_j = g(t_j)$ and $\xi_j = g(c_j)$, where $j = 1, 2, \dots, n$, be the corresponding points on the arc ab (see Fig.1). Let $\Delta^* = \{z_j\}$ be the natural division of the arc ab obtained as the image of the division Δ of the real interval $[T_0, T]$.

A sum of the type

$$(1.4) \quad S_f(\Delta^*, \{\xi_j\}) = \sum_{j=1}^n f(\xi_j)(z_j - z_{j-1})$$

is called a *Riemann sum of f relative to the division Δ^* and the set of marking points $\{\xi_j\}$* .

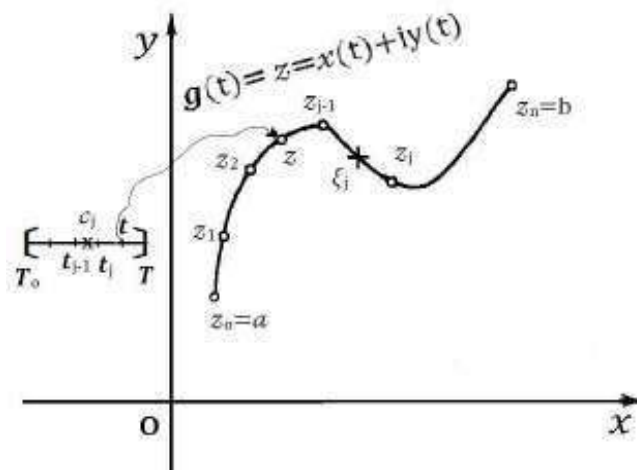

FIGURE 1

DEFINITION 33. We say that $f : D \rightarrow \mathbb{C}$ is integrable on the arc ab if there exists a complex number $I \stackrel{\text{def}}{=} \int_{ab} f(z) dz$ such that for any small $\varepsilon > 0$ there exists a small $\delta > 0$ (depending on ε) with the property that if $\|\Delta\| < \delta$, then $|I - S_f(\Delta^*, \{\xi_j\})| < \varepsilon$ for any set $\{\xi_j\}$ of marking points of Δ^* . This means that I can well be approximated with Riemann sums of the above type.

It is easy to see that if f is piecewise continuous and g is smooth, then f is integrable on the arc ab and

$$(1.5) \quad \int_{ab} f(z) dz = \int_{T_0}^T f(g(t)) g'(t) dt,$$

where $g'(t) = x'(t) + iy'(t)$. Indeed,

$$\sum_{j=1}^n f(\xi_j)(z_j - z_{j-1}) = \sum_{j=1}^n f(g(c_j)) [(x(t_j) - x(t_{j-1})) + i(y(t_j) - y(t_{j-1}))] =$$

$$(1.6) \quad \stackrel{\text{Lagrange}}{=} \sum_{j=1}^n f(g(c_j)) [x'(d_j) + iy'(e_j)] (t_j - t_{j-1}),$$

where $d_j, e_j, c_j \in [t_{j-1}, t_j]$. Since this interval is very small as $\|\Delta\| \rightarrow 0$, and since g' is continuous, we can well approximate the sum of (1.6)

with

$$\sum_{j=1}^n f(g(c_j)) [x'(c_j) + iy'(c_j)] (t_j - t_{j-1}),$$

which is a Riemann sum of $\int_{T_0}^T f(g(t))g'(t)dt$. Hence this last integral can

be well approximated with Riemann sums of the form $\sum_{j=1}^n f(\xi_j)(z_j - z_{j-1})$. This means that f is integrable on the arc ab and $\int_{ab} f(z)dz =$

$$\int_{T_0}^T f(g(t))g'(t)dt.$$

EXAMPLE 106. Let us compute $I_n = \int_{|z-z_0|=r} \frac{1}{(z-z_0)^n} dz$ for any natural number $n = 0, 1, \dots$. The equation $|z - z_0| = r$ describes a circle with centre at z_0 and radius r . It has the following parametrization $z = z_0 + r \exp(i\theta)$, where $\theta \in [0, 2\pi]$. It is equivalent to the real form $\begin{cases} x = x_0 + r \cos \theta \\ y = y_0 + r \sin \theta \end{cases}$, $\theta \in [0, 2\pi]$. Applying formula (1.5) we get:

$$I_n = \int_0^{2\pi} \frac{1}{r^n e^{in\theta}} r i e^{i\theta} d\theta = r^{-n+1} i \cdot \frac{e^{i\theta(1-n)}}{i(1-n)} \Big|_0^{2\pi} = 0,$$

if $n \neq 1$ and $I_1 = i \int_0^{2\pi} d\theta = 2\pi i$. Here we used the equality: $e^{2\pi mi} = \cos 2\pi m + i \sin 2\pi m = 1$ for any integer number m . Hence

$$(1.7) \quad \int_{|z-z_0|=r} \frac{1}{(z-z_0)^n} dz = \begin{cases} 0, & \text{if } n \neq 1 \\ 2\pi i, & n = 1. \end{cases}$$

We shall now express the complex integral $\int_{ab} f(z)dz$ as a complex number, with a real and an imaginary part. For this, let $\xi_j = \eta_j + i\theta_j$,

with $\eta_j, \theta_j \in \mathbb{R}$ and let us come back to the Riemann sum (1.4):

$$\begin{aligned} & \sum_{j=1}^n f(\xi_j)(z_j - z_{j-1}) = \\ &= \sum_{j=1}^n [u(\eta_j, \theta_j) + iv(\eta_j, \theta_j)] [(x(t_j) - x(t_{j-1})) + i(y(t_j) - y(t_{j-1}))] = \\ &= \sum_{j=1}^n [u(\eta_j, \theta_j)(x(t_j) - x(t_{j-1})) - v(\eta_j, \theta_j)(y(t_j) - y(t_{j-1}))] + \\ &+ i \sum_{j=1}^n [u(\eta_j, \theta_j)(y(t_j) - y(t_{j-1})) + v(\eta_j, \theta_j)(x(t_j) - x(t_{j-1}))]. \end{aligned}$$

Since the real part of this last sum is a Riemann sum for the line integral $\oint_{ab} u dx - v dy$ and since the imaginary part is a Riemann sum

for the line integral $\oint_{ab} v dx + u dy$, we find that:

$$(1.8) \quad \int_{ab} f(z) dz = \oint_{ab} u dx - v dy + i \oint_{ab} v dx + u dy.$$

Let us compute $\int_{\gamma} (3xy + y^2 i) dz$, where γ is the oriented segment $[AB]$ with $A(0, 0)$ and $B(1, 2)$. Since $u(x, y) = 3xy$ and $v(x, y) = y^2$ can be easily computed, we use formula (1.8). A parametrization for $[AB]$ is $x = x, y = 2x, x \in [0, 1]$. Hence,

$$\int_{ab} f(z) dz = \int_0^1 (6x^2 - 8x^2) dx + i \int_0^1 (4x^2 + 12x^2) dx = -\frac{2}{3} + i\frac{16}{3}.$$

THEOREM 97. (*Cauchy fundamental theorem*) Let D be a simple connected domain of \mathbb{C} and let $f : D \rightarrow \mathbb{C}$ be a differentiable (analytic) complex function defined on D . Then, for any piecewise smooth

"closed" oriented curve $\gamma \subset D$, one has that $\oint_{\gamma} f(z) dz = 0$.

PROOF. Since f is differentiable one has that $\frac{\partial u}{\partial x} = \frac{\partial v}{\partial y}$, $\frac{\partial u}{\partial y} = -\frac{\partial v}{\partial x}$. We can apply Green formula (3.1), Ch.6, for the both line integrals on the right side of the equality, which results from formula (1.8):

$$\begin{aligned} \oint_{\gamma} f(z)dz &= \oint_{\gamma} udx - vdy + i \oint_{\gamma} vdx + udy = \\ &= \iint_{D_{\gamma}} \left(-\frac{\partial u}{\partial y} - \frac{\partial v}{\partial x} \right) dx dy + i \iint_{D_{\gamma}} \left(-\frac{\partial v}{\partial y} + \frac{\partial u}{\partial x} \right) dx dy = 0, \end{aligned}$$

where D_{γ} is the domain bounded by γ (see Fig.2) □

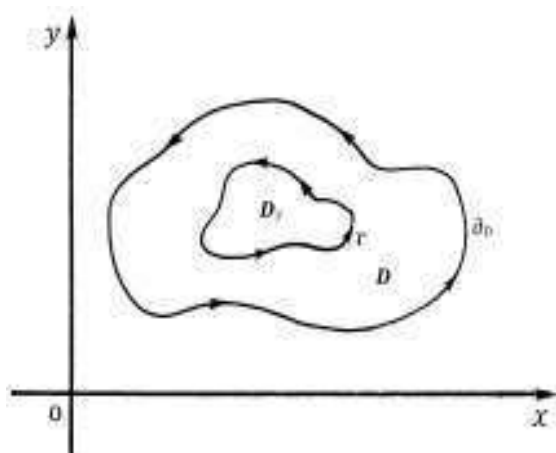

FIGURE 2

The simple connected property of D is necessary. Indeed, for instance

$$\int_{|z-z_0|=r} \frac{1}{z-z_0} dz = 2\pi i \neq 0$$

(see formula (1.7)) because $D = \mathbb{C} \setminus \{z_0\}$ is not simple connected.

A main consequence of this Cauchy fundamental theorem is the possibility to construct a primitive function $F(z)$ for an analytic function

$f(z)$ defined on a simple connected domain D . The formula $\oint_{\gamma} f(z)dz = 0$ for any piecewise smooth "closed" oriented curve $\gamma \subset D$, implies like usually that the complex integral $\int_A^B f(z)dz$ does not depend on

the complex path Γ which connects the points A and B . Hence, if one fixes a point z_0 in D and if z is an arbitrary point in D , then

$$F(z) = \int_{z_0}^z f(\zeta) d\zeta \text{ is a primitive function for } f(z), \text{ i.e. } F(z) \text{ is differen-}$$

tiable and $F'(z) = f(z)$ for any $z \in D$ (see Fig.3). The proof of this statement is almost similar to the proof of the analogous result for line integrals of the second type (see also the remark 22). Indeed, let w_0 be a point in D and let a closed disc $B[w_0, r] = \{z \in \mathbb{C} : |z - w_0| \leq r\}$ with centre at w_0 and radius $r > 0$, sufficiently small such that $B[w_0, r] \subset D$. Since D is connected, there exists a polygonal line $[z_0 w_0] \subset D$, which connect z_0 and w_0 . For any $w \in B[w_0, r]$, let us evaluate the quotient:

$$\begin{aligned} \frac{F(w) - F(w_0)}{w - w_0} &= \frac{\int_{[z_0 w_0]} f(\zeta) d\zeta + \int_{\text{segm}[w_0 w]} f(\zeta) d\zeta - \int_{[z_0 w_0]} f(\zeta) d\zeta}{w - w_0} = \\ &= \frac{\int_{\text{segm}[w_0 w]} f(\zeta) d\zeta}{w - w_0}, \end{aligned}$$

where $\text{segm}[w_0 w]$ is the segment of the straight line which connect w_0 and w (see Fig.3).

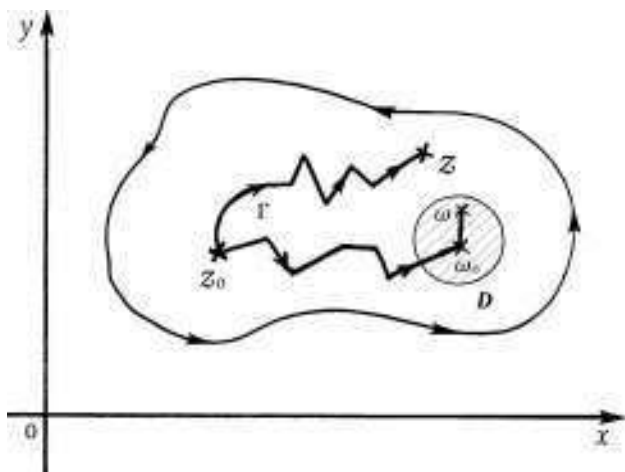

FIGURE 3

Since our goal is to prove that

$$\lim_{w \rightarrow w_0} \frac{F(w) - F(w_0)}{w - w_0} = f(w_0),$$

let us evaluate now the distance between $\frac{F(w)-F(w_0)}{w-w_0}$ and $f(z)$:

$$\begin{aligned} \left| \frac{F(w) - F(w_0)}{w - w_0} - f(w_0) \right| &= \frac{\left| \int_{\text{segm}[w_0w]} f(\zeta) d\zeta - \int_{\text{segm}[w_0w]} f(w_0) d\zeta \right|}{|w - w_0|} \leq \\ &\leq \frac{\int_{\text{segm}[w_0w]} |f(\zeta) - f(w_0)| |d\zeta|}{|w - w_0|} \leq \sup_{\zeta \in \text{segm}[w_0w]} |f(\zeta) - f(w_0)|. \end{aligned}$$

Since f is continuous on D , this last supremum goes to zero when $w \rightarrow w_0$. Hence, $\left| \frac{F(w)-F(w_0)}{w-w_0} - f(w_0) \right| \rightarrow 0$, when $w \rightarrow w_0$, i.e. $\lim_{w \rightarrow w_0} \frac{F(w)-F(w_0)}{w-w_0} = f(w_0)$, i.e. F is differentiable at w_0 and $F'(w_0) = f(w_0)$.

What happens when D is not simple connected, i.e. if it has some "gaps" or "holes"? We shall describe in the following a very simple model of a n -connected domain Ω . We start with a complex domain D^* and let us consider another simple connected bounded domain $D \subset D^*$ such that $\overline{D} = D \cup \partial D \subset D^*$. Let D_1, D_2, \dots, D_{n-1} be $n - 1$ nonoverlapping (the intersection $D_i \cap D_j$, $i \neq j$, is empty or at most a piecewise smooth curve) domains contained in D . We assume that the boundary $\partial D = \Gamma_0^+$ is a directly oriented piecewise smooth curve and the boundaries $\partial D_1 = \Gamma_1^-, \dots, \partial D_{n-1} = \Gamma_{n-1}^-$ are included in D and they are piecewise smooth inverse oriented curves (see Fig.4). Then $\Omega = D \setminus \bigcup_{j=1}^{n-1} \overline{D}_j$ is said to be a n -connected domain. For $n = 1$ we get $\Omega = D$ itself, i.e. a simple connected domain. For $n = 2$, $\Omega = D \setminus \overline{D}_1$ and we obtain a double connected domain (with a "hole"), etc. To obtain from Ω a new simple connected domain Ω_* , it is enough to get out from it $n - 1$ piecewise smooth curves $\gamma_1, \dots, \gamma_{n-1}$ which connect ∂D with $\partial D_1, \dots, \partial D_{n-1}$ respectively, traced twice in the opposite directions (see Fig.4).

Hence Ω_* , which has as its boundary the union between $\partial D, \partial D_1, \dots, \partial D_{n-1}$ and $\gamma_1, \dots, \gamma_{n-1}$ traced twice each of them, is a simple connected domain.

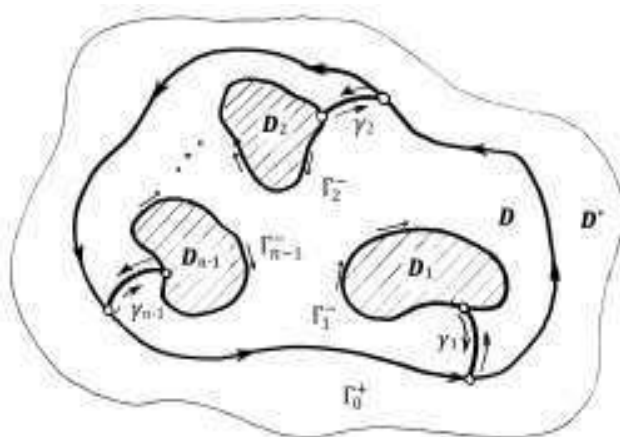

FIGURE 4

THEOREM 98. (*n*-connected Cauchy fundamental theorem) *With these notation and hypotheses, let $f : D^* \setminus \cup_{j=1}^{n-1} D_j \rightarrow \mathbb{C}$ be a continuous function which is analytic on Ω . Then,*

$$(1.9) \quad \int_{\Gamma_0^+} f(z)dz = \int_{\Gamma_1^+} f(z)dz + \int_{\Gamma_2^+} f(z)dz + \dots + \int_{\Gamma_{n-1}^+} f(z)dz.$$

In particular, if $h : \bar{D} \rightarrow \mathbb{C}$ is a continuous function which is analytic on D except the points z_1, z_2, \dots, z_m of D (see Fig.5), then one can uniquely define the numbers $res(f, z_j) \stackrel{def}{=} \frac{1}{2\pi i} \int_{|z-z_j|=r_j} f(z)dz, j = 1, 2, \dots, m$ for any $r_j > 0$ sufficiently small such that $B(z_j, r_j) \subset D$ and $B(z_j, r_j) \cap B(z_k, r_k) = \emptyset$ for $j \neq k$. Here $res(f, z_j)$ is said to be the residue of f at z_j . Moreover, formula (1.9) immediately implies the famous "residues formula":

$$(1.10) \quad \int_{\Gamma_0^+} f(z)dz = 2\pi i \sum_{j=1}^m res(f, z_j).$$

PROOF. It is sufficient to apply the Cauchy fundamental theorem for the simple connected domain Ω_* and taking count that the curves $\gamma_1, \dots, \gamma_{n-1}$ are traced twice in the opposite directions:

$$\int_{\Gamma_0^+} f(z)dz + \sum_{j=1}^{n-1} \int_{\Gamma_j^-} f(z)dz + \sum_{j=1}^{n-1} \int_{\gamma_j^-} f(z)dz + \sum_{j=1}^{n-1} \int_{\gamma_j^+} f(z)dz = 0,$$

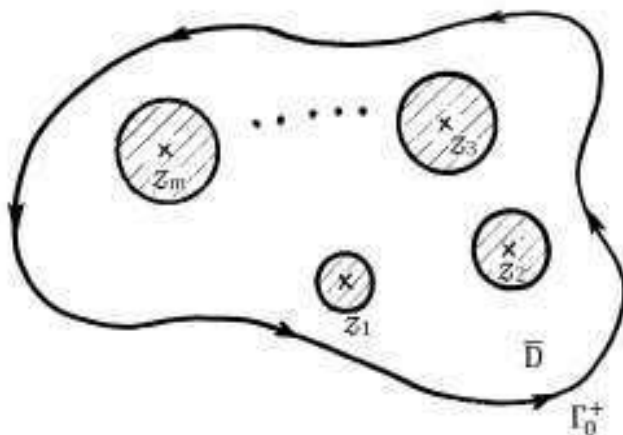

FIGURE 5

or

$$\int_{\Gamma_0^+} f(z)dz = \sum_{j=1}^{n-1} \int_{\Gamma_j^+} f(z)dz.$$

The residue $res(f, z_j) \stackrel{def}{=} \frac{1}{2\pi i} \int_{|z-z_j|=r_j} f(z)dz$ is well defined because if

we diminish the radius r_j of the disc to another one $0 < r_j^* < r_j$ then, on the annulus $\{z \in \mathbb{C} : r_j^* < |z - z_j| < r_j\}$ the function $f(z)$ is analytic and, applying the first statement of this theorem, we get

that $\frac{1}{2\pi i} \int_{|z-z_j|=r_j} f(z)dz = \frac{1}{2\pi i} \int_{|z-z_j|=r_j^*} f(z)dz$, i.e. the residue $res(f, z_j)$ is

well defined. The equality (1.10) is the particular case of the general Cauchy formula (1.9), where we take the discs $|z - z_j| < r_j$ for the domains D_j . \square

REMARK 37. Let H be a complex domain, let D be a bounded domain included in H such that $\partial D = \Gamma$ is a direct oriented, continuous and piecewise smooth curve. Let f be an analytic function on H , except a finite number of points z_1, z_2, \dots, z_m inside D and a finite number of points w_1, w_2, \dots, w_s which are on $\partial D = \Gamma$ (see Fig.6). If in a small neighborhood V_j of w_j , which does not contain any other w_t , the curve Γ is smooth, then we say that the angle in radians attached to w_j is $\alpha_j = \pi$. If w_h is an angular point on Γ and the angle in radians between the two distinct tangent lines at w_h to Γ is α_h , we attach this α_h to w_h

(here α_h measure the "openness" of the point w_h relative to the domain D ; more exactly, we take a small disk $B(w_h, r)$ and consider the sector of it bounded by the two tangent lines and which contains a region of D). Then, the above residues formula can be generalized as follows:

$$(1.11) \quad \int_{\Gamma^+} f(z)dz = 2\pi i \sum_{j=1}^m \text{res}(f, z_j) + i \sum_{j=1}^s \alpha_j \cdot \text{res}(f, w_j)$$

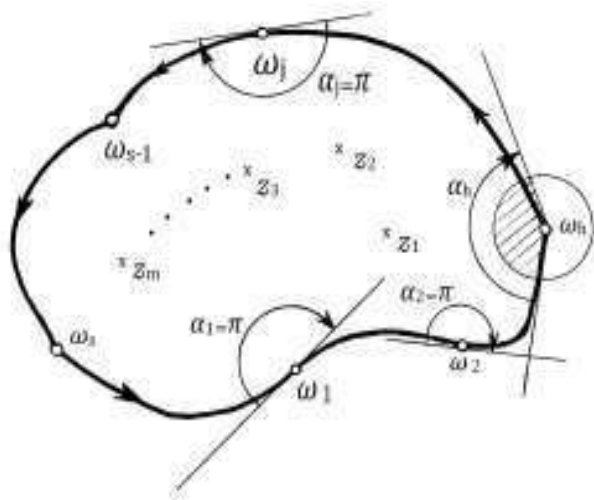

FIGURE 6

We shall try in the following to compute such a new number $\text{res}(f, z_0) = \frac{1}{2\pi i} \int_{|z-z_0|=r} f(z)dz$ for a function f which is analytic on the disc $|z - z_0| < r$, except the point z_0 , its centre. Then, we shall apply the residues formula (1.10) in order to compute some complicated real or complex integrals. But what about the ∞ point of $\overline{\mathbb{C}} = \mathbb{C} \cup \{\infty\}$? (see the Riemann sphere in [Po], 6.5). To study the behavior of a function f in a neighborhood $V_{\infty, R} = \{z \in \mathbb{C} : |z| > R\}$ of infinite means to study the behavior of the functions $g(w) = f(1/w)$ in the corresponding neighborhood $V_{0, 1/R} = \{w \in \mathbb{C} : |w| < 1/R\}$ and then to come back to ∞ with the obtained informations. Let us assume that a complex function f is analytic on \mathbb{C} except a finite set of points z_1, z_2, \dots, z_k . Let $R > 0$ large enough such that $|z_j| < R$ for $j = 1, 2, \dots, k$. We define

$$(1.12) \quad \text{res}(f, \infty) \stackrel{\text{def}}{=} \frac{1}{2\pi i} \int_{\gamma^-} f(z)dz,$$

where γ is the circle $|z| = R$. We take γ with its inverse direction because the neighborhood $V_{\infty, R} = \{z \in \mathbb{C} : |z| > R\}$ of ∞ has as its boundary with direct orientation, from the point of view of ∞ , exactly the oriented curve γ^- . Now, formula (1.10) says:

$$(1.13) \quad \operatorname{res}(f, \infty) + \sum_{j=1}^k \operatorname{res}(f, z_j) = 0.$$

Sometimes this formula is very useful because, if the number k is large, to compute separately each residue and to make their sum can be very difficult. Instead of doing this, formula 1.13 says that it is sufficient to compute $-\operatorname{res}(f, \infty)$. But, how to compute all this residues without complex integrals?

We saw in [Po] that many elementary functions are defined by complex power series. A general form of a complex power series at z_0 (related to this fixed point!) is the following:

$$(1.14) \quad f(z) = \dots + \frac{a_{-n}}{(z - z_0)^n} + \frac{a_{-n+1}}{(z - z_0)^{n+1}} + \dots + \frac{a_{-1}}{(z - z_0)} + a_0 + a_1(z - z_0) +$$

$$(1.15) \quad + a_2(z - z_0)^2 + \dots + a_n(z - z_0)^n + \dots = \sum_{n=-\infty}^{\infty} a_n(z - z_0)^n.$$

where a_n , $n \in \mathbb{Z}$ are the coefficients of this series. The series itself is called a Laurent series. It can be proved (see [Kra], or [ST]) that always exist $0 \leq r < R \leq \infty$ such that the series is convergent on the maximum open annulus $\{z \in \mathbb{C} : r < |z - z_0| < R\}$ and uniformly convergent on any closed annulus of the form $\{z \in \mathbb{C} : r' \leq |z - z_0| \leq R'\}$ for any r', R' with $r < r' \leq R' < R$. If all the negative indexed coefficients $a_{-1}, a_{-2}, \dots, a_{-n}, \dots$ are zero, then $r = 0$ and the series is convergent on a maximum open disc $B(z_0, R)$ with centre at z_0 and of radius R . For instance,

$$e^{z-1} = 1 + \frac{1}{1!}(z-1) + \frac{1}{2!}(z-1)^2 + \dots + \frac{1}{n!}(z-1)^n + \dots$$

has $r = 0$, $R = \infty$ and the series is convergent on the entire plane, but not in ∞ , where it does not exist like an usual function ($\lim_{z \rightarrow \infty} e^{z-1}$ does not exist because $\lim_{n \rightarrow \infty} e^{2n\pi i} = 1$ and $\lim_{n \rightarrow \infty} e^n = \infty$). For

$$e^{\frac{1}{z}} = 1 + \frac{1}{1!z} + \frac{1}{2!z^2} + \dots + \frac{1}{n!z^n} + \dots$$

$r = 0$, $R = \infty$, but the series is not defined at $z = 0$. It is defined at ∞ and its values is 1 at this point.

Let us now compute the residue of $f(z)$ from formula (1.15) by taking the integral on a circle $|z - z_0| = \rho$, with $r < \rho < R$:

$$(1.16) \quad \operatorname{res}(f, z_0) = \frac{1}{2\pi i} \sum_{n=-\infty}^{\infty} a_n \int_{|z-z_0|=\rho} (z - z_0)^n dz = a_{-1},$$

because of the formulas (1.7). We can express the residue of f at a point z_0 even in a more simple way if all the negative indexed coefficients a_{-n} are zero except a finite number of them, starting with $a_{-k} \neq 0$, i.e. $a_{-k-1} = a_{-k-2} = \dots = a_{-n} = \dots = 0$. Then we see that

$$(z - z_0)^k f(z) = a_{-k} + a_{-k+1}(z - z_0) + \dots + a_{-1}(z - z_0)^{k-1} + a_0(z - z_0)^k + \dots$$

Hence

$$(1.17) \quad \operatorname{res}(f, z_0) = a_{-1} = \frac{1}{(k-1)!} \lim_{z \rightarrow z_0} [(z - z_0)^k f(z)]^{(k-1)}.$$

Here the exponent $(k-1)$ means the derivative of order $(k-1)$ of the function $(z - z_0)^k f(z)$. We say that z_0 is a pole of order k for the function f .

EXAMPLE 107. Let us use the residues formula (1.11) and formulas (1.17), (1.16) to compute the complex integrals a) $I(r) = \int_{|z-i|=r} \frac{\sin \frac{1}{z}}{(z^2+2)^2} dz$

and b) $J = \int_{[tuv]} \frac{1}{z^2(z^2-1)} dz$, where $[tuv]$ is the perimeter line, direct oriented, of the triangle with vertices $t = 0$, $u = 1$ and $v = i$.

To compute $I(r)$ we need to compute all the finite nonzero residues of $f(z) = \frac{\sin \frac{1}{z}}{(z^2+2)^2}$, i.e. the residue in at most the singular points (the points at which the function is not analytic) of $f(z)$. We easily see that $z_0 = 0$ is an essential singular point (see the definition bellow) of f because $\sin \frac{1}{z} = \frac{1}{z} - \frac{1}{3!z^3} + \dots$ and $\frac{1}{(z^2+2)^2}$ is analytic (differentiable) in a small neighborhood of $z_0 = 0$. The points $z_1 = i\sqrt{2}$ and $z_2 = -i\sqrt{2}$ are poles of order 2 because, for instance, the function $g(z) = (z - i\sqrt{2})^2 f(z)$ is analytic in a small neighborhood of $i\sqrt{2}$ which does not contain the points $z_0 = 0$ and $z_2 = -i\sqrt{2}$, etc. It is clear enough that $\operatorname{res}(f, z_0) = c_{-1} = \frac{1}{4}$. Now, to compute the residues $\operatorname{res}(f, z_1)$ and $\operatorname{res}(f, z_2)$ we need formula (1.17):

$$\operatorname{res}(f, z_0) = \frac{1}{(k-1)!} \lim_{z \rightarrow z_0} [(z - z_0)^k f(z)]^{(k-1)}.$$

Thus,

$$\begin{aligned}
 \operatorname{res}(f, z_1) &= \lim_{z \rightarrow i\sqrt{2}} \left[\frac{\sin \frac{1}{z}}{(z + i\sqrt{2})^2} \right]' = \\
 &= \lim_{z \rightarrow i\sqrt{2}} \frac{-\frac{1}{z^2}(z + i\sqrt{2})^2 \cos \frac{1}{z} - 2(z + i\sqrt{2}) \sin \frac{1}{z}}{(z + i\sqrt{2})^4} = \\
 &= \frac{i\sqrt{2} \sin \frac{i}{\sqrt{2}} - \cos \frac{i}{\sqrt{2}}}{16}. \\
 \operatorname{res}(f, z_2) &= \lim_{z \rightarrow -i\sqrt{2}} \left[\frac{\sin \frac{1}{z}}{(z - i\sqrt{2})^2} \right]' = \\
 &= \lim_{z \rightarrow -i\sqrt{2}} \frac{-\frac{1}{z^2}(z - i\sqrt{2})^2 \cos \frac{1}{z} - 2(z - i\sqrt{2}) \sin \frac{1}{z}}{(z - i\sqrt{2})^4} = \\
 &= \frac{-i\sqrt{2} \sin \frac{i}{\sqrt{2}} - \cos \frac{i}{\sqrt{2}}}{16}.
 \end{aligned}$$

We can now start the discussion. If $r < \sqrt{2} - 1$, then inside the circle $|z - i| = r$ there exists no singular point for f . Thus, in this case $I(r) = 0$. If $r = \sqrt{2} - 1$, then z_1 is on the circle $|z - i| = \sqrt{2} - 1$ and we apply formula (1.11) (we say that at z_1 we have a semiresidue. Hence, $I(\sqrt{2} - 1) = \pi i \frac{i\sqrt{2} \sin \frac{i}{\sqrt{2}} - \cos \frac{i}{\sqrt{2}}}{16}$. If $\sqrt{2} - 1 < r < 1$, then z_1 is inside the circle $|z - i| = \sqrt{2} - 1$, so that $I(r) = 2\pi i \frac{i\sqrt{2} \sin \frac{i}{\sqrt{2}} - \cos \frac{i}{\sqrt{2}}}{16}$. If $r = 1$, then, besides z_1 , one has a semiresidue at z_0 and $I(1) = 2\pi i \frac{i\sqrt{2} \sin \frac{i}{\sqrt{2}} - \cos \frac{i}{\sqrt{2}}}{16} + \pi i$. If $1 < r < 1 + \sqrt{2}$, then we have residues at z_0 and z_1 inside the circle, so $I(r) = 2\pi i \frac{i\sqrt{2} \sin \frac{i}{\sqrt{2}} - \cos \frac{i}{\sqrt{2}}}{16} + 2\pi i$. If $r = 1 + \sqrt{2}$, then we have residues at z_0 and z_1 inside the circle and a semiresidue at z_2 , so that $I(1 + \sqrt{2}) = 2\pi i \frac{i\sqrt{2} \sin \frac{i}{\sqrt{2}} - \cos \frac{i}{\sqrt{2}}}{16} + 2\pi i + \pi i \frac{-i\sqrt{2} \sin \frac{i}{\sqrt{2}} - \cos \frac{i}{\sqrt{2}}}{16}$. If $r > 1 + \sqrt{2}$, we have all the three points as residues inside the circle, so that $I(r) = 2\pi i \frac{i\sqrt{2} \sin \frac{i}{\sqrt{2}} - \cos \frac{i}{\sqrt{2}}}{16} + 2\pi i + 2\pi i \frac{-i\sqrt{2} \sin \frac{i}{\sqrt{2}} - \cos \frac{i}{\sqrt{2}}}{16}$.

To compute $J = \int \frac{1}{z^2(z^2-1)} dz$, we can use formula (1.11). One has

a residue at $t = 0$, with the associated angle $\alpha_1 = \frac{\pi}{2}$ and a residue at $u = 1$, with the associated angle $\alpha_2 = \frac{\pi}{4}$. But, denoting $h(z) = \frac{1}{z^2(z^2-1)}$, one has

$$\operatorname{res}(h, 0) = \lim_{z \rightarrow 0} \left[\frac{1}{z^2 - 1} \right]' = -\lim_{z \rightarrow 0} 2z(z^2 - 1)^{-2} = 0$$

and

$$\operatorname{res}(h, 1) = \lim_{z \rightarrow 1} \frac{1}{z^2(z+1)} = \frac{1}{2}.$$

Hence, $J = \frac{\pi}{2}i \cdot 0 + \frac{\pi}{4}i \cdot \frac{1}{2} = \frac{\pi i}{8}$.

If an infinite number of negative indexed terms a_{-n} are distinct of zero, we say that z_0 is an essential point. If all a_{-n} are zero, i.e. if

$$(1.18) \quad f(z) = a_0 + a_1(z - z_0) + \dots + a_n(z - z_0)^n + \dots$$

we say that f is analytic at z_0 and z_0 is a regular point of f . In this last situation we call the expansion on the right side, a Taylor expansion. It can be proved that any analytic function f in a disc $B(z_0, R)$ has a Taylor expansion of the type (1.18). Let us evaluate the coefficients a_n in this last case. For this, let us take a circle γ_r with centre at z_0 and an arbitrary radius $r > 0$ and let us integrate term by term:

$$\int_{\gamma_r} \frac{f(z)}{(z - z_0)^{n+1}} dz = \sum_{k=0}^{\infty} a_k \int_{\gamma_r} (z - z_0)^{k-n-1} dz = a_n \cdot 2\pi i,$$

because of formulas (1.7) ($\int_{\gamma_r} (z - z_0)^{k-n-1} dz = 0$ for $k < n$ and $\int_{\gamma_r} (z - z_0)^{k-n-1} dz = 2\pi i$ for $k = n$) and because of the Cauchy fundamental theorem (97) for $k > n$ (then $(z - z_0)^{k-n-1}$ is analytic and so $\int_{\gamma_r} (z - z_0)^{k-n-1} dz = 0$). Hence,

$$a_n = \frac{1}{2\pi i} \int_{\gamma_r} \frac{f(z)}{(z - z_0)^{n+1}} dz.$$

If we substitute γ_r with any other closed piecewise smooth curve γ which contains z_0 inside the interior of the domain bounded by γ , it is immediate from the general Cauchy fundamental theorem 98 that

$$(1.19) \quad a_n = \frac{1}{2\pi i} \int_{\gamma} \frac{f(z)}{(z - z_0)^{n+1}} dz.$$

Since $a_n = \frac{1}{n!} f^{(n)}(z_0)$ (compute this n -th derivative in the Taylor expansion (1.18)), one obtains:

$$(1.20) \quad f^{(n)}(z_0) = \frac{n!}{2\pi i} \int_{\gamma} \frac{f(z)}{(z - z_0)^{n+1}} dz.$$

For $n = 0$ we get the basic *Cauchy integral formula*:

$$(1.21) \quad f(z_0) = \frac{1}{2\pi i} \int_{\gamma} \frac{f(z)}{z - z_0} dz.$$

This formula supply us the value of f at any point z_0 of a bounded domain D with its boundary $\partial D = \gamma$, a continuous piecewise smooth curve. It can be proved independently and then we can recover the Taylor expansion of an analytic function $f(z)$ inside a disc or the Laurent series expansion for an analytic function defined in an annulus. Indeed, let us take a small $r > 0$ such that the disc $B(z_0, r) \subset D_{\gamma}$, the simple connected domain bounded by γ . The 2-connected Cauchy fundamental theorem (see theorem 98) says that

$$\frac{1}{2\pi i} \int_{\gamma} \frac{f(z)}{z - z_0} dz = \frac{1}{2\pi i} \int_{|z-z_0|=r} \frac{f(z)}{z - z_0} dz.$$

Let us use formula (1.7) to evaluate the difference:

$$\begin{aligned} \left| \frac{1}{2\pi i} \int_{|z-z_0|=r} \frac{f(z)}{z - z_0} dz - f(z_0) \right| &= \frac{1}{2\pi} \left| \int_{|z-z_0|=r} \frac{f(z)}{z - z_0} dz - \int_{|z-z_0|=r} \frac{f(z_0)}{z - z_0} dz \right| = \\ &= \frac{1}{2\pi} \int_{|z-z_0|=r} \frac{|f(z) - f(z_0)|}{|z - z_0|} |dz| \leq \frac{1}{2\pi r} \cdot 2\pi r \sup_{|z-z_0|=r} |f(z) - f(z_0)| \rightarrow 0, \end{aligned}$$

when r becomes smaller and smaller. Since the quantity

$$\left| \frac{1}{2\pi i} \int_{|z-z_0|=r} \frac{f(z)}{z - z_0} dz - f(z_0) \right|$$

does not depend on r , we see that it must be zero, i.e. we just obtained the basic Cauchy integral formula. Looking at the equality

$$f(w) = \frac{1}{2\pi i} \int_{|z-z_0|=r} \frac{f(z)}{z - w} dz$$

like at an integral with a parameter w and applying an analogous of Leibniz formula (1.7), we successively get:

$$f'(w) = \frac{1}{2\pi i} \int_{|z-z_0|=r} \frac{f(z)}{(z - w)^2} dz,$$

$$f''(w) = \frac{1 \cdot 2}{2\pi i} \int_{|z-z_0|=r} \frac{f(z)}{(z-w)^3} dz, \dots, f^{(n)}(w) = \frac{n!}{2\pi i} \int_{|z-z_0|=r} \frac{f(z)}{(z-w)^{n+1}} dz,$$

i.e. we just proved formula (1.20) and the amazing fact that if $f(z)$ in differentiable "once" on a simple connected domain D , then it has derivatives of an arbitrary order on D .

Now, let us come back to the Taylor expansion (1.18) of an analytic function $f(z)$ in a disc $B(z_0, R)$ and let $r < R$. Let us evaluate the

$$\text{coefficient } a_n = \frac{1}{2\pi i} \int_{\gamma: |z-z_0|=r} \frac{f(z)}{(z-z_0)^{n+1}} dz, \quad n = 0, 1, 2, \dots :$$

$$|a_n| \leq \frac{1}{2\pi} M \int_{\gamma: |z-z_0|=r} \frac{1}{r^{n+1}} |dz| = \frac{1}{2\pi} M \cdot \frac{1}{r^{n+1}} \cdot 2\pi r = \frac{M}{r^n},$$

where M is the greatest value of $|f(z)|$ when z runs on the compact subset $\{z : |z - z_0| = r\}$. The inequalities

$$(1.22) \quad |a_n| \leq \frac{M}{r^n}$$

are called the *Cauchy inequalities*. They are surprisingly used to prove the following basic theorems.

THEOREM 99. (Liouville theorem) *Let $f(z)$ be an analytic function in the entire complex plane such that its modulus is bounded. Then $f(z)$ must be a constant.*

PROOF. Since $f(z)$ is analytic in the entire plane and bounded by a number M , in formula 1.22 one can make $r \rightarrow \infty$ for each $n = 1, 2, \dots$. Hence $a_1, a_2, \dots, a_n, \dots$ are all zero, i.e. $f(z) = a_0$. \square

An immediate and deep application is the fact that some real functions which are bounded and nonconstant on the real line (see $\sin x$, $\cos x$, etc.) do not continue to be bounded as functions of a complex variable. For instance $|\sin z| > 1$ for an infinite number of values of z . Indeed, since $\sin z$ is analytic on the entire \mathbb{C} , then it cannot be bounded on \mathbb{C} (otherwise one can apply Liouville theorem and $\sin x$ would be constant!). But another important consequence of the Liouville theorem is the following basic result in Mathematics.

THEOREM 100. (the fundamental theorem of algebra) *Any nonconstant polynomial $P(z) = a_0 + a_1z + \dots + a_nz^n$ with complex coefficients has at least one root in \mathbb{C} . In particular it has all roots in \mathbb{C} and it can be written as a product of the form:*

$$P(z) = a_n(z - \zeta_1)(z - \zeta_2)\dots(z - \zeta_n),$$

where $\zeta_1, \zeta_2, \dots, \zeta_n$ are all the roots of the polynomial $P(z)$.

PROOF. Assume contrary, namely that $P(z)$ has no root in all complex plane. Then $f(z) = \frac{1}{P(z)}$ is analytic and bounded, because $\lim_{z \rightarrow \infty} f(z) = 0$. Indeed, since $\lim_{z \rightarrow \infty} f(z) = 0$, there exists a large number $T > 0$ such that $|f(z)| < 1$ for any $|z| > T$. Let M be the greatest value of $f(z)$ on the closed disc $B[0, T]$. Then $|f(z)| < 1 + M$ for any $z \in \mathbb{C}$, i.e. $f(z)$ is bounded and we can apply the above Liouville theorem and find that $f(z)$ is a constant function, i.e. $P(z)$ is constant, a contradiction, because we assumed that it is nonconstant. Hence $P(z)$ must have at least one root in \mathbb{C} . The other statements can be easily derived by using successively the Euclidean division algorithm for polynomials. \square

2. Applications of residues formula

a) How do we evaluate real integrals of the form $I = \int_0^{2\pi} R(\cos \theta, \sin \theta) d\theta$

Here $R(\cos \theta, \sin \theta)$ is a rational function of $\cos \theta$ and $\sin \theta$. This means a quotient $\frac{P(x,y)}{Q(x,y)}$ of two polynomials in two variables in which we substituted the variables x and y with $\cos \theta$ and $\sin \theta$ respectively. To compute the integral I , we make a change of variables: $z = e^{i\theta}$. Thus,

$$(2.1) \quad I = \frac{1}{i} \int_{|z|=1} R\left(\frac{1}{2}\left(z + \frac{1}{z}\right), \frac{1}{2i}\left(z - \frac{1}{z}\right)\right) \cdot \frac{1}{z} dz.$$

This last integral is a complex integral of a rational function

$$\frac{P(z)}{Q(z)} = R\left(\frac{1}{2}\left(z + \frac{1}{z}\right), \frac{1}{2i}\left(z - \frac{1}{z}\right)\right) \cdot \frac{1}{z}$$

in variable z . Since this last function has at most a finite number of poles (the zeros of $Q(z)$) inside the circle $|z| = 1$ (or on its circumference), we can apply the residue formula and get:

$$(2.2) \quad I = 2\pi i \cdot \frac{1}{i} \sum_{Q(z_k)=0} \operatorname{res}\left(\frac{P(z)}{Q(z)}, z_k\right).$$

For instance, if we want to compute the coefficient $a_m = \int_0^{2\pi} \frac{\cos mx}{2+\sin x} dx$ of the Fourier expansion of the function $f(x) = \frac{1}{2+\sin x}$, $x \in [0, 2\pi]$ (see

"Fourier series" chapter in any course of Advanced Mathematics), the best idea is to use the above change of variables: $z = e^{ix}$. Thus,

$$\begin{aligned} a_m &= \frac{1}{i} \int_{|z|=1} \frac{1}{2} \cdot \frac{1+z^{2m}}{z^m} \cdot \frac{2iz}{z^2+4iz-1} \cdot \frac{1}{z} dz = \\ &= \int_{|z|=1} \frac{1}{z^m(z^2+4iz-1)} dz + \int_{|z|=1} \frac{z^m}{z^2+4iz-1} dz. \end{aligned}$$

b) Integrals of the form $\int_{-\infty}^{\infty} f(x) dx$

These improper integrals of the first type can be easily computed by using residues formula. First of all we need an auxiliary result.

THEOREM 101. *Let $f(z)$ be an analytic function everywhere in the upper half-plane $\{z \in \mathbb{C} : \text{Im } z > 0\}$, except a finite number of points z_1, z_2, \dots, z_n . We assume that in a neighborhood $|z| > R_0 > 0$ of ∞ the function $f(z)$ is bounded as follows: $|f(z)| < \frac{M}{|z|^{1+\delta}}$, where $M > 0$ and $\delta > 0$. Then*

$$(2.3) \quad \lim_{R \rightarrow \infty} \int_{C'_R} f(z) dz = 0,$$

where C'_R is a semicircle $|z| = R$, with $\text{Im } z > 0$ (see Fig. 7)

PROOF. Let us take $R > R_0$ and write:

$$\left| \int_{C'_R} f(z) dz \right| \leq \int_{C'_R} |f(z)| |dz| < \int_{C'_R} \frac{M}{|z|^{1+\delta}} |dz| = \frac{\pi M}{R^\delta},$$

which goes to zero when $R \rightarrow \infty$. Hence $\int_{C'_R} f(z) dz \rightarrow 0$ when $R \rightarrow \infty$

and the theorem is completely proved. \square

Now we can prove the basic result which will help us to compute improper integrals just announced.

THEOREM 102. *Let $f(x)$ be a real function of class C^∞ , defined on the entire real axis and let $f(z)$ be a unique (see [Po], section 11.8) analytic prolongation of it to the upper half-plane $\text{Im } z > 0$. We assume*

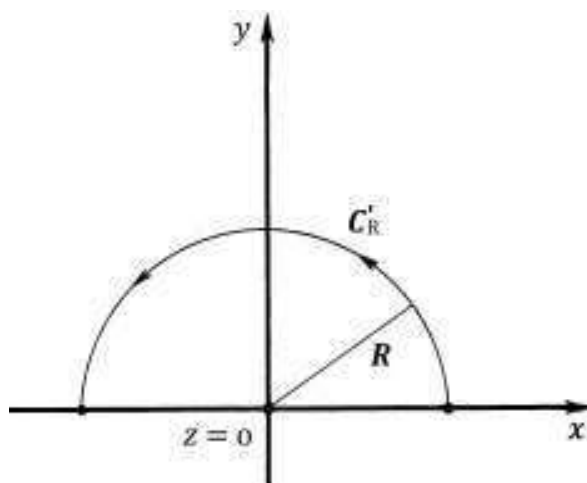

FIGURE 7

that the function $f(z)$ satisfies the conditions of the above theorem 101.

Then our improper integral $\int_{-\infty}^{\infty} f(x)dx$ is convergent and:

$$(2.4) \quad \int_{-\infty}^{\infty} f(x)dx = 2\pi i \sum_{k=1}^n \text{res}(f, z_k),$$

where z_1, z_2, \dots, z_n are all the singular points (at which f is not analytical) of f in the upper half-plane $\text{Im } z > 0$. In particular, if $f(z) = \frac{P(z)}{Q(z)}$ is a rational function which satisfies the supplementary conditions that $\deg Q(z) \geq \deg P(z) + 2$ and that the equation $Q(z) = 0$ has no real root, then

$$(2.5) \quad \int_{-\infty}^{\infty} \frac{P(x)}{Q(x)} dx = 2\pi i \sum_{\text{Re } z_k > 0 \text{ and } Q(z_k)=0} \text{res}(f, z_k)$$

PROOF. Let us take R_0 large enough such that $|z_k| < R_0$ for any $k = 1, 2, \dots, n$. Now we consider in the upper half-plane the closed contour $[-R, R] \cup C'_R$ (see Fig.7). We apply the residue formula and find:

$$\int_{-R}^R f(x)dx + \int_{C'_R} f(z)dz = 2\pi i \sum_{k=1}^n \text{res}(f, z_k).$$

Since the conditions of theorem 101 are satisfied, taking limit when $R \rightarrow \infty$, we get exactly formula (2.4).

The last statement is true because, $f(z) = \frac{P(z)}{Q(z)}$ together with the above restrictions on the polynomials $P(z)$, $Q(z)$, satisfies the same conditions of theorem 101. \square

For instance, we know that the integral $I = \int_{-\infty}^{\infty} \frac{1}{x^4+1} dx$ is convergent but its computation is not so easy. We see that $|\frac{1}{z^4+1}| \leq \frac{1}{|z|^3}$, for $|z|$ large enough, i.e. $R_0 = 1$, for instance, $M = 1$ and $\delta = 2 > 0$ in theorem 101. Thus we can apply the last theorem. For this we need to find all the zeros of $z^4 + 1 = 0$ in the half-plane $\text{Im } z > 0$. The solutions of the equation $z^4 + 1 = 0$ are $z_{0,1,2,3} = e^{i\frac{\pi+2k\pi}{4}}$, $k = 0, 1, 2, 3$. But only $z_0 = e^{i\frac{\pi}{4}}$ and $z_1 = e^{i\frac{3\pi}{4}}$ are in the upper half-plane. Thus,

$$I = 2\pi i \left[\text{res} \left(\frac{1}{z^4 + 1}, e^{i\frac{\pi}{4}} \right) + \text{res} \left(\frac{1}{z^4 + 1}, e^{i\frac{3\pi}{4}} \right) \right].$$

But, there is a problem! Formula (1.17) is not practicable here! Why? Let us see:

$$\text{res} \left(\frac{1}{z^4 + 1}, e^{i\frac{\pi}{4}} \right) = \lim_{z \rightarrow z_0} \left[(z - z_0) \frac{1}{z^4 + 1} \right] = \frac{1}{(z_0 - z_1)(z_0 - z_2)(z_0 - z_3)}.$$

To compute this last number is not so easy. But, let us look carefully to the general formula 1.17 for the case of a simple pole z_0 , i.e. for $k = 1$ and for $f(z) = \frac{P(z)}{Q(z)}$, a rational function:

$$(2.6) \quad \text{res}(f, z_0) = \lim_{z \rightarrow z_0} (z - z_0) \frac{P(z)}{Q(z)} = \frac{P(z_0)}{\lim_{z \rightarrow z_0} \frac{Q(z) - Q(z_0)}{z - z_0}} = \frac{P(z_0)}{Q'(z_0)}.$$

Using this nice formula in our case, we get:

$$\text{res} \left(\frac{1}{z^4 + 1}, e^{i\frac{\pi}{4}} \right) = \frac{1}{4z^3} \Big|_{z=e^{i\frac{\pi}{4}}} = \frac{1}{4e^{i\frac{3\pi}{4}}}.$$

Finally we obtain

$$I = 2\pi i \left[\text{res} \left(\frac{1}{z^4 + 1}, e^{i\frac{\pi}{4}} \right) + \text{res} \left(\frac{1}{z^4 + 1}, e^{i\frac{3\pi}{4}} \right) \right] = \frac{\pi\sqrt{2}}{2}.$$

If the residues of f are in the lower half-plane and similar conditions for f are satisfied, a similar result is true (do it!).

c) Integrals of the form $\int_{-\infty}^{\infty} e^{iax} f(x) dx$

Such integrals appear in the computation of a Fourier integral (or a Fourier transform).

We begin with an auxiliary result.

THEOREM 103. (*Jordan's lemma*) Let $f(z)$ be an analytic function in the upper half-plane $\text{Im } z > 0$, except a finite number of points z_1, z_2, \dots, z_n . We also assume that there exists a real function $\mu(r)$, $r \geq 0$, such that $|f(z)| < \mu(r)$ for any z on the semicircle $|z| = r$, $\text{Im } z \geq 0$ and $\lim_{r \rightarrow \infty} \mu(r) = 0$. Then for any real number $a > 0$

$$(2.7) \quad \lim_{R \rightarrow \infty} \int_{C'_R} e^{iaz} f(z) dz = 0,$$

where C'_R is a semicircular arc $|z| = R$ in the upper half-plane $\text{Im } z \geq 0$.

PROOF. Let us make a change of variable, by putting $z = R \cdot e^{i\theta}$, where $0 \leq \theta \leq \pi$. We then obtain

$$(2.8) \quad \begin{aligned} \left| \int_{C'_R} e^{iaz} f(z) dz \right| &\leq \int_{C'_R} |e^{iaz}| |f(z)| |dz| \leq R\mu(R) \int_0^\pi |e^{iaz}| d\theta = \\ &= R\mu(R) \int_0^\pi e^{-aR \sin \theta} d\theta, \end{aligned}$$

because

$$\begin{aligned} |e^{iaz}| &= |e^{iaR \cdot e^{i\theta}}| = |e^{iaR(\cos \theta + i \sin \theta)}| = |e^{iaR \cos \theta}| |e^{-aR \sin \theta}| = \\ &= |\cos(aR \cos \theta) + i \sin(aR \cos \theta)| |e^{-aR \sin \theta}| = |e^{-aR \sin \theta}|. \end{aligned}$$

Let us evaluate the real simple integral

$$I = \int_0^\pi e^{-aR \sin \theta} d\theta = \int_0^{\frac{\pi}{2}} e^{-aR \sin \theta} d\theta + \int_{\frac{\pi}{2}}^\pi e^{-aR \sin \theta} d\theta.$$

Making the change of variables $\eta = \pi - \theta$ in the last integral, we find that

$$\int_{\frac{\pi}{2}}^\pi e^{-aR \sin \theta} d\theta = - \int_{\frac{\pi}{2}}^0 e^{-aR \sin \eta} d\eta = \int_0^{\frac{\pi}{2}} e^{-aR \sin \eta} d\eta = \int_0^{\frac{\pi}{2}} e^{-aR \sin \theta} d\theta.$$

Thus, $I = 2 \int_0^{\frac{\pi}{2}} e^{-aR \sin \theta} d\theta$. Since $[\tan \theta - \theta]' = \frac{1}{\cos^2 \theta} - 1 \geq 0$, the function $\theta \rightsquigarrow \tan \theta - \theta$ is increasing, so that $\tan \theta \geq \theta$ if $\theta \in [0, \frac{\pi}{2}]$. Now $[\frac{\sin \theta}{\theta}]' =$

$\frac{\theta \cos \theta - \sin \theta}{\theta^2} = \frac{\theta - \tan \theta}{\theta^2 \cos \theta} \leq 0$ if $\theta \in (0, \frac{\pi}{2})$. Hence the function $\theta \rightsquigarrow \frac{\sin \theta}{\theta}$ is decreasing and its least value on $(0, \frac{\pi}{2}]$ is $\frac{\sin \frac{\pi}{2}}{\frac{\pi}{2}} = \frac{2}{\pi}$, i.e. $\frac{\sin \theta}{\theta} \geq \frac{2}{\pi}$ or $\sin \theta \geq \frac{2}{\pi} \theta$. Therefore,

$$e^{-aR \sin \theta} \leq e^{-\frac{2aR}{\pi} \theta}$$

and

$$I \leq 2 \int_0^{\frac{\pi}{2}} e^{-\frac{2aR}{\pi} \theta} d\theta = -\frac{\pi}{aR} e^{-\frac{2aR}{\pi} \theta} \Big|_0^{\frac{\pi}{2}} = -\frac{\pi}{aR} [e^{-aR} - 1].$$

Since

$$\left| \int_{C'_R} e^{iaz} f(z) dz \right| \leq R \mu(R) \int_0^{\pi} e^{-aR \sin \theta} d\theta \leq \mu(R) \frac{\pi}{a} [1 - e^{-aR}]$$

and since $\mu(R) \rightarrow 0$, when $R \rightarrow \infty$, we obtain that

$$\left| \int_{C'_R} e^{iaz} f(z) dz \right| \rightarrow 0,$$

when $R \rightarrow \infty$. □

REMARK 38. a) If $a < 0$ and $f(z)$ satisfies all the conditions which appear in the statement of the theorem 103 for the lower half-plane $\text{Im } z \leq 0$, then the formula 2.7 is again true for any semicircular arc C'_R in the lower half of the xOy -plane. b) Similar assertions hold for $a = \pm i\lambda$, $\lambda > 0$, when we integrate on the right ($\text{Re } z \geq 0$, see Fig.8) or on the left ($\text{Re } z \leq 0$) half of the xOy -plane. We leave to the reader to state and prove such similar Jordan's lemmas. Such variations of Jordan's lemma are extensively used in operational calculus (Fourier and Laplace transforms).

THEOREM 104. Let $f(x)$ be a continuous real valued function defined on the entire real axis \mathbb{R} and let $f(z)$ be an extension of it into the entire upper half-plane $\text{Im } z \geq 0$. We assume that $f(z)$ satisfies the conditions of Jordan's lemma and that it is analytic in this upper half-plane with the exception of a finite number of points z_1, z_2, \dots, z_n in this half-plane, which are not on the real axis. Then the integral $\int_{-\infty}^{\infty} e^{iax} f(x) dx$, $a > 0$ exists and it can be computed as follows:

$$(2.9) \quad \int_{-\infty}^{\infty} e^{iax} f(x) dx = 2\pi i \sum_{k=1}^n \text{res} [e^{iaz} f(z), z_k].$$

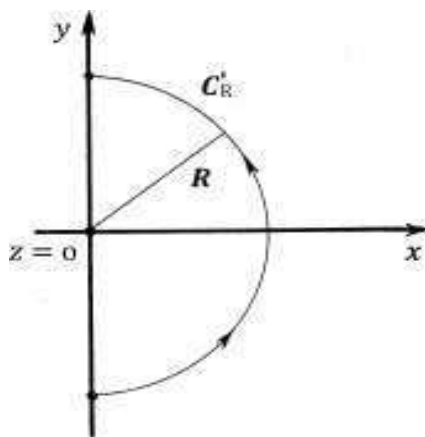

FIGURE 8

PROOF. Let R_0 be large enough such that $|z_k| < R_0$, $k = 1, 2, \dots, n$, i.e. all the singularities (the points at which f is not analytic) of f be inside the circle $|z| = R_0$. Take now $R > R_0$ and consider in the upper half-plane the following "closed" contour $\Gamma = [-R, R] \cup C'_R$, where C'_R is the semicircle of the circle $|z| = R$, which are in the upper-half plane of the xOy -plane (draw it!). By applying the residues formula (1.10) we get:

$$\int_{\Gamma^+} e^{iaz} f(z) dz = \int_{-R}^R e^{iax} f(x) dx + \int_{C'_R} e^{iaz} f(z) dz = 2\pi i \sum_{k=1}^n \text{res} [e^{iaz} f(z), z_k].$$

Making $R \rightarrow \infty$ and applying Jordan's lemma 103, we get formula (2.9). \square

EXAMPLE 108. In the operational calculus (Fourier transforms) we need to compute integrals of the form:

$$I_1 = \int_{-\infty}^{\infty} f(x) \cos nx \, dx, \quad I_2 = \int_{-\infty}^{\infty} f(x) \sin nx \, dx, \quad n = 0, 1, \dots$$

To do this we consider the following integral

$$I = I_1 + iI_2 = \int_{-\infty}^{\infty} e^{inx} f(x) \, dx$$

and try to apply formula (2.9) to it. For instance, let us compute $I_1 = \int_{-\infty}^{\infty} \frac{\cos nx}{x^2+h^2} \, dx$, where $h > 0$ is a real parameter and $n = 0, 1, 2, \dots$. Thus,

$$I = \int_{-\infty}^{\infty} \frac{e^{inx}}{x^2+h^2} \, dx = 2\pi i \cdot \text{res} \left[\frac{e^{inz}}{z^2+h^2}, ih \right] =$$

$$2\pi i \cdot \lim_{z \rightarrow ih} \left[(z - ih) \frac{e^{inz}}{z^2 + h^2} \right] = 2\pi i \cdot \frac{e^{-nh}}{2ih} = \frac{\pi}{h} e^{-nh}.$$

Thus $I_1 = \frac{\pi}{h} e^{-nh}$ and $I_2 = \int_{-\infty}^{\infty} \frac{\sin nx}{x^2 + h^2} dx = 0$ (this was obvious from the beginning because the function under the integration sign is odd and the interval is symmetric w.r.t. the origin).

EXAMPLE 109. (Computing Fresnel's integrals) In example 50 we proved that the Fresnel's integrals $I_1 = \int_0^{\infty} \cos x^2 dx$ and $I_2 = \int_0^{\infty} \sin x^2 dx$ are convergent. Let us compute them here. For this we naturally introduce the auxiliary complex function $f(z) = e^{iz^2}$. Let $A(r, 0)$, $B\left(\frac{r}{\sqrt{2}}, \frac{r}{\sqrt{2}}\right)$ and let γ_r be the arc of the circle $|z| = r$, between A and B . Let $\Gamma = [OA] \cup \gamma_r \cup [BO]$ with its direct orientation (draw it!). Applying Cauchy fundamental theorem 97 to the analytic function $f(z) = e^{iz^2}$, we get:

$$(2.10) \quad 0 = \int_{\Gamma^+} e^{iz^2} dz = \int_{[OA]} e^{ix^2} dx + \int_{\gamma_r} e^{iz^2} dz + \int_{[BO]} e^{iz^2} dz.$$

Now we show that

$$(2.11) \quad \lim_{r \rightarrow \infty} \int_{\gamma_r} e^{iz^2} dz = 0.$$

Indeed, putting $z^2 = w$, we obtain $dz = \frac{dw}{2\sqrt{w}}$, where \sqrt{w} is the first branch ($k = 0$) of the square root multivalued function $w = |w| e^{i \arg w} \rightsquigarrow \sqrt{|w|} e^{i \frac{\arg w + 2k\pi}{2}}$, $k = 0, 1$. Here $\theta = \arg w$ is the unique angle in $[0, 2\pi)$ which satisfies the relations: $\operatorname{Re} w = |w| \cos \theta$ and $\operatorname{Im} w = |w| \sin \theta$. Hence, if we denote $\Gamma_{r,2}$ the quarter of the circle $|w| = r^2$ situated in the first quadrant, one has:

$$\int_{\gamma_r} e^{iz^2} dz = \int_{\Gamma_{r,2}} \frac{e^{iw}}{2\sqrt{w}} dw = ir^2 \int_0^{\frac{\pi}{2}} \frac{e^{ir^2(\cos \theta + i \sin \theta)}}{2r e^{\frac{i\theta}{2}}} e^{i\theta} d\theta.$$

Since $|e^{i\theta}| = 1$ for any angle θ , we get:

$$\left| \int_{\gamma_r} e^{iz^2} dz \right| \leq \frac{r}{2} \int_0^{\frac{\pi}{2}} e^{-r^2 \sin \theta} d\theta \leq \frac{r}{2} \int_0^{\frac{\pi}{2}} e^{-r^2 \frac{2}{\pi} \theta} d\theta = \frac{r-2}{2r^2\pi} e^{-r^2 \frac{2}{\pi} \theta} \Big|_0^{\frac{\pi}{2}} = \frac{1}{r\pi} (1 - e^{-r^2}) \rightarrow 0,$$

when $r \rightarrow \infty$. Here we used again the inequality $\sin \theta \geq \frac{2}{\pi}\theta$ which was deduced during the proof of Jordan's lemma. Let us compute now the other two integrals of formula (2.10):

$$\int_{[OA]} e^{ix^2} dx = \int_0^r \cos x^2 dx + i \int_0^r \sin x^2 dx,$$

$$\int_{[BO]} e^{iz^2} dz \stackrel{z=\rho e^{i\frac{\pi}{4}}}{=} -e^{i\frac{\pi}{4}} \int_0^r e^{-\rho^2} d\rho.$$

Hence, formula (2.10) becomes:

$$\int_0^r \cos x^2 dx + i \int_0^r \sin x^2 dx = e^{i\frac{\pi}{4}} \int_0^r e^{-\rho^2} d\rho - \int_{\gamma_r} e^{iz^2} dz.$$

Taking limit when $r \rightarrow \infty$ and using formulas (2.11) and (2.21) we get:

$$\int_0^{\infty} \cos x^2 dx + i \int_0^{\infty} \sin x^2 dx = e^{i\frac{\pi}{4}} \frac{\sqrt{\pi}}{2} = \left[\frac{1}{\sqrt{2}} + i \frac{1}{\sqrt{2}} \right] \frac{\sqrt{\pi}}{2} = \frac{\sqrt{\pi}}{2\sqrt{2}} + i \frac{\sqrt{\pi}}{2\sqrt{2}}.$$

Hence

$$\int_0^{\infty} \cos x^2 dx = \int_0^{\infty} \sin x^2 dx = \frac{\sqrt{\pi}}{2\sqrt{2}}.$$

3. Problems and exercises

1. Find the real and imaginary parts of the functions:

a) $f(z) = \bar{z} - 3ie^z$; b) $f(z) = \sin z$; c) $f(z) = \tan z$; d) $f(z) = \frac{\bar{z}}{z+1}$.

2) Compute $\int_{\gamma} (1+i-2z)dz$, where γ is the segment of the straight line which connect $z_1 = 0$ and $z_2 = 2-i$.

3) Compute $\int_{\gamma} (1+z\bar{z})dz$, where γ is the semicircle $|z| = 3$, $0 \leq \arg z \leq \pi$.

4) Compute: a) $\int_i^{2-i} (3z-1)dz$; b) $\int_0^i z \sin z dz$; c) $\int_{-1}^{2+i} ze^{z^2} dz$;

5) Compute: a) $\int_{|z|=1} \frac{e^z}{z^3+3z} dz$; b) $\int_{|z-i|=1} \frac{e^{iz}}{z^2+1} dz$; c) $\int_{|z|=\frac{1}{3}} \frac{\sin z}{z^3} dz$;

d) $\int_{|z|=2} \frac{e^z dz}{z^3(z+1)}$; e) $\int_{|z|=1} z^3 \sin \frac{1}{z} dz$; f) $\int_{|z-1|=1} \frac{e^{2z}}{z^3-1} dz$;

g) $\int_{|z-2i|=a} \frac{1}{z^2(z^2+4)} dz$ (discussion on $a > 0$).

6) Compute: a) $\int_{-\infty}^{\infty} \frac{dx}{(x^2+4)^3}$; b) $\int_{-\infty}^{\infty} \frac{1}{32+x^6} dx$; c) $\int_{-\infty}^{\infty} \frac{dx}{(x^2+4x+6)^2}$;

d) $\int_{-\infty}^{\infty} \frac{\sin 5x}{x^2+4} dx$; e) $\int_0^{\infty} \frac{x^2 \cos 2x}{(x^2+2)^2} dx$; f) $\int_0^{\infty} \frac{\cos ax - \cos bx}{x^2} dx$, $a, b > 0$.

APPENDIX A

Exam samples

1. June, 2010

1. Find the area of the plane domain bounded by the curves: $y = \sqrt[3]{x^2}$, $y = \frac{1}{4+x^2}$, $x = 2$ and $x = 2\sqrt{3}$.
2. Prove that the integral $I(a) = \int_0^\infty \frac{e^{-at}-1}{te^t} dt$ is convergent for any $a > 0$ and compute it. What about its uniform convergence?
3. Compute $\int \int_{x^2+y^2 \leq 9} \sqrt{x^2+y^2} dx dy$.
4. Find the volume of the space domain $\begin{cases} x^2 + y^2 \leq 8z \\ 0 \leq z \leq 2 \end{cases}$.

2. June, 2010

1. The graphic of $y = \sqrt{x} \sqrt[4]{x^2+1}$, $x \in [0, 1]$ rotates around Ox -axis. Find the volume of the resulting solid.
2. Prove that the integral $\int_0^\infty \frac{1}{(x^2+1)(x^2+4)} dx$ is convergent and then compute it.
3. Find the area of the plane surface bounded by the curves: $y = \sqrt{10}x$ and $y^2 = 10x$.
4. Compute $\iiint_{x^2+y^2+z^2 \leq 9, z \geq 0} z dx dy dz$. Draw this domain and supply with a mechanical interpretation the obtained result.

3. June, 2010

1. Prove that $I = \int_1^\infty \frac{\tan^{-1} x}{x^2} dx$ is convergent and compute it.
2. Compute the length of the curve $\Gamma : \begin{cases} x = t^2 \\ y = t^3 \end{cases}$, $t \in [0, 1]$.
3. Let $O(0, 0)$, $A(1, 1)$, $B(1, -1)$ and let the lamina OAB with the density function $f(x) = x$. Find its mass and the coordinates of its centre of mass.

4. Find the coordinates of the centre of mass for the total surface of the cone: $\begin{cases} x^2 + y^2 = 4z^2 \\ 0 \leq z \leq 2 \end{cases}$.

4. June, 2010

1. The curve $y = xe^{-x^3}$, $x \in [0, \infty)$ rotates around the Ox -axis. Find the volume of the obtained solid. First of all verify if this volume is finite.

2. Starting with the formula

$$\int_0^1 t^{x-1}(1-t)^{y-1} dt = \frac{\Gamma(x)\Gamma(y)}{\Gamma(x+y)}, x > 0, y > 0,$$

compute $J = \int_0^{\frac{\pi}{2}} \sin^6 x \cos^6 x dx$.

3. Let $A(2, 1)$ and $B(1, 0)$. The homogenous lamina OAB of density 2, rotates around Ox -axis. Find its moment of inertia w.r.t. Ox -axis.

4. Let $D : x^2 + y^2 + z^2 \leq 9, z \geq 0$. Compute $I = \iiint_D z^2 dx dy dz$.

5. September, 2010

1. Let $A(2, \sqrt{2})$, $B(1, 0)$ and $C(2, -\sqrt{2})$. Let γ be the arc of the parabola $y^2 = x$ which connect A and C . Let $[ABC]$ the polygonal line which passes through A, B and C . Compute the area bounded by γ and $[ABC]$.

2. Find the work of the field $\vec{F}(x, y) = xy \vec{j}$ along the polygonal arc $[OABO]$, with this orientation, where $A(1, 2)$ and $B(3, 0)$.

3. Compute the mass of the lamina $D : x^2 + y^2 \leq 9, x \geq 0, y \leq 0$, if the density function is $f(x, y) = |y|$.

4. Find the coordinates of the centre of mass for the solid bounded by the sphere $x^2 + y^2 + z^2 = 9$ and inside the cylinder $x^2 + y^2 = 4, z = 0$, if the density function is $f(x, y, z) = z$.

6. September, 2010

1. Prove that $I = \int_0^\infty \frac{1}{(\sqrt{x+1})^3} dx$ is convergent and then compute it.

2. Draw the domain $D : x^2 + y^2 \leq 4, x^2 + (y-1)^2 \geq 1$ and then find the centre of mass of D (the density function is considered to be $f = 1$).

3. If $a = \Gamma\left(\frac{2}{3}\right)$, compute $K = \int_0^\infty x^{10} e^{-x^3} dx$ as a function of a .

4. Find the volume of the domain $D : x^2 + y^2 \leq 2z, x^2 + y^2 + z^2 \leq 3$.

APPENDIX B

Basic antiderivatives

Prove all the following formulas (here $\int f(x)dx$ means a primitive of $f(x)$):

$$(0.1) \quad \int x^\alpha dx = \begin{cases} \frac{1}{\alpha+1}x^{\alpha+1}, & \text{if } \alpha \neq -1. \\ \ln x, & \text{if } \alpha = -1 \text{ and } x > 0 \\ \ln(-x), & \text{if } \alpha = -1 \text{ and } x < 0 \end{cases} .$$

$$(0.2) \quad \int a^x dx = \frac{a^x}{\ln a}, \text{ if } a > 0, a \neq 1.$$

$$(0.3) \quad \int \frac{1}{x^2 - a^2} = \frac{1}{2a} \ln \left| \frac{x-a}{x+a} \right|, a \neq 0, x \neq \pm a.$$

$$(0.4) \quad \int \frac{1}{x^2 + a^2} dx = \frac{1}{a} \tan^{-1} \frac{x}{a}, a \neq 0.$$

$$(0.5) \quad \int \frac{1}{\sqrt{x^2 + a^2}} dx = \ln \left| x + \sqrt{x^2 + a^2} \right|, a \neq 0.$$

$$(0.6) \quad \int \frac{1}{\sqrt{a^2 - x^2}} dx = \sin^{-1} \frac{x}{a}, a \neq 0, a^2 - x^2 > 0.$$

$$(0.7) \quad \int \sqrt{a^2 - x^2} dx = \frac{x}{2} \sqrt{a^2 - x^2} + \frac{a^2}{2} \sin^{-1} \frac{x}{a}, a \neq 0, a^2 - x^2 > 0.$$

$$(0.8) \quad \int \sqrt{x^2 \pm a^2} dx = \frac{x}{2} \sqrt{x^2 \pm a^2} \pm \frac{a^2}{2} \ln(x + \sqrt{x^2 \pm a^2}), a \neq 0.$$

$$(0.9) \quad \int \sin x dx = -\cos x.$$

$$(0.10) \quad \int \cos x dx = \sin x.$$

$$(0.11) \quad \int \frac{1}{\cos^2 x} dx = \tan x, x \neq (2k+1)\frac{\pi}{2}.$$

$$(0.12) \quad \int \frac{1}{\sin^2 x} dx = -\cot x, x \neq k\pi.$$

$$(0.13) \quad \int \tan x dx = -\ln |\cos x|, x \neq (2k+1)\frac{\pi}{2}.$$

$$(0.14) \quad \int \cot x dx = \ln |\sin x|, x \neq k\pi.$$

$$(0.15) \quad \int \frac{1}{\sin x} dx = \ln \left| \tan \frac{x}{2} \right|, x \neq k\pi.$$

$$(0.16) \quad \int \frac{1}{\cos x} dx = \ln \left| \tan \left(\frac{\pi}{4} - \frac{x}{2} \right) \right|, x \neq (2k+1)\frac{\pi}{2}.$$

$$(0.17) \quad \int \sinh x dx = \cosh x.$$

$$(0.18) \quad \int \cosh x dx = \sinh x.$$

$$(0.19) \quad \int \frac{1}{\cosh^2 x} dx = \tanh x = \frac{\sinh x}{\cosh x}.$$

$$(0.20) \quad \int \frac{1}{\sinh^2 x} dx = -\coth x = -\frac{\cosh x}{\sinh x}.$$

Index

- "closed" curve, 206
- "closed" surface, 209
- 1-dimensional deformation, 183
- 3-D plate, 315
- 3D-lamina, 315

- divergence, 343
- general domain, 273

- abelian integral, 27
- absolutely convergent, 119, 129
- abstract curve, 186
- algebraic function of one variable, 26
- almost everywhere, 61
- analytic, 362
- analytic function , 367
- analytic prolongation, 381
- annulus, 370
- approximation, 93
- area, 73
- area of a plane figure, 227
- automorphism, 14

- Bezout's theorem, 13
- binomial differential form, 32
- border, 351
- boundary, 351
- boundary of a subset, 70
- bounded domain, 362
- bounded function, 125
- bounded subset, 70

- Cauchy criterion, 155
- Cauchy criterion for improper integrals I, 118
- Cauchy criterion for improper integrals II, 128
- Cauchy criterion for limits, 112

- Cauchy criterion of uniform limit, 149
- Cauchy fundamental theorem, 366
- Cauchy inequalities, 378
- Cauchy integral formula, 377
- Cauchy-Riemann relations, 363
- central field, 204
- centre of mass, 317
- change of an elementary volume, 289
- change of variable formula, 9
- change of variables, 254
- change of variables formula, 257
- charge density, 343
- circulation, 198, 353
- closed differential form, 204, 218
- closure (topological), 70
- comparison test 1, 120, 130
- complementaries formula, 171
- complex convergence , 362
- complex curve, 362
- complex differentiability, 361
- complex function, 362
- complex functions, 361
- complex number field, 361
- complex path, 368
- conic surface, 327
- conical deformation, 313
- connected, 70
- connected domain, 362
- conservative field, 204
- continuity theorem, 151, 155
- continuity theorem for proper integrals with parameters, 140
- continuous, 362
- coprime polynomials, 16
- Coulomb law, 343
- curl F , 209, 353

- cylindrical coordinates, 299
- cylindrical deformation, 312
- Darboux criterion, 57, 229, 238, 276
- Darboux sums, 54
- decomposition into simple fractions, 20
- deformation, 183, 307
- density function, 51, 186, 227, 267, 315
- diameter, 274
- diffeomorphism, 254, 288
- differentiable, 362
- differential form, 4, 198
- differential form of order 2, 332
- differentiation theorem, 153
- Dirichlet's integral, 124, 162
- Dirichlet's test, 123, 133
- discontinuity points, 183
- distributions, 344
- divergence theorem, 341
- division, 51, 236, 274, 315, 328, 363
- domain, 70, 362
- double Darboux sums, 228
- double integral, 229
- double oriented, 328
- double Riemann sum, 228
- electric constant, 343
- electric field, 343
- element of area, 229, 316
- element of length, 188
- elementary domain, 273
- elementary figure, 70
- elementary figures, 227
- elementary functions, 168
- elementary subsets, 114
- elliptic integrals, 46
- epsilon-delta criterion, 110
- equivalent paths, 186
- essential point, 376
- essential singular point, 374
- Euclid's division algorithm, 11
- Euclidean division algorithm, 379
- Euler substitutions, 28
- Euler-Poisson integral, 164
- exact differential form, 204, 218
- Exam samples, 389
- explicitly described, 280
- F is integrable on the oriented surface (S), 329
- factorial formula, 171
- factoriality theorem, 15
- figure, 70
- flux of the vector $F(M)$ through the surface (S), at the point M, 329
- flux-divergence formula, 341
- flux-divergence theorem, 341
- Fourier expansion, 379
- Fresnel's, 124
- Fresnel's integrals, 165, 386
- Froullani's integrals, 159
- Fubini theorem, 155
- Fubini's theorem, 146
- fundamental theorem of algebra, 378
- Gabriel's trumpet, 115
- gain principle, 202
- gamma function, 168
- Gauss formula, 341, 350
- Gauss law in Physics, 343
- Gauss-Laplace distribution, 181
- general change of variables in triple integrals, 291
- general iterative formula I, 281
- general iterative formula II, 284
- generalized integrals of the first type, 115
- global flux, 329
- global productivity, 342
- gradient, 350
- gradient of temperature, 350
- greatest common divisor criterion, 16
- greatest common divisors for polynomials, 16
- Green formula, 246, 367
- Green theorem, 351
- heat, 350
- heat flow, 350
- imaginary part, 362
- improper integral of the second type, 126
- improper integral with a parameter, 154
- improper integrals of the first type, 115

- independent on path, 203
- inferior Darboux sum, 238, 275
- integrable, 274
- integrable on the arc ab , 364
- integral by parts, 10
- integral cosine, 143
- integral with parameters, 139
- integration theorem, 153
- interior point, 70
- interpolating function, 95
- interpolation polynomial, 96
- interpolation with parabolas, 100
- irreducible polynomial, 11
- irrotational field, 208
- iterative formula, 229
- iterative formulas for parallelepipeds, 270
- iterative general formula, 241
- Jordan's lemma, 383
- Koch's curve flake of snow, 190
- L-measure zero, 61
- Lagrange polynomial, 97
- lamina, 227
- Laplace equation, 351
- Laplace error function, 113
- Laurent series, 373
- Lebesgue criterion, 61
- Lebesgues measure zero, 61
- left limit, 107
- Leibniz formula, 155
- Leibniz' formula for proper integrals with parameters, 145
- Leibniz-Newton formula for line integrals, 206
- length of a curve, 89
- limit comparison test, 121, 131
- limit of a function, 107
- limit point, 107
- line integral of the first type, 188
- line integral of the second type, 198
- linear bar, 51
- Liouville theorem, 378
- loaded curve, 186
- Möbius surface, 325
- marking points, 51, 187, 236, 363
- mass center, 191
- mass of a bar, 51
- mass of a wire, 188
- mean formula, 278
- mean formula for line integrals, 190
- mean theorem, 317
- mean theorems
 - mean formulas, 65
- measurable, 71
- measure, 71
- n-connected Cauchy fundamental theorem, 369
- Newton area function, 3
- Newton-Leibniz formula, 67
- nodes, 96
- nonoverlapping, 215
- norm, 236, 274
- norm of a division, 51, 268, 315
- open ball, 70, 361
- orientable surface, 324
- orientated smooth curve, 199
- orientation function, 324
- orientation of an arc, 196
- oriented smooth curve, 206
- parabolic PDE, 351
- paraboloid, 319, 332
- parallelepiped, 70
- parallelepipedic domain, 268
- parameter, 183
- parametric equations of a surface, 307
- parametric path, 183
- parametric representation, 183
- parametric sheet, 307
- parametrisation, 183
- partial differential equation, 351
- partition, 274
- path, 183
- piecewise continuous, 227
- piecewise continuous function, 61, 267
- piecewise smooth, 183
- piecewise smooth curve, 362
- piecewise smooth surface, 267
- polar coordinates, 257
- pole, 374
- polygonal line, 70

- polynomial function, 10
- position vector, 183
- potential energy, 204
- potential field, 204
- potential function, 204
- potential theory, 344
- primitive
 - antiderivative, 3
- primitive function, 204
- principal value, 114, 127
- proper integral with one parameter, 140

- rate of flow, 350
- rational function of two variables, 26
- real function with complex values, 362
- real part, 362
- rectangles formula, 92
- rectifiable, 89
- reduction formula, 171
- reduction theorem, 301
- regular point, 376
- regular transformation, 288
- residue, 374
- residues formula, 370
- Riemann criterion, 57
- Riemann double sum, 148
- Riemann integrable, 52, 228, 237, 269, 274
- Riemann sphere, 372
- Riemann sum, 52, 188, 197, 237, 315, 329, 363
- right limit, 107

- segment (oriented), 70
- series test, 118
- series test 1, 136
- side limits, 107
- simple connected, 209, 366
- simple convergent, 154
- simple fractions, 19
- simple limit along a set of parameters, 149
- simple subdomain, 345
- simple w.r.t. Ox-axis, 213, 241
- simple w.r.t. Oy-axis, 214
- simple w.r.t. Oz-axis, 281
- Simpson formula, 101

- singular point for a function, 126
- singular points, 183, 374
- smooth, 183
- smooth deformation, 288, 323
- solid, 267
- space domain, 267
- specific heat, 350
- spherical coordinates, 295
- spherical deformation, 313
- starred, 218
- starred domain, 357
- Stokes formula, 353
- substitution, 32
- superior Darboux sum, 238, 276
- support curve, 183
- support of a lamina, 227
- surface, 307
- surface integral, 316
- surface integral of the second type , 329
- surface with two distinct faces, 324

- temperature, 350
- test p, 122
- test-q, 132
- tetrahedron, 334
- thermal conductivity, 350
- thin plate, 227
- totally closed, 341
- transition matrix, 322
- trapezoids formula, 95

- unbounded at a point, 126
- uniform limit along a set of parameters, 149
- uniformly continuous, 51
- uniformly convergent, 155
- upper half-plane, 383

- variation of a function, 51
- velocity of the heat flow, 350
- volume, 71

- weierstrass limit, 114
- Weierstrass test, 156
- well approximate, 330
- well approximated, 65, 365
- wire, 186
- work, 198, 353
- work of a field, 91

zero criterion, 116

Bibliography

- [BPC] E. M. Purcell, *Electricity and Magnetism, Berkeley Physics Course*, (Gauss law), Vol.2, Educational Devel Center, 1965.
- [Dem] B. Demidovich, *Problems in Mathematical Analysis*, Mir Publishers, Moscow, 1989.
- [DOG] C. Drăgușin, O. Olteanu, M. Gavrilă, *Analiză Matematică. Teorie și Aplicații*, Vol. I, II, III, Matrix Rom, Bucharest, 2010.
- [GG] G. Groza, *Analiză Numerică*, Matrix Rom, Bucharest, 2005.
- [Kra] M. Krasnov, A. Kiselef, G. Makarenko, E. Shikin, *Mathematical Analysis for Engineers*, Vol. I, II, Mir Publishers, Moscow, 1990.
- [Kr] E. Kreyszig, *Advanced Engineering Mathematics*, John Wiley & Sons Inc., 1999.
- [La] S. Lang, *Calculus of several variables*, Springer Verlag, 1996.
- [La1] S. Lang, *Algebra* (Revised Third Edition), Springer Verlag, 2002.
- [Nik] S. M. Nikolsky, *A course of Mathematical Analysis*, Vol. I, II, Mir Publishers, Moscow, 1981.
- [Pal] G. Păltineanu, *Analiză Matematică. Calcul Integral*, Editura AGIR, Bucharest, 2003.
- [Pis] N. Piskunov, *Differential and Integral Calculus*, Mir Publishers, Moscow, 1969.
- [Po] S. A. Popescu, *Mathematical Analysis I*, Conspress, Bucharest, 2009.
- [Po1] S. A. Popescu, *Algebră liniară și Aplicații*, Editura Universității, București, 1999.
- [Po2] S. A. Popescu, *Curs Practic de Algebră Liniară. Teorie și metode de rezolvare a problemelor de seminar*, UTCB, Bucharest, 1993.
- [Pop] E. Popescu, *Calcul Integral Multidimensional și Teoria câmpurilor*, Matrix Rom, Bucharest, 2007.
- [Pro] *** *Probleme de Analiză Matematică*, Catedra de Matematică și Informatică UTCB, Matrix Rom, Bucharest, 2002.
- [ST] A. Sveshnikov, A. Tikhonov, *The Theory of Functions of a Complex Variable*, Mir Publishers, 1978.